



Regal Series Infra-Red Cheesemelter

Item: _____

Quantity: _____

Project: _____

Approval: _____

Date: _____

Models:

- IRCMA-24 IRCMA-48 IRCMA-72
- IRCMA-36 IRCMA-60



Standard Features:

- Infrared burners
- Constant pilot for instant lighting
- Stainless steel top, front, and sides.
- Stainless steel cooking interior sides, back and bottom.
- Removable, chrome-plated wire rack
- Fiberglass insulated sides, bottom, and back
- 24" (610mm) to 72" (1829mm) widths available
- Range, wall and counter top models available; for range mount to U.S. Range Cuisine Series Heavy Duty gas range models.
- 3/4" N.P.T. top gas inlet connection.
- One year parts and labor

Optional Features:

- Interconnecting gas line between cheesemelter and range
- Wall mount kit

Specification:

Shall be U.S. Range Regal Series Cheesemelter. Unit shall be cuisine series range, wall or counter mounted. Unit to be available in widths from 24" (610mm) to 72" (1829mm) x 17 5/8" (448mm) deep x 18 3/4" (476mm) high. Finish is to be stainless steel front, sides and top. Removable chrome plated round rack. Shelves to be removable round stock chrome plated.



Regal Series Infra-Red Cheesemelter



Model #	Dimensions: In. (mm)			No. of Burners	Total BTU*	Weight Lb/Kg	Cu Ft
	Width (A)	Depth	Height				
IRCMA-24	24(610)	17-5/8(447)	18-3/4(476)	1	20,000	145/66	9
IRCMA-36	36(914)	17-5/8(447)	18-3/4(476)	1	30,000	185/84	13
IRCMA-48	48(1219)	17-5/8(447)	18-3/4(476)	2	40,000	230/105	17
IRCMA-60	60(1524)	17-5/8(447)	18-3/4(476)	2	50,000	265/120	21
IRCMA-72	72(1829)	17-5/8(447)	18-3/4(476)	3	60,000	300/136	25

*** Natural and Propane Gas**

Manifold Operating Pressure All Models			
Natural Gas		Propane	
"WC	Mbar	"WC	Mbar
5	12.5	10	25

Type of Construction Installation Minimum Clearance			
Combustible		Non-Combustible	
Rear	3" (76mm)	Rear	0"
Sides	6" (152mm)	Sides	0"

Counter installations base must be a non-combustible.

Many local codes exist and it is the responsibility of the owner and installer to comply with those codes.

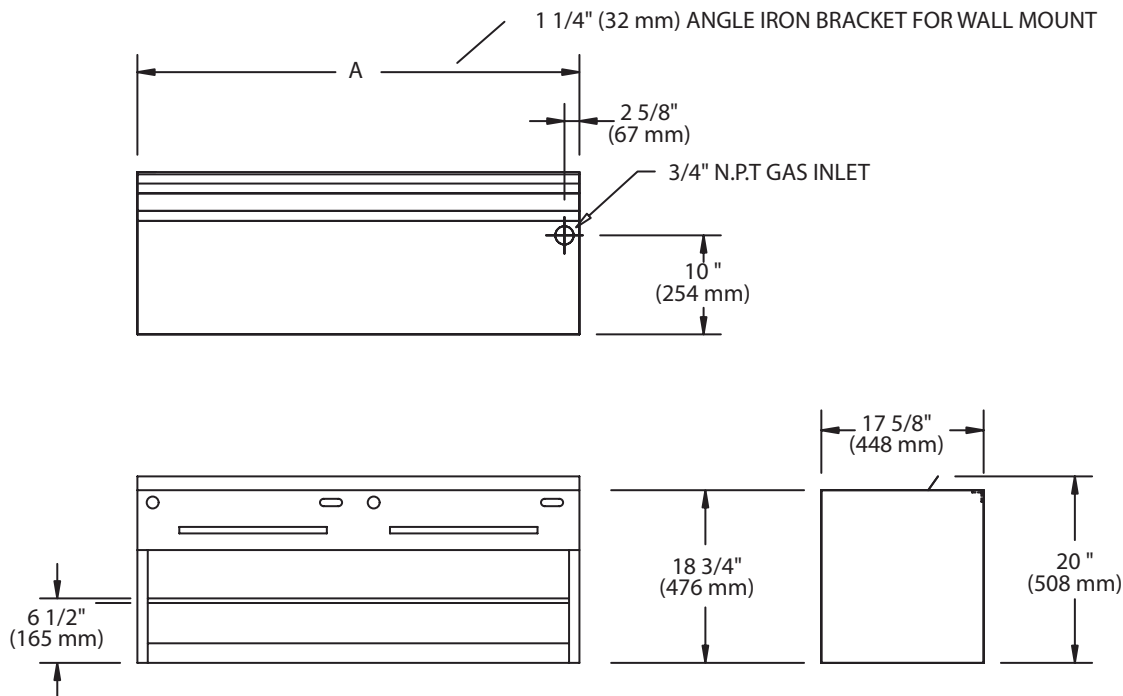

Garland/U.S. Range products are not approved or authorized for home or residential use, but are intended for commercial applications only. Garland / U.S. Range will not provide service, warranty, maintenance or support of any kind other than in commercial applications.

Form# IRCMA (10/11/11)