



# Sunfire Electric Convection Ovens

Item: \_\_\_\_\_  
 Quantity: \_\_\_\_\_  
 Project: \_\_\_\_\_  
 Approval: \_\_\_\_\_  
 Date: \_\_\_\_\_

Sunfire Electric Convection Ovens

Models:

ICO-E-10M

ICO-E-20M



Model ICO-E-10M

### Standard Features:

- Electromechanical thermostat with a temperature range of 200°F - 500°F (93°C - 260°C), and 60-minute timer
- Total of 11.0 kW loading per oven cavity
- 208 or 240 Volt, 3-Phase, (not convertible to single phase)
- Two-speed fan with 3/4 HP motor
- 60/40 dependent door design with double pane thermal window in both doors
- Interior lights
- Porcelain enameled oven interior w/covered corners
- Five (5) chrome plated oven racks on 11-position, removable rack guides
- Stainless steel front, sides, top, and legs
- Double-deck model available, (ICO-E-20M)

### Optional Features:

- Extra oven racks
- Swivel casters, set of four; two locking, (please specify single or double deck)

### Specifications:

Full-size, deep depth, electric convection oven with electro-mechanical thermostat, 60-minute timer and 2-speed fan. Designed as a general purpose oven for baking or roasting a variety of food products faster and at lower temperatures by circulating air throughout the oven cavity.



Note: Ovens supplied with casters must be installed with an approved restraining device.

Garland Commercial Ranges Ltd.  
 1177 Kamato Road,  
 Mississauga, Ontario  
 L4W 1X4 CANADA

General Inquires 1-905-624-0260  
 USA Sales, Parts and Service 1-800-424-2411  
 Canadian Sales 1-888-442-7526  
 Canada or USA Parts/Service 1-800-427-6668



Width	Depth	Height		Oven Interior Dimensions			Combustible Wall Clearance	
		ICO-E-10	ICO-E-20	Height	Depth	Width	Sides	Rear
40" (1016mm)	44-1/2" (1130mm)	60" (1524mm)	72" (1829mm)	20-1/2" (520mm)	28-1/2" (723mm)	29" (736mm)	6" (152mm)	6" (152mm)

NOTE: ICO-E-10 w/Optional Casters - Overall Height = 65-1/2" (1664mm)  
 ICO-E-20 w/Optional Casters - Overall Height = 71-1/2" (1816mm)

Model	Shipping	
	Lbs./Kg	Cube
ICO-E-10M	550/250	58.0
ICO-E-20M	1100/495	114.0

Model	Total kW Load	Nominal Amperes Per Line					
		208V / 3Ø*			240V / 3Ø*		
		X	Y	Z	X	Y	Z
ICO-E-10M	11.0	32	32	28	28	28	24

\* Not convertible to single-phase  
 Double Deck Models require individual power supply connections.

Model	Entry Clearances	
	Crated	Uncrated
ICO-E-10M	47"	32-1/2"
ICO-E-20M	(1194mm)	(826mm)

- These appliances are intended for commercial use by professionally trained personnel.
- It is the responsibility of the installer to ensure that installation complies with all national and local codes.

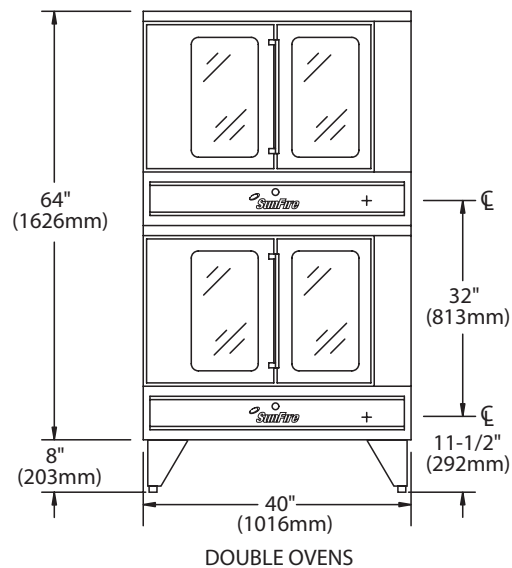
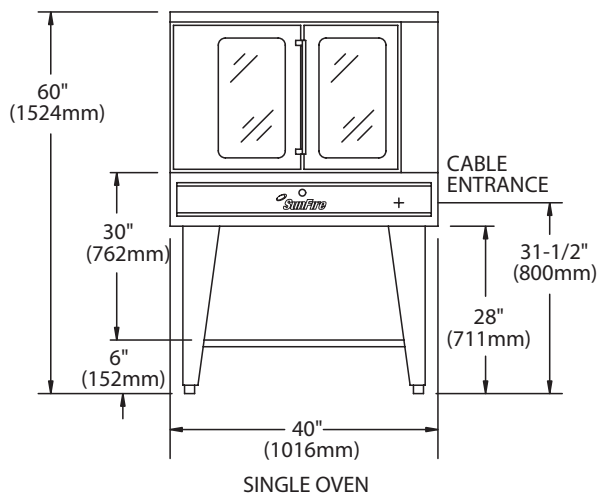
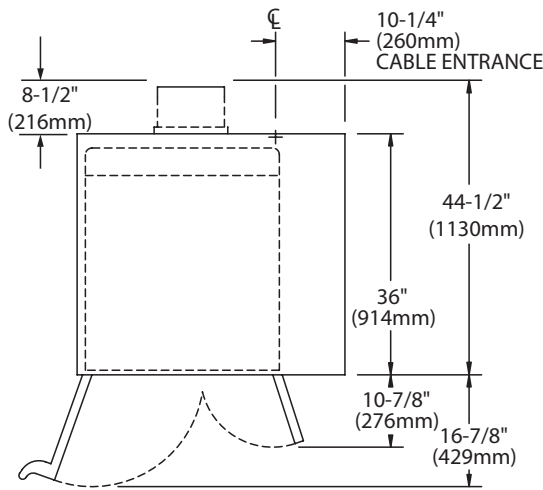

Form# SXICOE10 (08/17/11)