

NOTES: UNLESS OTHERWISE SPECIFIED

- INSTALLATION INSTRUCTION FOR HEARTH CLIPS
- 1 - PLACE A SCREWDRIVER, OR A SIMILAR PRYING DEVICE, BETWEEN THE COREPLATE AND HEARTHFRAME SUPPORT. PRY THE COREPLATE AWAY FROM THE HEARTHFRAME SUPPORT, (BEING CAREFUL NOT TO CHIP THE COREPLATE) THEN PLACE TWO SPACER CLIPS (PN.G03086-1-9) AS SHOWN ON THE DIAGRAM BELOW, BETWEEN THE COREPLATE AND THE HEARTHFRAME SUPPORT.
 - 2 - PLACE A SCREWDRIVER BETWEEN THE BACK OF THE RIGHT COREPLATE AND HEARTHFRAME SUPPORT. PRY THE COREPLATE FORWARD, AWAY FROM THE HEARTH SUPPORT AND PLACE A CLIP WITHIN THE SPACE.
 - 3 - REPEAT STEP 2 FOR THE LEFT COREPLATE.
 - 4 - REPEAT STEP 3 FOR THE CENTER COREPLATE FOR A 60" UNIT.

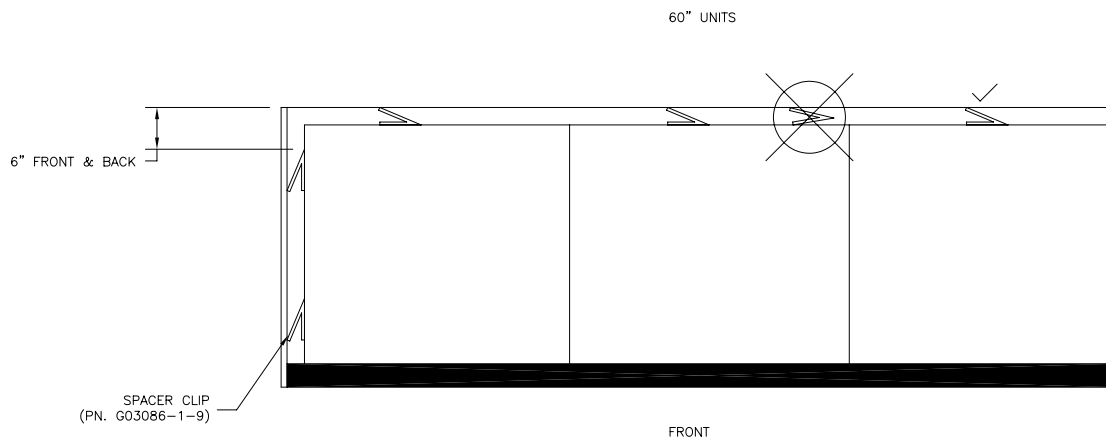
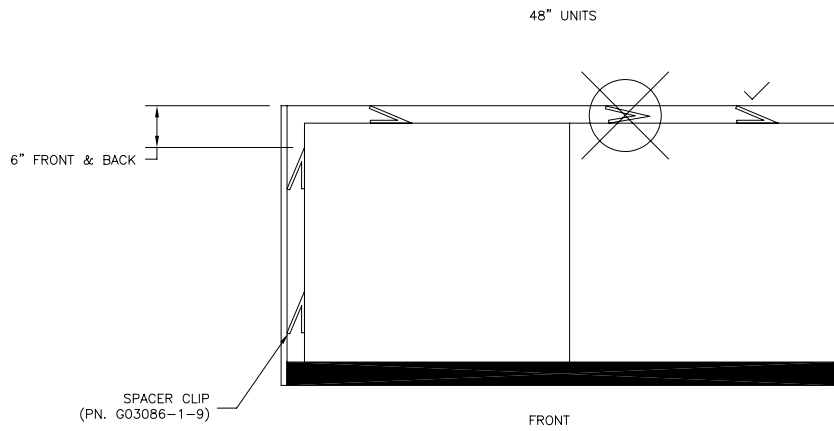

*** CAD PRODUCED DRAWING - DO NOT REVISE MANUALLY ***
 © 1999 GARLAND COMMERCIAL INDUSTRIES
 THESE DRAWINGS AND SPECIFICATIONS ARE THE PROPERTY OF GARLAND COMMERCIAL INDUSTRIES
 AND SHALL NOT BE COPIED OR REPRODUCED WITHOUT THEIR WRITTEN PERMISSION.

0	-	RELEASED ITEM/S 1	99-015	5/7/99	RJK	RK
REV	SYM	CHANGE DESCRIPTION	ECO	DATE	DR	APP

Garland A WELBILT Company	FREELAND PENNSYLVANIA 18224	SCALE FACTOR VARIES	SIZE C
-------------------------------------	-----------------------------------	------------------------	-----------

TOLERANCE (EXCEPT AS NOTED)					
FRACTIONAL ±1/64		DECIMAL ±.005		ANGULAR ±1'	
DESCRIPTION	DATE	DR.	BY	DR. CK.	APP.
HEARTH CLIP INSTRUCTIONS	5/7/99	RJK	RK	RK	RK
	MODEL(S) GAS PIZZA	FILE NAME 19174S01			

2			
1	1917401	HEARTH CLIP INSTRUCTIONS	0
ITEM	PART NUMBER	DESCRIPTION	REV