



INSTALLATION AND OPERATION MANUAL

GAS FRYER MODEL 35-280



FOR YOUR SAFETY:
DO NOT STORE OR USE GASOLINE
OR OTHER FLAMMABLE VAPORS OR
LIQUIDS IN THE VICINITY OF
THIS OR ANY OTHER
APPLIANCE

WARNING:
IMPROPER INSTALLATION, ADJUSTMENT,
ALTERATION, SERVICE OR MAINTENANCE
CAN CAUSE PROPERTY DAMAGE, INJURY,
OR DEATH. READ THE INSTALLATION,
OPERATING AND MAINTENANCE
INSTRUCTIONS THOROUGHLY
BEFORE INSTALLING OR
SERVICING THIS EQUIPMENT

PLEASE READ ALL SECTIONS OF THIS MANUAL
AND RETAIN FOR FUTURE REFERENCE.

THIS PRODUCT HAS BEEN CERTIFIED AS
COMMERCIAL COOKING EQUIPMENT AND
MUST BE INSTALLED BY PROFESSIONAL
PERSONNEL AS SPECIFIED.

IN THE COMMONWEALTH OF MASSACHUSETTS
THIS PRODUCT MUST BE INSTALLED BY A
LICENSED PLUMBER OR GAS FITTER. APPROVAL
NUMBER: G-1-07-05-28

For Your Safety:
Post in a prominent location, instructions to be
followed in the event the user smells gas. This
information shall be obtained by consulting
your local gas supplier.

Users are cautioned that maintenance and repairs must be performed by a Garland authorized service agent using genuine Garland replacement parts. Garland will have no obligation with respect to any product that has been improperly installed, adjusted, operated or not maintained in accordance with national and local codes or installation instructions provided with the product, or any product that has its serial number defaced, obliterated or removed, or which has been modified or repaired using unauthorized parts or by unauthorized service agents. For a list of authorized service agents, please refer to the Garland web site at <http://www.garland-group.com>. The information contained herein, (including design and parts specifications), may be superseded and is subject to change without notice.

GARLAND COMMERCIAL INDUSTRIES
185 East South Street
Freeland, Pennsylvania 18224
Phone: (570) 636-1000
Fax: (570) 636-3903

GARLAND COMMERCIAL RANGES, LTD.
1177 Kamato Road, Mississauga, Ontario L4W 1X4
CANADA
Phone: 905-624-0260
Fax: 905-624-5669

Enodis UK LTD.
Swallowfield Way, Hayes, Middlesex UB3 1DQ ENGLAND
Telephone: 081-561-0433
Fax: 081-848-0041

IMPORTANT INFORMATION

WARNING:

This product contains chemicals known to the state of california to cause cancer and/or birth defects or other reproductive harm. Installation and servicing of this product could expose you to airborne particles of glass wool/ceramic fibers. Inhalation of airborne particles of glass wool/ceramic fibers is known to the state of california to cause cancer. Operation of this product could expose you to carbon monoxide if not adjusted properly. Inhalation of carbon monoxide is known to the state of california to cause birth defects or other reproductive harm.

Keep appliance area free and clear of combustibles.

NOTE: Before leaving the factory, the fryer was tested with oil in the frypot; therefore, it is necessary to clean the frypot before adding frying compound. Rinse the frypot with clean water, then put some fryer cleaner on a damp cloth, full strength, and wipe the entire frypot clean. Rinse it thoroughly and wipe dry. The fryer is now ready for use. If the fryer does not have a stainless steel frypot and is not to be used immediately after cleaning, coat the entire frypot surface with shortening or cooking oil to prevent rusting.

TABLE OF CONTENTS

Contents

IMPORTANT INFORMATION.....	2
DIMENSIONS AND SPECIFICATIONS	4
INSTALLATION	5
Rating Plate.....	5
Pre-Installation Instructions	5
Casters	5
Legs.....	6
Clearances:	6
Gas Connections.....	6
Frypot.....	6
Ventilation and Air Supply.....	6
Radiation Shield and Flue Riser	7
OPERATION.....	8
Using the fryer for the first time	8
Lighting Instructions	8
Stand By.....	8
Complete Shut Down	8
Safety Concerns	8
Optimum Operation Tips.....	9
Suggestions for Quality Fried Food	9
CLEANING AND MAINTENANCE.....	10
Routine Care.....	10
Cleaning.....	11
Painted Finishes.....	11
Stainless Steel.....	11
Draining and Filtering Instructions	11
Maintenance	12
Preventive Maintenance	12
ADJUSTMENTS AND TROUBLE SHOOTING	13
Adjustments.....	13
Thermostat Calibration Instructions.....	13

DIMENSIONS AND SPECIFICATIONS

MODEL	# OF BURNERS	NATURAL		PROPANE	
		Orifice	Input	Orifice	Input
35-280	9	#51	110,000	#57	110,000

Operating Gas Pressure: Natural: 4.0" w/c, Propane: 9.0" w/c

Model 35-280

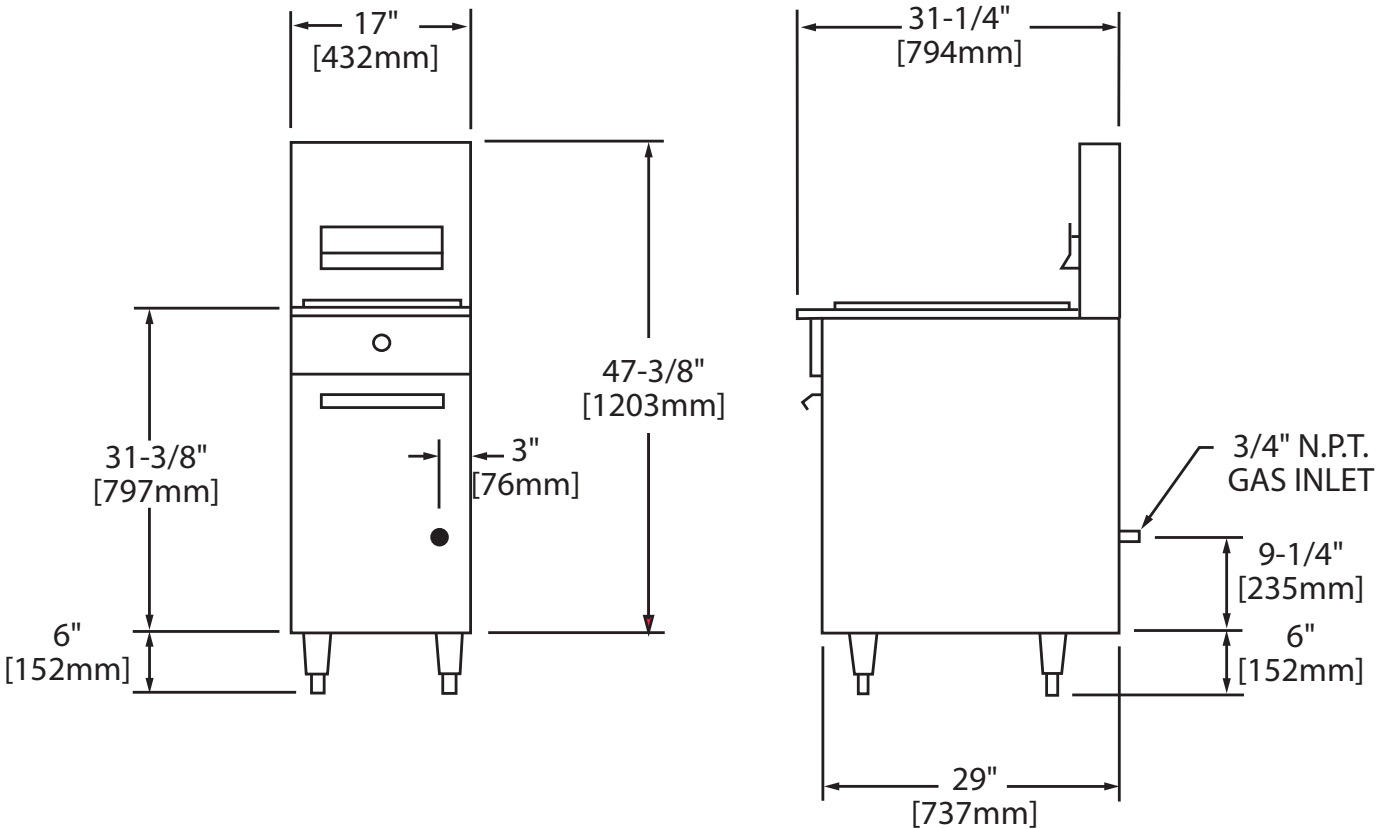

INSTALLATION

Rating Plate

When corresponding with the factory or your local authorized factory service center regarding service problems or replacement parts, be sure to refer to the particular unit by the correct model number (including the prefix and suffix letters and numbers) and the warranty serial number. The rating plate affixed to the unit contains this information.

We suggest installation, maintenance and repairs should be performed by your local authorized service agency listed in your information manual pamphlet.

In the event you have any questions concerning the installation, use, care or service of the product, write or call our Product Service Department.

This product has been certified as commercial cooking equipment and must be installed by professional personnel as specified.

Pre-Installation Instructions

Before assembly and connection check gas supply.

- A. The type of gas for which the unit is equipped is stamped on the data plate located on inner door panel. Connect a unit stamped "NAT" only to natural gas; connect those stamped "PRO" only to propane gas.
- B. If it is a new installation have the gas authorities check meter size and piping to assure that the unit is supplied with sufficient amount of gas pressure required to operate the UNIT.
- C. If it is additional or replacement equipment have gas authorities check pressure to make certain that existing meter and piping will supply fuel to the unit with not more than 1/2" water column pressure drop.

NOTE: When checking gas pressure be sure that all other equipment on the same gas line is on.

A pressure regulator is supplied as standard equipment with GARLAND Restaurant Series Gas Fryers. The pressure regulator is "built-in" to the fryer, (the regulator is part of the combination safety valve). Installation must conform with the national Fuel Gas code ANSI Z223.1-1988 or latest edition NFPA No. 54 – Latest Edition and National Electrical Code ANSI/NFPA 70-1990 or latest edition and /or local code to assure safe and efficient operation.

NOTE: The appliance and its individual shut-off valve (not supplied by manufacturer) must be disconnected from the gas supply piping system during any pressure testing of that system at pressures in excess of 1/2 PSIG (3.45 kP2). The appliance must be isolated from the gas supply piping system by closing its individual manual shut-off (not supplied by manufacturer) during any testing of the gas supply piping system at test pressures equal to or less than 1/2 PSIG 3.45 kP2).

NOTE: In Canada, the installation shall be in accordance with CAN/CGA-B149.1 NATURAL GAS INSTALLATION CODE or CAN/CGA-B149.2 PROPANE GAS INSTALLATION CODE and local codes where applicable.

NOTE: Adequate clearance must be provided for servicing and proper operation.

NOTE: Garland/U.S. Range products are not approved or authorized for home or residential use, but are intended for commercial applications only. Garland / U.S. Range will not provide service, warranty, maintenance or support of any kind other than in commercial applications.

The importance of proper installation of commercial gas cooking equipment cannot be over stressed. Proper performance of the equipment is dependent, in great part, on the compliance of the installation with the manufacturer's specifications. In addition, compliance with the National Fuel Gas code ANSI Z223.1-1988/NFPA and/or Local code is required to assure safe and efficient operation.

Appliances shall be installed in a location in which the facilities for ventilation permit satisfactory combustion of gas and proper venting. Appliances shall be located so as not to interfere with proper circulation of air within the confined space. When buildings are so tight that normal infiltration does not provide the necessary air, outside air shall be introduced.

Casters

- A. The installation shall be made with a connector that complies with the Standard for Connectors for Movable Gas Appliances, ANSI Z21.69 / CSA 6.16, and a quick-disconnect device that complies with the Standard for Quick-Disconnect Devices for Use With Gas Fuel, ANSI Z21.41 / CSA 6.9..

INSTALLATION Continued

- B. The front casters of the unit are equipped with brakes to limit the movement of the fryer without depending on the connector and any quick disconnect device or its associated piping to limit the appliance movement.
- C. Please be aware, required restraint is attached to a bracket on the fryer (connections point is located on the left rear caster of the fryer), and if disconnection of the restraint is necessary, be sure to reconnect the restraint after the fryer has been returned to its originally installed position.

NOTE: When installed, the fryer must be restrained to prevent tipping in order to avoid the splashing of hot liquid. The means of restraint may be the manner of installation, such as connection to a battery of appliances or installing the fryer in an alcove, or by separate means, such as adequate ties.

Legs

Raise front of the unit and block. Do not lay unit on its back. Position leg insert into leg retainer opening and tap up until it seats at collar flange. Repeat at rear of unit making sure all four legs are adjusted to same height. legs can be adjusted to overcome an uneven floor.

Clearances:

From Combustible material 6" sides and rear. A clearance of 0.0" to noncombustible construction as sides & rear is acceptable. The fryer is suitable for installation on combustible floors.

Gas Connections

The size of the gas line is very important. If the line is too small, the gas pressure at the burner manifold will be low. This will cause slow recovery, delayed ignition, and pilot outage. Refer to the Gas Line Sizing Chart in the National Fuel code book.

Before connecting new pipe to your GARLAND Fryer, the pipe must be thoroughly blown out to dispose of all foreign particles. If these foreign particles get into the burner and controls they will cause improper and sometimes dangerous operation.

When using thread compound, use it sparingly and only on male threads. Use compound that is impervious to the action of Propane gasses. Do not put any on the first two threads. This will prevent fouling the controls and clogging the pilot and main burner orifices.

Make sure the installer checks all plumbing with a soap solution for leaks. DO NOT USE A FLAME, MATCHES, CANDLES, or other ignition source in checking for leaks.

Frypot

Before leaving the factory, the fryer was tested, and the thermostat, was calibrated, with oil in the frypot; therefore, it is necessary to clean the frypot before adding frying compound. Rinse the frypot with clean water, then put some fryer cleaner on a damp cloth, full strength, and wipe the entire frypot clean. Rinse it thoroughly and wipe dry. The fryer is now ready for use. If the fryer does not have a stainless steel frypot and is not to be used immediately after cleaning, coat the entire frypot surface with shortening or cooking oil to prevent rusting.

Ventilation and Air Supply

One of the most important considerations is ventilation. The fryer must be installed so that products of combustion are removed efficiently, but so that the kitchen ventilation system does not produce drafts that interfere with proper burner operation. The fryer flue opening must NOT be placed close to the intake of the exhaust fan.

The fryer must never have its flue extended in a "chimney" fashion. This changes the combustion characteristics of the fryer. This will cause the fryer to be slow to recover, frequently cause delayed ignition, and sometimes cause pilot outage.

The ideal method of ventilating a fryer is the use of a properly designed canopy which should extend six inches (6") beyond all sides of the appliance and six feet (6') six inches (6") from the floor.

Many operators do not realize that the finest ventilation system will break down when it is not maintained properly. The duct system, the hood, and the filter bank must be cleaned on a regular basis and kept free of grease.

Adequate distances must be maintained from the flue outlet of the fryer to the lower edge of the filter bank. Filters should never be installed in the horizontal position. They should be installed at an angle of 45 degrees, and a drip tray should be located beneath the lowest edge of the filter. NFPA Standard No. 96 states that "A Minimum distance of 18" should be maintained between the flue outlet and the lower edge of the grease filter." We recommend that the "minimum distance be 24" from the flue outlet to the bottom edge of the filter when the appliance consumes more than 120,000 B.T.U. per hour.

INSTALLATION Continued

A strong exhaust fan will create a vacuum in the room, for an exhaust system vent to work properly, replacement air must enter the room in which the vent is located.

All gas burners and pilots need sufficient air to operate and large objects should not be placed in front of this fryer which would obstruct the air flow through the front. A minimum of 24" should be provided at the front of the unit for servicing and proper operation. Air for combustion enters the unit below the cabinet at the base. Do not place anything around the base or under the fryer.

CAUTION: GARLAND Fryers cannot be installed on a masonry base or without proper clearance from floor. Primary air is supplied to the "jet - type" burner from the front and mainly from the bottom of the fryer.

If installed on a masonry base or directly on floor without the use of the factory supplied 6" legs or casters, improper combustion will occur.

Radiation Shield and Flue Riser

The radiation shield must be in place when fryer is installed in other than fire resistive locations.

IMPORTANT: The flue riser must be installed within the back guard. This rectangular riser fits over the collar of the flue collector box inside the fryer. Place the flue riser upright through opening in the back top and slide over collar. (See Figure 2.)

METHOD OF ATTACHING RADIATION SHIELD TO BACKGUARD OR HIGH SHELF

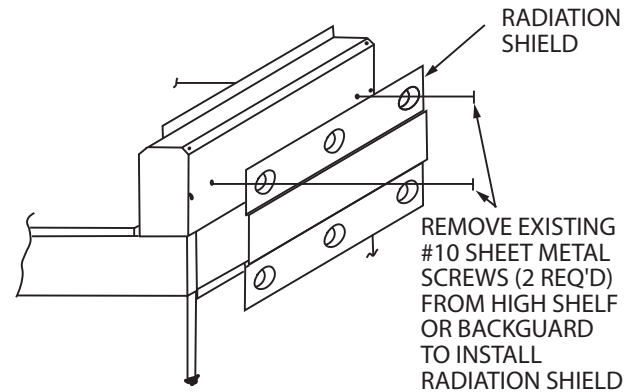

FIGURE 1

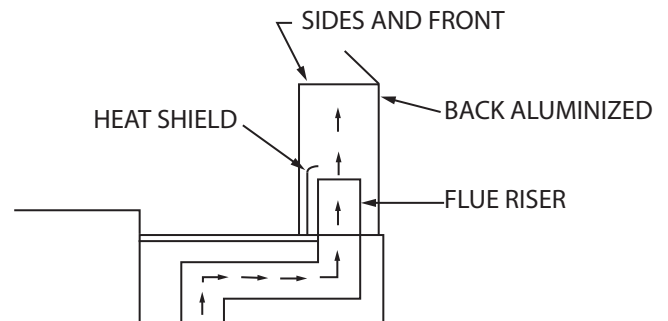

FIGURE 2

OPERATION

Using the fryer for the first time

Before lighting the pilot, fill the frypot with frying compound. Then light the pilot according to the instructions inside the fryer compartment on the inner panel. If you are using a cooking oil, you may now turn the main burner on by turning the knob on the automatic gas valve. If you use a hydrogenated (solid) frying compound, it is wise to melt it in a stock pot on the range before putting it in the fryer. If this is not done, pack the frypot with the compound and turn the main burner on for a few seconds and turn it off for a few. See the lighting and shut-down instructions for "How to turn on the main burner once the pilot is lighted."

Intervals of about three seconds on and ten seconds off are about right. Keep doing this until the shortening is melted. If any smoke is seen during this process, you are heating too fast and scorching the shortening, thus cutting down its useful life and possibly damaging the frypot. Shortening level must cover the thermostat bulbs when fryer is in operation.

After turning the main burner on, set the thermostat at 325° to check calibration of the thermostat. Let the burner cycle at least four times and suspend a deep fat fryer thermometer in the middle of the frypot about 3" deep. When the burner just comes on after the fourth cycle, the reading on the thermostat should agree with the thermostat setting. If not, calibrate the thermostat according to the instructions in the Cleaning and Maintenance Section of this manual.

Lighting Instructions

For specific models see "Lighting Instructions" on the inside of fryer compartment.

(Frypot must be filled before lighting).

1. Turn Thermostat knob to frying temperature. The thermostat knob is located inside the compartment in the front of the frypot.
2. Open the fryer door and turn the combination safety valve knob to the PILOT position.
3. Push the knob in, light the pilot and continue to hold knob in for about sixty seconds after the flame has been lit.
4. Turn valve knob counterclockwise to ON.
5. Main burners will now light and will be controlled automatically by the thermostat.

Note: Fryer cannot be shut off at the thermostat. Thermostat used only to control temperatures.

Stand By

1. Turn fryer gas valve knob to "PILOT" POSITION
2. Put frypot cover in place.

Complete Shut Down

Turn gas valve knob clockwise to pilot position, DEPRESS knob, slightly clockwise, release knob and continue turning clockwise to OFF.

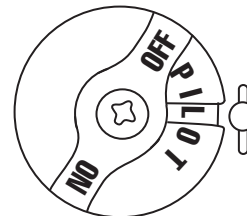

AUTOMATIC VALVE KNOB
PILOT POSITION

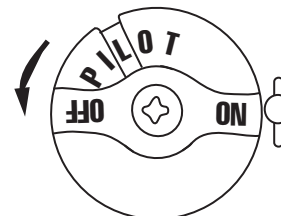

AUTOMATIC VALVE KNOB
ON POSITION

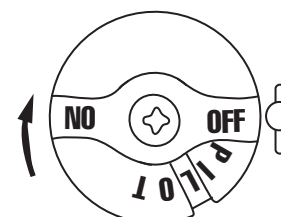

AUTOMATIC VALVE KNOB
OFF POSITION

Safety Concerns

WARNING: The operator should be aware of the HAZARDOUS NATURE, inadvertent splashing and spilling etc., and RESULTANT CONSEQUENCES, personal burns, fires, slipping on spilled liquid etc., when moving the fryer with liquid in the vessel. If the fryer is to be moved, it is recommended that the liquid in the vessel be cooled to room temperature and removed from the vessel.

OPERATION Continued

To assure you of maximum protection and performance your GARLAND Fryer is equipped with the best and most reliable controls and safety devices available. The operation thermostat will regulate frying compound temperatures to close tolerances in a range between 250° and 375°.

If for any reason the pilot should be extinguished the combination safety valve will close off the gas flow to the main burners and pilot burner. As an additional safety feature this valve prevents gas from flowing to the main burners when the pilot is being ignited.

On all units, due to the high rate of heating, a high limit control device is provided as standard equipment. If for any reason the frying compound temperature exceed the maximum dial temperature the entire fryer will turn OFF at 450°F. If this should occur, have qualified service technician check the system. FOR NO REASON SHOULD THIS HIGH LIMIT DEVICE BE BY-PASSED.

Optimum Operation Tips

One of the most important considerations in the profitable use of a fryer is the choice of the frying compound used. A better frying compound will actually cost you less, because it lasts longer than the lower grades and produce fried foods with superior taste and appearance. There are numerous high-grade products available and you are strongly urged to use them.

For maximum frying compound life, good operators find they do best by frying at the lowest temperature that will give a high-quality product. Thus, with a super-fast fryer, such as your GARLAND, you do not have to fry potatoes at 375°F or 400°F, you fry at 325°F. A little experimenting will determine just the right temperatures for your menu items.

The worst enemies of frying compound are light, heat, air and salt. Thus, its life can materially be lengthened by keeping the fryer covered when not in use, frying at the lowest temperatures, and by reducing the temperatures during stand-by periods.

A common habit which is harmful to frying compounds is that of salting foods in baskets over the frypot. Also, if food is fried ahead and stored over the frypot to keep hot, as is often done, it will rapidly lose its crispness and will taste greasy.

A common error in frying is to overload the baskets under the mistaken impression that this will increase the production of the fryer. For any given fryer, and any given food product being fried there is a certain load which will produce the maximum amount of food per hour. For best results, we recommend the baskets be filled between 1/2 and 2/3 full. If the baskets are loaded beyond this, the total hourly production rate will decrease.

To give you a starting point, the following chart suggests the temperatures at which most operators fry certain foods:

FRYING CHART		
Product	Temperature	Time
French Fried Potatoes		
Raw-to-done	350	5-7 Min
Blanching	325	4 Min
Browning	350	2 Min
French Fried Onion Rings	360	2-3 Min
Seafood		
Shrimp	360	2-3 Min
Oysters	350	1-4 Min
Scallops	250	3-5 Min
Fillets	350	3-4 Min
Clams	350-360	1-3 Min
Chicken		
Small Pieces	350	6-10 Min
Large Pieces	350-360	8-11 Min
Cutlets, Chops (1" thick)	325	5-7 Min
Fritters		
Fruit	350	3-5 Min
Vegetables (asparagus, cauliflower, corn, eggplant, tomato)	350	5-8 Min

Suggestions for Quality Fried Food

- Fresh, uncontaminated fryer compound produce better fried products.

OPERATION Continued

- Taste the frying compound once a day. Your patrons do, when they eat the product.
- Filter the frying compound daily. Merely straining the shortening is inadequate. You may choose the GARLAND Filter Quick filtering system. This system is designed to match-up to your GARLAND Fryer. Or, you may choose to use a filter and filter cone.
- Drain or dry foods before frying. Excess moisture and water breaks down frying compound.
- Do not salt or otherwise season food over the fryer. This practice contaminates the frying compound and accelerates its deterioration.
- Do not shake breaded items over the fryer.
- Keep the frypot covered when not in use. This will prevent air from oxidizing the frying compound and will keep impurities out.
- Do not overheat the frying compound. Follow the temperature recommended in tested recipes. The company which provides your frying compound can provide tested recipes and techniques for use with their shortening.
- Watch for signs of compound breakdown. An unusual darkening of the compound or smoking are the first signs of breakdown. Foaming, objectionable change in flavor of the product and gumming also indicate a breakdown of the frying compound.
- Set the thermostat at 200°F or below, when not frying.
- Darkened frying compound and incorrect batter or breading can cause a fried product to appear to be done. Use a tested recipe or obtain batter or breading specially prepared for today's frying techniques.

CLEANING AND MAINTENANCE

Routine Care

NEVER operate the burner with an empty frypot. It only takes a few minutes to completely ruin a frypot this way, and the frypot warranty is void if this is done.

The frying compound should be filtered at least once a day. If a heavy volume of breaded food is fried, it may be necessary to filter two or more times a day. This will increase the life of the frying compound and produce better-tasting food.

GARLAND filter cones are ideal for this and are inexpensive and readily obtainable from your dealer or parts distributor.

Establish a regular cleaning schedule. Any spills should be wiped off immediately.

The fryer should be cleaned daily, and this operation can be combined with filtering the frying compound. After the fryer is drained, wipe the inside with cloth saturated in a commercial fryer/griddle cleaner, then rinse thoroughly. Wipe dry and put the filtered compound back in the frypot. The frypot should be boiled out once a week with a commercial fryer/griddle cleaner according to direction on the bottle. Each day wipe down the controls and all inside the door with a damp cloth. Remove the basket hanger and clean at least once a week. This way your fryer will stay clean and new looking much longer. Be sure that the grease cover for the automatic gas valve is kept in place

CLEANING AND MAINTENANCE Continued

Cleaning

Painted Finishes

Establish a regular cleaning schedule. Any spills should be wiped off immediately.

The fryer should be permitted to cool down before cleaning exterior surfaces.

1. Wipe exposed, cleanable surface when cool with a mild detergent and hot water. Stubborn residue spots may be removed with a light weight non metallic scouring pad. Dry thoroughly with a clean cloth.
2. Stainless steel should be cleaned using a mild detergent, a soft cloth and hot water. If necessary to use a nonmetallic scouring pad, always rub in the direction of the grain in the metal to prevent scratching. Use a water based stainless cleaner (commercially available), if you want a high shine.

Stainless Steel

For routine cleaning just wash with a hot water and detergent solution. Wash just a small area at a time or the water will evaporate leaving the chemicals behind causing streaking. Rinse the washed area with a clean sponge dipped in a sanitizing solution and wipe dry with a soft clean cloth before it can dry. Use a paste (of water and a mild scouring powder) if you have to, but never rub against the grain. All stainless steel has been polished in one direction. Rub with the polish lines to preserve the original finish. Then thoroughly rinse as before. To prevent fingerprints there are several stainless steel polishes on the market that leave an oily or waxy film. Do not use on surfaces that will be in contact with food.

Stainless steel may discolor if overheated. These stains can usually be removed by vigorous rubbing with a scouring powder paste. Use only stainless steel, wood or plastic tools if necessary to scrape off heavy deposits of grease and oil. Do not use ordinary steel scrapers or knives as particles of the iron may become imbedded and rust. **STEEL WOOL SHOULD NEVER BE USED.** Either a typical bleach solution or hot water can be used to sanitize stainless steel without harm.

Draining and Filtering Instructions

The draining and filtering of fryer compound must be accomplished with care to avoid the possibility of a burn resulting from careless handling.

Filtering: Turn fryer off. If you are using a filter other than the GARLAND Filter Quick, consult the filtering manufacturers' operation instructions for recommended filtering procedure. Instructions for use of the filter Quick are included in the Owners Manual shipped with your filter Quick unit.

The following is a recommended procedure to drain and filter your compound when no filter machine is available:

1. Screw the drain pipe provided with your fryer into the drain valve. Assure that you have firmly attached the drain pipe and that the curved end portion is pointing out.
2. Position the stock pot or other container under the drain pipe. The stock pot or other container must be of sufficient design to withstand the heat generated by the hot compound and must also be able to hold liquids. It is recommended that where no filter machine is available, the filter cone holder and filter cones be used. Be sure the filter cone holder is resting securely on the stock pot or other container.
3. Open the drain valve slowly to avoid splattering. However, since splattering may occur anyway, extreme caution should always be employed.
4. If the valve becomes clogged with food particles you may wish to use a poker-like tool. The tool must be used from the inside of the frypot only and caution should be employed that the tool is gripped by the user as far as possible from the hot fryer compound in the frypot. Do not hammer on the drain valve as damage to the ball inside the valve will cause it to leak. **NEVER** use this tool or any other tool to unclog the valve from the front of the valve. If the clog comes loose, hot compound could pour out rapidly so beware of splattering in this event.
5. We recommend that the drained compound be allowed to cool to 100°F or lower before transporting the stock pot or other container, removing the drainpipe, or removing the filter cone holder and filter cone

CLEANING AND MAINTENANCE Continued

Maintenance

Your GARLAND equipment is ruggedly constructed and is designed, with normal care, to give you long and lasting service. It is, of course, desirable to keep your equipment in the best possible condition. As the equipment is used, whether in light or heavy duty service, it should be cleaned often and a regular cleaning schedule should be established on a daily, week and/or monthly basis, depending upon severity of use.

Preventive Maintenance

Your GARLAND equipment is ruggedly constructed and is designed, with normal care, to give you long and lasting service. It is, of course, desirable to keep your equipment in the best possible condition. As the equipment is used, whether in light or heavy duty service, it should be cleaned often and a regular cleaning schedule should be established on a daily, week and/or monthly basis, depending upon severity of use.

Preventive Maintenance

In order to keep the unit operation at top efficiency, it is advisable to perform preventive maintenance regularly. The frequency of this maintenance will depend on how hard the unit is used, and you should discuss this with your nearest GARLAND Authorized Service Agent.

Preventive maintenance should cover at least the following:

1. Check pilot flame for correct length.
2. Check main burner flames for good ignition and proper burner adjustment.
3. Check thermostat calibration.
4. Check thermopile output.
5. This fryer needs no lubrication.

ADJUSTMENTS AND TROUBLE SHOOTING

Adjustments

The burner used on your GARLAND Fryer is a patented design which does not require primary air, so no primary air adjustment is possible. When the proper gas is being used, at the proper pressure, and the ceramic targets are adjusted properly, combustion will begin about even with the bottom of the ceramic. The sound that is characteristic is a low roar, similar to a blowtorch.

The correct type of gas and BTU content for which the fryer was equipped at the factory is noted on the nameplate, and this gas must be used.

NEVER THROTTLE DOWN THE INCOMING GAS IN AN EFFORT TO MAKE THE FLAME BURN DIRECTLY ON THE ORIFICE.

A piece of mechanical equipment which is used as hard as a deep fat fryer is going to require service as the fryer gets older; therefore, the following chart outlines problems that are most likely to occur and what to do to correct them.

There are several possible sources of trouble in connection with the operating thermostat. Usually the trouble will be noticed by either the thermostat not causing the gas valve to open, or by causing it to open at the wrong temperature. It opens the gas valve at the wrong temperature, it is said to be out of calibration. If all the other parts of the appliance are operation as they should, the following chart will help locate the source of trouble and

Possible Causes	Remedy
1 Thermostat does not call for heat (does not open gas valve at all). <ul style="list-style-type: none"> a. Lead wires damaged. b. Set too low. c. Out of calibration d. Thermostat defective 	1 See Below: <ul style="list-style-type: none"> a. Repair or replace wires on thermostat. b. Raise setting. c. Re-calibrate d. Replace
2. Thermostat does not control set point <ul style="list-style-type: none"> a. Out of calibration. b. Contaminated or burned contacts c. Knob of thermostat loose on shaft 	2 See Below: <ul style="list-style-type: none"> a. Re-calibrate b. Replace thermostat c. Calibrate thermostat and tighten set screws.

Thermostat Calibration Instructions

To calibrate the Fenwal Thermostat, fill the frypot to the FULL mark with frying compound and turn the burner on. Insert a thermometer in the center of the frypot with the bulb about two inches below the surface. Allow the burner to cycle about four times, the thermometer reading should be within 5° of the thermostat knob setting. If this does not agree with the pointer of the thermostat knob.

1. Loosen the two set screws on the thermostat knob,

2. Set the pointer at the temperature indicated on the thermometer,
3. Tighten the set screws firmly.
4. Be sure the black surface of the knob is spaced away from the dial plate at least the thickness of a dime.

NOTE: Do not turn adjusting shaft more than two turns in either direction or permanent damage can result. This action may void the standard warranty.

ADJUSTMENTS AND TROUBLE SHOOTING Continued

The Fenwal Thermostat is an electric switch with contacts that open on a temperature rise. It will respond to temperature changes of approximately 1° when the fryer is idling with no food being fried.

Turning the adjusting shaft counter-clockwise increases the temperature at which time the contacts will open. Some of the most common problems occur in connection with the pilot generator. These usually show as poor ignition of the main burner or frequent pilot outage.

At right is a diagram of how the Fenwal thermostat and Hi-Limit controls are wired to the safety system.

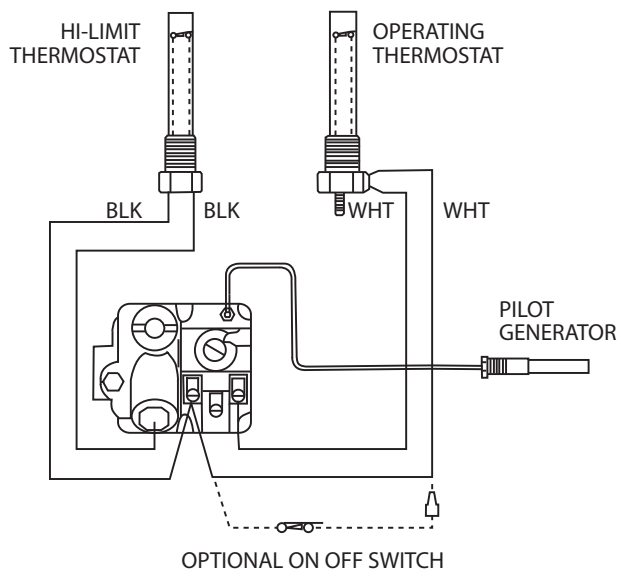

 **Garland**[®]