



# Master Series Heavy Duty Gas Fryer

Item: MST35SS

Quantity: \_\_\_\_\_

Project: \_\_\_\_\_

Approval: \_\_\_\_\_

Date: \_\_\_\_\_

Master Series Heavy Duty Gas Fryer

Model:

MST35SS

17" Gas Fryer



Model MST35SS, With Optional 17" Backguard & Casters

### Standard Features:

- Stainless steel front, front rail, and sides.
- Infra-red, jet-type burner, rated 110,000BTU/Hr., (32.23kW/Hr.)
- Piezo spark ignition with constant burning, 100% safety pilot
- Built-in pressure regulator
- 35lb., (16kg), capacity stainless steel frypot
- Twin chrome wire baskets
- 6" (152mm), chrome steel adjustable legs

### Optional Features:

- Stainless steel common front rail up to 68" (1728mm), wide, (2 or more units in a battery)
- Stainless steel main back
- Additional fry baskets

- Large single fry basket
- Stainless steel frypot cover
- Stainless steel fish plate
- Rear gas connection, 3/4" or 1-1/4" NPT
- Manifold end cap(s) and cover(s), (no charge)
- Swivel casters, (4), with front brakes
- Polyurethane, non-marking swivel casters, (4), with front brakes
- 6" (152mm), stainless steel adjustable legs
- Stainless steel backguard: 10" (354mm), 17" (432mm) or 33" (838mm) high
- 17" (432mm) wide frymate dump station, storage base, stainless steel pans with drain Chrome plated wire rack with handles, model M14FD
- Heat lamp for dump station

### Specifications:

Heavy-duty, range-match gas fryer, model MST35SS. 110,000 BTU/Hr., (32.23kW), infra-red jet-type burner. 35lb., (16kg), capacity stainless steel fry pot. 17" (432mm), wide x 38" (965mm), deep, including 8-1/4" (210mm) deep. Stainless steel front, front rail and, sides.



NOTE: Fryers supplied with casters must be installed with an approved restraining device.



TOTAL INPUT	MANIFOLD OPERATING PRESSURE		CLEARANCES				SHIPPING	
			INSTALLATION		ENTRY		Cu Ft	Weight
	NAT	PRO	Sides	Rear	Crated	Uncrated		
110,000 BTU/Hr (32.23kW/Hr)	4.0" WC (10mbar)	9.0" WC (22mbar)	6" (152mm)	6" (152mm)	29-1/4" (746mm)	17-1/4" (618mm)	26	220lb. (100kg)

Gas input ratings shown here are for installations up to 2,000 feet (610mm) above sea level.  
Input must be derated for high altitude installations.

FRYING CAPACITY (per hour)			
FRENCH FRIES		FISH	BREADED CHICKEN
Raw to Done	Blanched to Done	3oz. (84g), Battered	Raw to Done
60lb. (27kg)	80lb. (36kg)	60lb. (27kg)	28lb. (13kg)

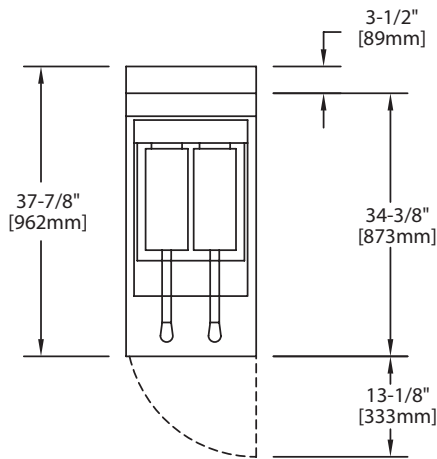

DIMENSIONS & SPECIFICATIONS	
Width	17" (432mm)
Depth	38" (965mm)
Height (w/ NSF Legs)	36-3/8" (924mm)
Height (w/o NSF Legs)	30-3/8" (772mm)

Garland/U.S. Range products are not approved or authorized for home or residential use, but are intended for commercial applications only. Garland / U.S. Range will not provide service, warranty, maintenance or support of any kind other than in commercial applications

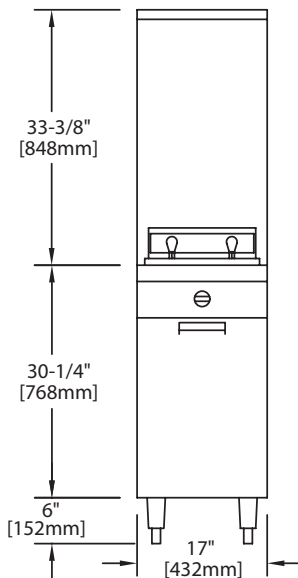

**NOTE:**  
Double-Deck High Shelf, (DDHS), is not recommended for use over fryer.

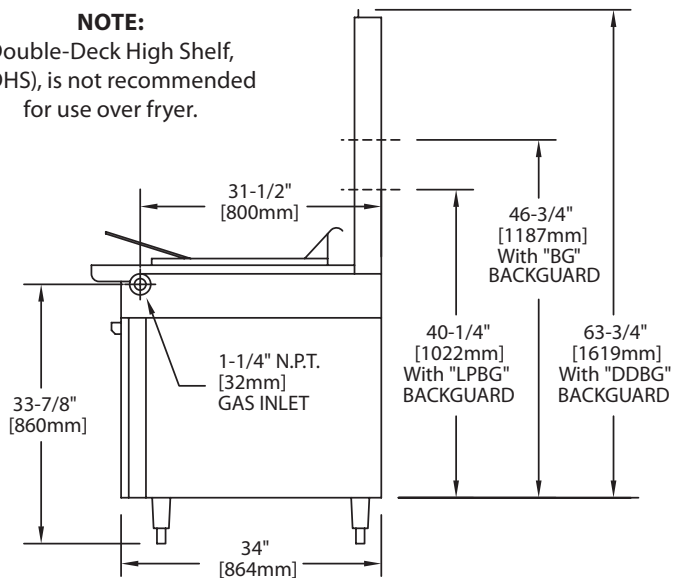

Form# MST35SS (02/14/12)