



SERVICE MANUAL

JACK IN THE BOX

GAS XPRESS GRILLS, MODELS XG24-JIB, XG36-JIB



FOR YOUR SAFETY:
DO NOT STORE OR USE GASOLINE
OR OTHER FLAMMABLE VAPORS OR
LIQUIDS IN THE VICINITY OF THIS OR ANY OTHER
APPLIANCE

WARNING:
IMPROPER INSTALLATION, ADJUSTMENT,
ALTERATION, SERVICE OR MAINTENANCE CAN
CAUSE PROPERTY DAMAGE, INJURY, OR DEATH.
READ THE INSTALLATION,
OPERATING AND MAINTENANCE
INSTRUCTIONS THOROUGHLY
BEFORE INSTALLING OR
SERVICING THIS EQUIPMENT

NOTE:
THIS MANUAL PERTAINS TO ALL XPRESS GRILL
MODELS LISTED ABOVE. THE READER/OPERATOR
MUST INTERPRET ITS CONTENTS TO APPLICABLE
NEEDS. HOWEVER, IF THERE IS ANY QUESTION OF
INTERPRETATION OF ANY LITERATURE PERTAINING
TO GARLAND GRILLS, PLEASE CONTACT OUR
CUSTOMER SERVICE DEPARTMENT AT ONE OF THE
PHONE NUMBERS LISTED BELOW.

MODEL NUMBERS:
XG24-JIB, XG36-JIB

PLEASE READ ALL SECTIONS OF THIS MANUAL AND
RETAIN FOR FUTURE REFERENCE.

THIS PRODUCT HAS BEEN CERTIFIED AS COMMERCIAL
COOKING EQUIPMENT AND MUST BE INSTALLED BY
PROFESSIONAL PERSONNEL AS SPECIFIED.

CAUTION: THIS EQUIPMENT MUST ONLY BE OPERATED
UNDER AN APPROVED HOOD SYSTEM

IN THE COMMONWEALTH OF MASSACHUSETTS
THIS PRODUCT MUST BE INSTALLED BY A LICENSED
PLUMBER OR GAS FITTER.

For Your Safety:
Post in a prominent location, instructions to be
followed in the event the user smells gas. This
information shall be obtained by consulting your local
gas supplier.

GARLAND COMMERCIAL INDUSTRIES, LLC
185 East South Street
Freeland, Pennsylvania 18224
Phone: (570) 636-1000
Fax: (570) 636-3903

GARLAND COMMERCIAL RANGES, LTD.
1177 Kamato Road, Mississauga, Ontario L4W 1X4
CANADA
Phone: 905-624-0260
Fax: 905-624-5669

TABLE OF CONTENTS

DIMENSIONS AND SPECIFICATIONS, XG24-JIB MODEL	4	Enter Standby Mode:	21
DIMENSIONS AND SPECIFICATIONS, ++XG36-JIB MODEL	5	Exit Standby Mode:	21
Plug Configuration	6	To Display the Current Temperatures:	21
INTRODUCTION	7	To View Settings for a Menu Item:	21
Warranty	7	To Clean the Grill:	21
Shipping Damage Claim Procedure	7	PLATEN SET:	21
SAFETY	7	EXTENDED TIME:	22
UNIT INSTALLATION	9	INSTANT ON TIME:	22
Rating Plate Location	9	START DELAY:	22
General Information	9	CLEANING AND MAINTENANCE	22
National Codes Requirements:	9	Cleaning During Operation:	22
Gas Connections, and Pipe Sizing:	9	Daily Cleaning:	22
Appliances Equipped with Casters:	10	PROGRAMMING	24
Electrical Connections:	10	Programming Modes/Menu Sequence:	24
Accessory Kit – Main Gas Inlet:	10	<i>Menu Items...</i>	
Accessory Kit – Electrical Supply Lines:	11	To Change the Cook Time of a Product:	26
Electrical Connection Terminal Block Connection	12	To Turn Platen, (2-Sided), Cooking On/Off:	26
Grease Bucket:	12	To Change Upper Platen Set Temperature:	26
Ventilation and Clearance:	12	To Change Grill Set Temperature:	26
Changing to a different type of gas	12	To Change Product Gap Setting:	26
Burner Air Adjustment	13	To Change Product Button, “Key” Assignment	27
Igniter Adjustment	13	To Change a Product Name:	27
GRILL CONTROLS	14	<i>System Info...</i>	
Master Power Switch:	14	To View Recovery Time - Upper Platen:	27
LED Indicators:	14	To View Recovery Time - Grill:	27
Display:	14	To View the Garland Part Number:	27
Product Buttons (0-9):	14	To View the Flash Number:	28
Power Button:	14	To View the Software Number:	28
Program Button:	15	To View the Download Number:	28
Temperature Button:	15	<i>System Setup</i>	
Up/Down Arrow Buttons; 2 Functions:	15	To Change temperature Units, (°F or °C):	28
Enter Button:	15	To Change Gap Setting Display Units:	28
Cancel/Raise Platen Button, (Green):	15	To Change the Alarm Volume:	29
Black Button:	15	To Change the Key Chirp:	29
Main Pre-Programed Product Items	15	To Change Probe Calibration - Upper:	29
PLATEN ZEROING	16	To Change Probe Calibration - Grill:	29
OPTIONAL ACCESSORIES	18	To Change Platen Set:	30
RELEASE MATERIAL INSTALLATION	19	To Change Instant-On Time:	30
NORMAL OPERATION	20	To Change Control Type:	30
Installing Release Material:	20	To Turn Extended Time On/Off:	30
Lighting Instructions:	20	To Change the Grill Function:	31
Shut Down Instructions	20	To Change the Start Delay:	31
To Cook in Two-Sided Mode:	20	To Change the Alarm Mode:	31
To Cook in Flat Grill Mode:	20	To Turn Clean Mode On/Off:	31
		To Add a Product Name in Library:	31
		To Modify a Product Name in Library:	32
		<i>Service Mode</i>	
		To Change SCK Address:	32
		To Perform Limit Switch Test:	32

TABLE OF CONTENTS *continued*

CALIBRATION	33	LINEAR ACTUATOR REPLACEMENT	46
Bi-Weekly Calibration:.....	33	PARTS LIST	49
Probe Locations:.....	34	XG24-JIB XPRESS GRILL GAS	
TROUBLESHOOTING	35	XPRESS - GRILL COMPLETE VIEW.....	50
ERROR MESSAGES:		XPRESS GRILL ACTUATOR.....	52
PROBE ERROR:	35	XPRESS GRILL PLATEN.....	54
PLATEN DOWN ERROR:.....	35	XPRESS GRILL BURNER	56
PLATEN UP ERROR:.....	35	XPRESS GRILL COMPONENT BRACKET	58
HEATING ERROR:.....	35	XPRESS GRILL HEAT SINK	60
COMM ERROR:	35	REVISION HISTORY	62
MOTOR OVER CURRENT:.....	35	XG36-JIB XPRESS GRILL GAS	
MOTOR ERROR:	35	GRILL COMPLETE ASSEMBLY	64
IGNITION ERROR:.....	35	ACTUATOR ASSEMBLY.....	68
FLASHING LED(S):.....	35	PLATEN ASSEMBLY	70
TECHNICAL TROUBLESHOOTING	36	XPRESS GRILL BURNER	72
Master Power (ON / OFF) Switch turned ON -		XPRESS GRILL BRACKET	74
Power light or indicator is not lit	36	XPRESS GRILL HEAT SINK	76
Low Internal Product Temperatures.....	36	WIRING HARNESS AND DESCRIPTION WHERE USED ...	78
Controller Displays "Too Hot"	37	ACCESSORIES AND TOOLS.....	79
Controller Displays "FAULTY ELEMENT OR SHORTED		GAS TUBING	80
PROBE" -Only 1 or 2 zones LED lights are RED	38	REVISION HISTORY	81
Controller displays "PROBE ERROR"	39	WIRING DIAGRAM	82
Controller Displays "HEATING ERROR or PROBE		CONTROLLER MENU ITEMS	84
ERRORPLATEN and GRILL LED's are RED (Both Sides)...	40	TEMPERATURE CONVERSION (F / C)	85
Inconsistent Or Erratic Internal Product Temperature ...	40		
Controller Display is BLANK, Main Power (ON / OFF)			
light or indicator is LIT.	41		
Master Power (ON / OFF) Switch turned ON -			
Power Light in On - Grill is not heating	42		
Controller Displays "MOTOR OVER CURRENT" -			
Platen does not move at all.....	43		
Controller Displays "MOTOR OVER CURRENT" -			
Platen stops and moves to lower limit	43		
Controller Displays "IGNITION FAILURE" -			
No flame at all	44		
Controller Displays "IGNITION FAILURE" -			
Flame does not light at all	44		
Controller Displays "IGNITION FAILURE" -			
Module is sparking, flame comes on and goes out	45		

DIMENSIONS AND SPECIFICATIONS, XG24-JIB MODEL

Model	Total kW Load	Loading kW Per Phase			Nominal Amps Per Line					
		208/240V 3ph			208V 3-Phase Delta		240V 3-Phase Delta			
		X-Y	X-Z	Y-Z	X	Y	Z	X	Y	Z
XG24-JIB	8.66	2.66	3.33	2.66	24.90	22.14	24.90	21.61	19.19	21.61

6' (1.83m) electric cord and plug included in supplied accessory kit: 240V models are supplied with a #4-10AWG cord with a NEMA 5-30P plug, kit # 4525509. 208V models are supplied with a #4-6AWG cord with a NEMA 15-50P plug, kit # 4524785.

Clearances				Gas Pressure				Total Gas Input	
Entry		Installation		Supply (min.)		Operating			
Crated	Uncrated	Sides	Rear	NAT	PRO	NAT	PRO	BTU/Hr	kW
47-1/2" (1207mm)	32" (813mm)	6" (152mm)	3" (76mm)	7.0" WC	11.0" WC	3.5" WC	3.5" WC	66,000	19.4

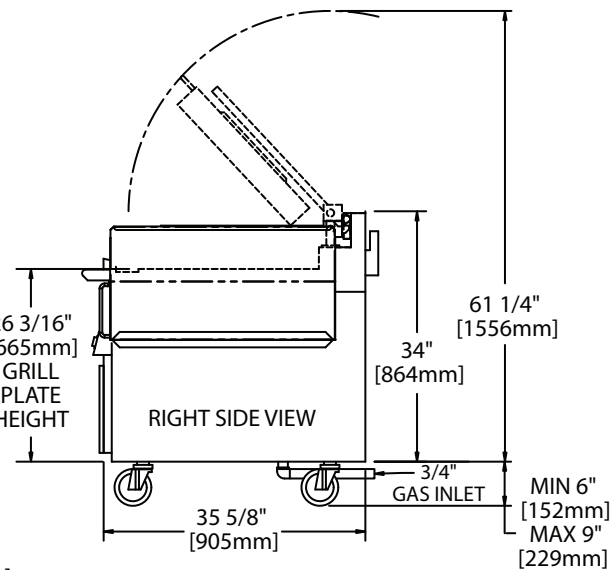
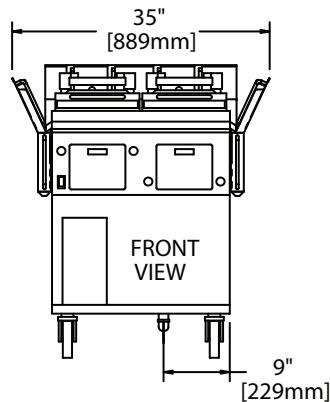
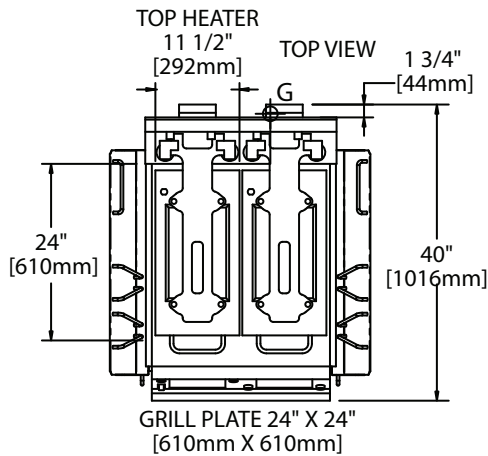

TOLERANCE
+/- 1/8" [3mm]

Shipping: Weight 575Lbs/ 234Kg, 45 Cubic Feet

Garland products are not approved or authorized for home or residential use, but are intended for commercial applications only. Garland will not provide service, warranty, maintenance or support of any kind other than in commercial applications

Gas input ratings shown here are for installations up to 2,000 Ft. (610m) above sea level. Specify altitudes over 2,000 Ft.

DIMENSIONS AND SPECIFICATIONS, XG36-JIB MODEL

Model	Total kW Load	Loading kW Per Phase			Nominal Amps Per Line					
		208/240V 3ph			208V 3-Phase Delta		240V 3-Phase Delta			
		X-Y	X-Z	Y-Z	X	Y	Z	X	Y	Z
XG36-JIB	12.99	4.00	4.99	4.00	37.43	33.30	37.43	32.43	28.90	32.43

6'(1.83m) electric cord and plug is included in the supplied kit : 208V or 240V models are supplied with a #4-6AWG cord with a NEMA 15-50P plug, kit #4524785

Clearances				Gas Pressure				Total Gas Input	
Entry		Installation		Supply (min.)		Operating			
Crated	Uncrated	Sides	Rear	NAT	PRO	NAT	PRO	BTU/Hr	kW
47-1/2" (1207mm)	40-3/4" (1035mm)	6" (152mm)	3" (76mm)	7.0" WC	11.0" WC	3.5" WC	3.5" WC	99,000	29.1

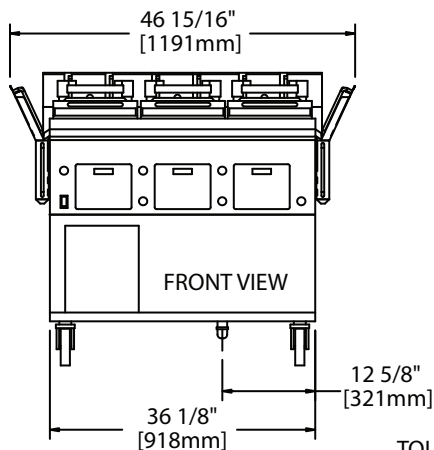
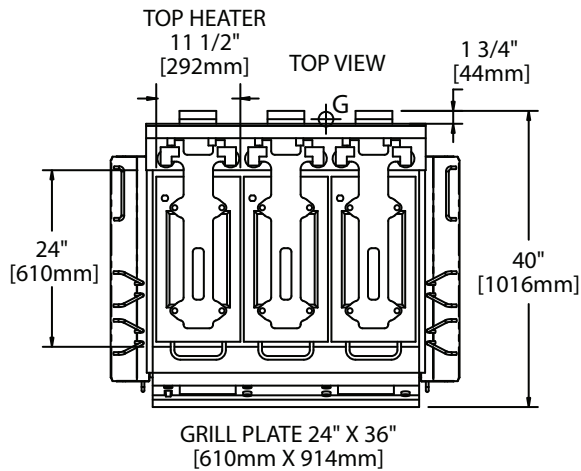

TOLERANCE
+/- 1/8" [3mm]

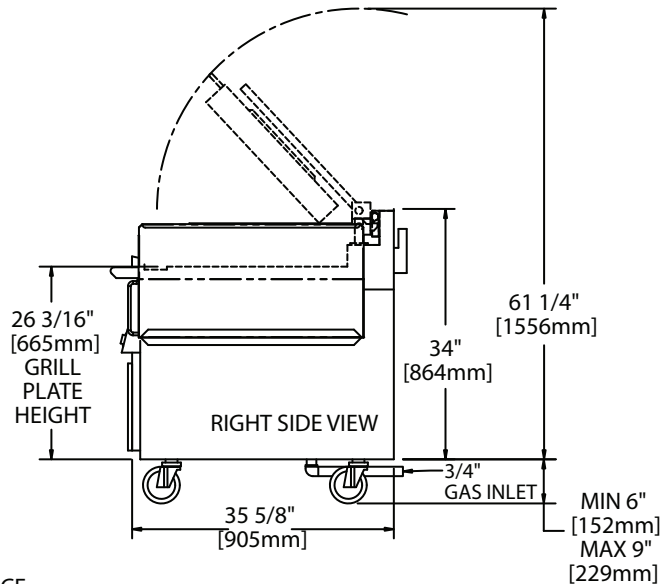

Shipping: Weight 965Lbs/ 438Kg, 59 Cubic Feet

Garland products are not approved or authorized for home or residential use, but are intended for commercial applications only. Garland will not provide service, warranty, maintenance or support of any kind other than in commercial applications

Gas input ratings shown here are for installations up to 2,000 Ft. (610m) above sea level. Specify altitudes over 2,000 Ft.

SPECIFICATIONS *continued*

Plug Configuration

The grill is supplied with an electrical power supply cord and plug to match the specific voltage as it was constructed. The following table shows the correct plug configuration to match the model and voltage.

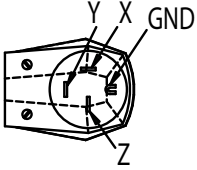
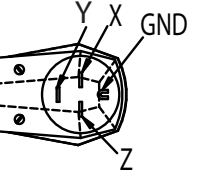
Xpress Grill Cord and Plug Configuration							
P/N (includes electrical and gas inlet plumbing)	Plug Type	Cord Gauge Supplied	NEMA Plug	Model	Voltage (3ph Delta)	Maximum Current (Amps)	Minimum Cord Gauge
4524785		4-6AWG	15-50P	XG24-JIB	208	24.90	4-10AWG
				XG36-JIB	208	37.43	4-6AWG
					240	32.43	4-8AWG
4525509		4-10AWG	15-30P	XG24-JIB	240	21.61	4-10AWG

INTRODUCTION

The Garland Xpress grill, for Jack in the Box provides a method for efficient two-sided cooking, while accommodating a variety of products. The unit will also serve as a flat grill, and meets all of Jack in the Box's standards for safety, efficiency, and cleanliness.

Warranty

This warranty covers defects in material and workmanship under normal use providing that:

- a) The equipment has not been accidentally or intentionally damaged, altered or misused.
- b) The equipment is properly installed, adjusted, operated and maintained in accordance with national and local codes and in accordance with the installation instructions provided with this product.
- c) The warranty serial number affixed to the appliance by Garland has not been defaced, obliterated or removed.
- d) An acceptable report for any claim under this warranty is supplied to Garland.

The equipment warranty coverage remains in force for one (1) year (parts and labor) from the date the equipment is put into operation.

The Garland Group agrees to repair or replace, at it's option, any part that proves to be defective in material or workmanship at no charge for the part or normal labor.

We assume no responsibility for installation, adjustments, diagnosis, or normal maintenance such as: lubrication of springs or valves. We exclude failures caused by erratic voltage or gas supplies. We assume no responsibility for travel costs beyond 100 miles round trip, travel other

than overland, and overtime costs of repair. We exclude broken glass, paint and porcelain finish, surface rust, gasket material, ceramic material, light bulbs and fuses from normal coverage. We exclude damage or dysfunction caused by fire, flood, and like "Acts of God" that are beyond the control of The Garland Group.

The Garland Group's liability on a claim of warranty shall not exceed the price of the material and/or service, which caused the claim. This warranty is limited and is in lieu of all other warranties, expressed or implied. The Garland Group, our employees, or our agents shall not be held liable for any claims of personal injury or consequential damage or loss. This warranty gives you specific legal rights, and you may have other rights which vary from state to state.

Shipping Damage Claim Procedure

Please note that the Garland equipment was carefully inspected and packed by skilled personnel before leaving the factory. The transportation company assumes full responsibility for safe delivery upon acceptance of the equipment.

What to do if the equipment arrives damaged:

1. File a claim immediately regardless of the extent of damage.
2. Be sure to note, "visible loss or damage," on the freight bill or express receipt and have the person making the delivery sign it.
3. Concealed loss or damage: if damage is unnoticed until the equipment is unpacked, notify the freight company immediately, (within 15 days), and file a concealed damage claim.

SAFETY

Always follow these safety precautions when operating the Xpress Grill.

- **THIS GRILL MUST** be operated by persons who have been given adequate training.
- **THIS EQUIPMENT MUST ONLY BE OPERATED UNDER AN APPROVED HOOD SYSTEM.**
- **DO NOT OPERATE THE GRILL UNLESS IT HAS BEEN COMMISSIONED (START-UP) BY A FACTORY AUTHORIZED SERVICE CENTER.**
- **DO NOT** operate the grill without reading the operation manual.

- **DO NOT** operate the Xpress grill unless it has been properly installed and grounded.
- **DO NOT** operate the Xpress grill unless all service and access panels are in place and fastened properly.

The Garland Xpress Grill is a semi-automatic cooking appliance. The upper platen is lowered automatically, following the manual, two-handed initiation of the cooking cycle, and the upper platen is raised automatically upon completion of the cooking cycle.

SAFETY *continued*

When two sided cooking, the area between the upper platen and the griddle plate should be regarded as a "danger zone." During two sided cooking the operator must not be within this danger zone. When used as a flat grill, then this area is no longer a danger zone, the platens do not move.

For whatever reason, be it cleaning, maintenance, or normal operation, any exposed person must use extreme caution if within this danger zone.

In two side cooking the upper platen remains in the lowered position by nature of its own weight. It is not locked down. It can be raised by lifting up on the handle on the front of the platen, which pivots the platen about its rear mounting point.

The Xpress Grill may during its operation emit airborne noise equivalent to a continuous A weighted sound pressure level of 73dB(A).

The Xpress grill must only be used for single and two sided cooking of foodstuffs in a Jack in the Box store and must not be used for any other purpose.

WARNING: To avoid serious personal injury:

- **DO NOT** attempt to repair or replace any part of the Xpress Grill unless all main power supplies to the grill have been disconnected.
- **USE EXTREME CAUTION** in setting up, operating and cleaning the Xpress Grill to avoid coming in contact with hot grill surfaces or hot grease. Suitable protective clothing should be worn to prevent the risk of burns.
- **DO NOT** clean this appliance with a water jet.
- **DO NOT** apply ICE or COLD WATER to a HOT grill surface.
- **NOTE** all warning labels and markings affixed to the grill, since they call attention to further dangers and necessary precautions.

HAZARD COMMUNICATION STANDARD, (HCS) - The procedures in this manual include the use of chemical products. These chemical products will be printed in bold face, followed by the abbreviation (HCS) in the text portion of the procedure. See the Hazard Communication Standard, (HCS) manual for the appropriate Material Safety Data Sheet(s), (MSDS).

WARNING: After turning the master power switch to the START position, the grill will go through initialization. If the upper platens are in the lowered position they will return to their raised upper position. This movement takes approximately 8 seconds.

MAINTENANCE - the platen support arms carriage block bearing bushings, the platen adjuster nuts, the platen support (shoulder) bolt and the cam follower should be checked annually for wear. Should there be any noticeable play in the bearing bushings and any visible wear on the platen adjuster nuts, platen support bolts or cam follower, then they must be replaced.

MAINTENANCE - the audible alarm that sounds on platen lowering, platen raising and 5 seconds before the completion of the cooking cycle is to advise the operator that the platen is about to move. The function of this device may be tested by pushing the left hand CANCEL button. If no sound is heard, ensure that the alarm volume is not set to low in SYSTEM SETUP. If there is still no sound then a service engineer should be called out to rectify the fault.

SERVICE AND CLEANING - The grill is secured in the grill bay by the installer using two anchors that lock onto the front casters. If the grill is to be moved out of the bay for cleaning or service, remove the anchor from each caster by turning the knob counterclockwise to loosen the retainer. When the retainer is free of the caster, lay the assembly aside on the floor.

After service or cleaning is complete, return the grill to its position in the bay and reattach the anchors by placing the retainer on the caster post and turning the knob clockwise to tighten.

NOTE: For safety reasons, the grill must be secured in the grill bay in this manner before operation can resume.

UNIT INSTALLATION

Rating Plate Location

IMPORTANT: Rating plates for this appliance are located in two places: 1) inside back panel on left side, 2) under front control panel on center.

General Information

This equipment must be installed by a competent factory trained, certified, licensed and / or authorized service or installation person.

WARNING: This appliance must be properly grounded.

Prior to installation, the four casters, supplied loose with the grill, must be securely located on the underside of the base. The casters fitted with a brake must be located at the front of the grill.

This appliance should be connected to a potential equalization system. A labeled equipotential bonding point is fitted to the rear of the grill.

It is recommended that this grill be connected to a residual current (earth leakage) device with a tripping current not exceeding 30mA. The leakage current of this grill will not exceed 5mA.

CAUTION: Prior to installation, check the electrical supply to ensure input voltage and phase match the equipment voltage rating and phase. See data plate located rear left side of grill and lower front panel.

Grill is to be located directly under ventilation system.

Once installed in the grill station underneath the ventilation system, the platens, in their highest position, must not interfere with the lower lip of the ventilation system hood. The raised position of each platen is adjusted by raising or lowering the upper of the two microswitches, (limit switches), in the rear of the grill. The lower microswitch position must not be adjusted.

Grill plate must be level front to back, side to side and diagonally. This leveling must be done with the unit under the hood and in its normal operational position to prevent warping of the grill plate.

NOTE: Once the platen elevation is adjusted, set the mechanical over-run bolts in the rear of the unit to prevent accidental over-run in the event of failure of the upper microswitch.

NOTE: Fuses are installed to prevent damage in the event of failure of the upper microswitch.

Installation shall be made with the gas connector that has been specified by The Jack in the Box Corporation and is supplied loose with the grill. The quick disconnect fitting and gas shut off valve must be installed in the direction indicated on their outer body.

NOTE: When checking gas pressure, be sure that all other equipment on the same gas line is on.

The appliance and its individual shut-off valve must be disconnected from the gas supply piping system during any pressure testing of that system pressures in excess of 1/2 PSIG (3.45kPa, 14"WC).

Adequate clearance must be provided for servicing and proper operation.

National Codes Requirements:

The type of gas for which the grill is equipped is stamped on the data plate on the inside rear of the unit and on the lower front panel. Connect a grill stamped for Natural Gas (High (H) or Low (L) Calorific Value) only to Natural Gas; connect those stamped for Propane Gas only to Propane gas.

The installation must conform to the National Fuel Gas Code ANSI Z223.1-1998 or latest edition, NFPA No. 54 – latest edition and National Electrical Code ANSI/NFPA 70-1990 or latest edition and/or local code to assure safe and efficient operation. In Canada, the installation must comply with CSA B149.1 and local codes where applicable.

In Canada, electrical connection must comply with applicable sections of the Canadian Electrical Code, C22.1 - 1990, latest edition, "Safety Standard for Installation, Part 1" and C22.2- No. O-M 1982 latest edition, "General Requirements, Part 2".

Gas Connections, and Pipe Sizing:

The size of the gas line is very important. If the line is too small, the gas pressure at the burner manifold will be low. This will cause slow recovery and delayed ignition. The incoming gas pressure line should be a minimum of 1-1/2". All grills require a 3/4" connection.

Before connecting new pipe the pipe must be blown out to dispose of any foreign particles. These particles will cause improper operation.

When using thread compound, use small amounts on male threads only. Use a compound that is not affected by the chemical action of LP gases. Avoid applying compound to the first two threads to prevent clogging of the burner orifices and control valve.

Have the installer check all gas plumbing with a soap solution for leaks. DO NOT USE matches, candles or other ignition sources in checking for leaks.

UNIT INSTALLATION *continued*

The grill must be disconnected from the gas supply system when pressure testing of that system at pressures in excess of 1/2 psi (3.45kPa).

Check the data plate to determine the proper type of gas before connecting the quick disconnect or piping from the building gas supply.

An incoming gas pressure test nipple is provided on the incoming gas manifold for pressure checks.

Minimum incoming gas pressure for Natural Gas is 6" W.C.
Maximum incoming gas pressure for Natural Gas is 13" W.C.

Minimum incoming gas pressure for Propane is 10" W.C.
Maximum incoming gas pressure for Propane is 13" W.C.

Burner operating gas pressure can be checked at the outlet side of the gas valve at the pressure test point.

Burner manifold pressure for Natural Gas must be 3.2" W.C.;
Burner pressure for Propane must be 3.5" W.C.

To adjust the burner pressure, remove the sealing screw from the pressure test nipple, connect a manometer, remove the sealing cap on the gas valve regulator, turn on the grill, adjust the screw in the regulator to give the correct pressure, turn off the grill, refit the regulator sealing cap, remove the manometer, replace the seal screw in the test nipple and test for gas leaks.

Gas pressures should be checked by the local Gas Company or an authorized service agency only.

Test all piping and connections for gas leaks. A rich soap solution should be used for this purpose. Never use a flame.

Appliances Equipped with Casters:

1. The installation shall be made with a connector that complies with the Standard for Connectors for Moveable Gas Appliances, ANSI Z21.69/CSA 6.16, Addenda Z21.69B-2006/CSA 6.16B-2006 (or latest edition), and a quick-disconnect device that complies with the Standard for Quick Disconnects for Use with Gas Fuel, ANSI Z21.41/CSA 6.9, Addenda Z21.41A-2005/CSA 6.16A-2005 (or latest edition).
2. The front casters on the appliance are equipped with brakes to limit the movement of the appliance without placing any strain on the connector or quick-disconnect device or its associated piping.
3. Please be aware; required restraint is attached to a bracket (which is located on the rear caster closest to the gas connection), and if disconnection of the restraint is necessary; be sure to reconnect the device after the appliance has been returned to its original position.



Electrical Connections:

All electrically operated appliances must be electrically grounded in accordance with local codes; or in the absence of local codes, with the latest edition of National Wiring Regulations. A wiring diagram is located on the rear panel of the grill. See rating plate in rear of grill, or lower front panel for proper voltages.

Accessory Kit – Main Gas Inlet:

(Accessory kit part numbers 4524785 or 4525509 and also includes electrical supply lines, see next section).

Each griddle is supplied with an extended rear gas manifold kit., with the following parts.

DESCRIPTION	PART DRAWING	QTY.
3/4"x 3/4" 90 Degree Elbow		1
Nipple Assembly		1
Manifold Support Bracket		1
10-24 x 1/2 Quadrex Pan HD Type F Screw		4

Installation of Kit:

- A. Install the elbow on the end of manifold (3/4" NPT) underneath the griddle, tighten and align with the elbow facing the back of the unit. Refer to Photo A.

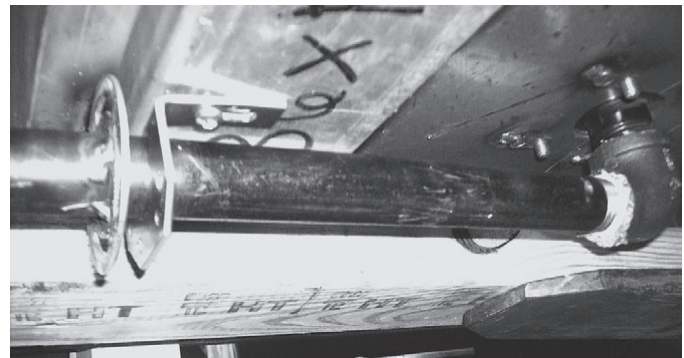

Photo A

UNIT INSTALLATION *continued*

- B. Install the nipple assembly into the elbow (3/4" NPT)
Refer to Photo A
- C. Install the manifold support bracket over the nipple attaching it to the circular bracket on the nipple. Do not tighten screws. Refer to Photo B

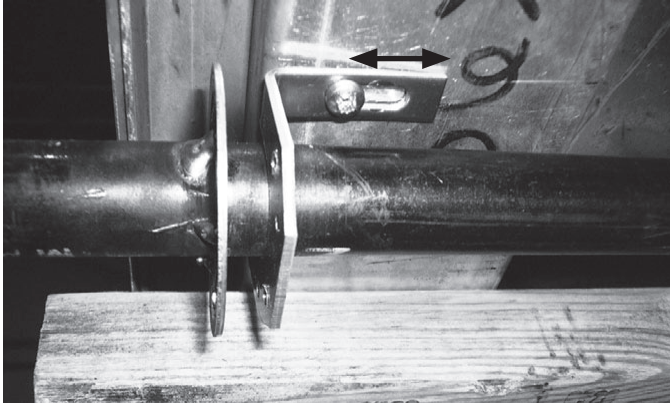

Photo B

- D. Adjust the manifold support bracket flush with the rear gas support bracket. Refer to Photo B
- E. Tighten the loose screws of the manifold support bracket. Refer to Photo B
- F. Lock the two brackets together using two screws. Refer to Photo C

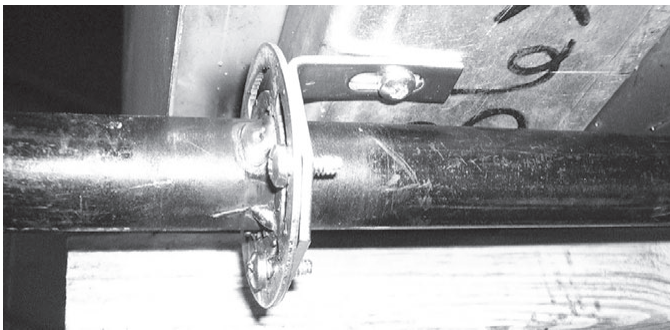

Photo C

Accessory Kit – Electrical Supply Lines:

The accessory kit also contains electric power cord and plug and has a strain relief suited for each unit. Refer to Plug Configuration in SPECIFICATIONS and Photo D

Installation of Cord And Plug With Strain Relief:

1. Remove the left grease bucket support attached by two metal screws and the stainless steel left side body panel attached by five metal screws.
2. Remove the cord & plug and strain relief assembly from the accessory kit. Refer to photo D.



Photo D

3. Remove the locknut from at the end of the cord. Refer to photo E.

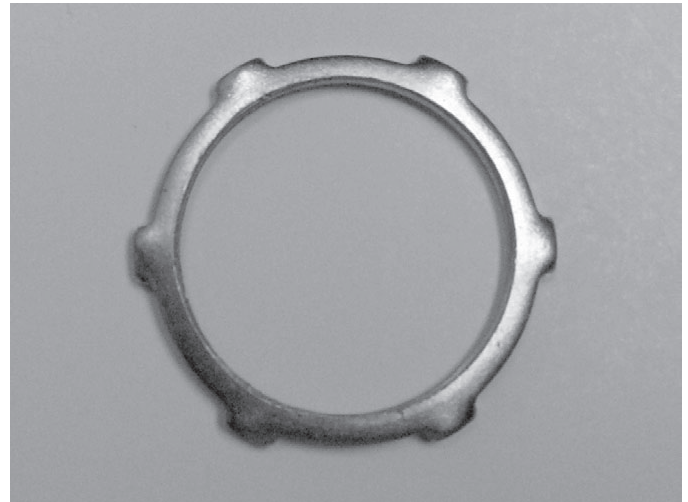

Photo E

UNIT INSTALLATION *continued*

4. Insert loose wires and strain relief cord end through the hole at the bottom of the unit. Refer to photo F and secure with locknut. Refer to photo E.

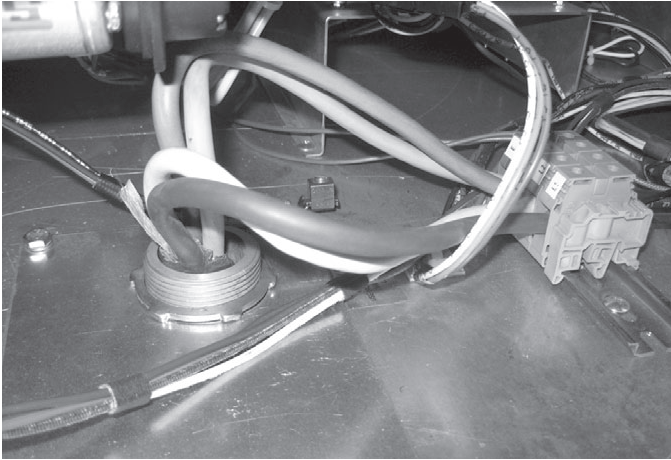

Photo F

5. Attached wire ends to terminal block as shown in next section and referenced in wiring diagrams at back of this manual.
6. Reinstall the side panel and grease bucket support with metal screws. The external electrical connection should appear as in photo G.

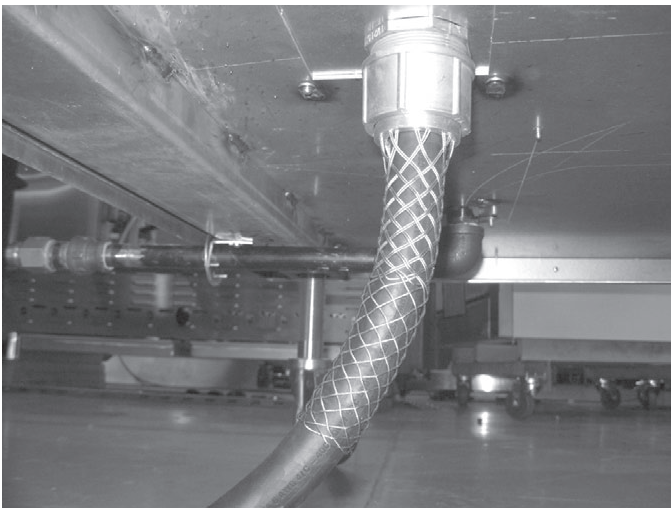
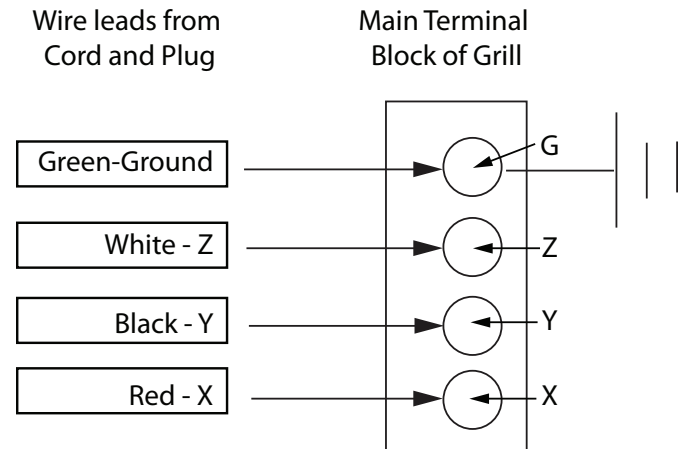

Photo G

Electrical Connection Terminal Block Connection

All electrically operated appliances must be electrically grounded in accordance with local codes; or in the absence of local codes, with the latest edition of National Wiring Regulations. A wiring diagram is located behind the rear panel of the grill. See rating plate in rear of grill, or lower front panel for proper voltages.

Note: see diagram below for connections to terminal block.



Grease Bucket:

The griddle is supplied with two stainless steel side grease buckets that must be installed before the unit is used. Each bucket slides into position along stainless steel supports.

Ventilation and Clearance:

One of the most important considerations for efficient grill operation is proper ventilation and air supply. Insure the grill is installed so the products of combustion are removed efficiently and the ventilation system does not produce drafts that interfere with proper burner operation.

Proper operation of exhaust fans (speed, rotation and adjustment) is essential. In addition to the exhaust system the make-up air system, (HVAC), for the kitchen is the air supply for the combustion air for the burners. Proper incoming air is essential for all gas operated equipment. Poor incoming make-up will cause inefficient burner operation, delayed ignition and possible burner failure.

Any ventilation system will break down if improperly maintained. The duct system, the hood, and the filters must be cleaned on a regular basis and kept grease free.

The room containing the grill is required to have a permanent air vent. The minimum effective area of the vent shall be 0.7 in.² per kW. Air vents shall be of such a size to compensate for the effects of any extract fan in the premises.

Changing to a different type of gas

Changing from one gas type to another must only be done by a Qualified Gas Engineer and according to local regulations.

UNIT INSTALLATION *continued*

The gas valve, enrichment tube igniter and orifice must be changed to that supplied by the Authorized Service Agency for the gas you are changing to. On completion of changing these three components, you should test all joints for leaks, verify that the manifold pressure is adjusted to the value given in the specification pages in this manual, and repeat the burner air adjustment procedure. This is to be found on the following page in this manual. When the burner is correctly adjusted, the alternate rating plate decal must be placed over the existing rating plates to reflect the new category for which the grill is set.

To change from one gas type to another within the same category (High to Low Calorific Value Natural Gas or vice versa), change the orifice to that supplied by the Authorized Service Agency.

Burner Air Adjustment

1. The Xpress Grill gas model burner is a stainless steel rectangular assembly that receives forced air from a fan mounted below the burner. The fan air quality can be slightly adjusted if the flame quality is poor to the point that the flame sensor will be unreliable.
2. Loosen the lock nut holding the air adjustment in place. Slowly turn the air adjustment out (counterclockwise). The flame should be stable (no lifting) and be 1/8" to 1/4" predominately blue.

Igniter Adjustment

The Igniter location is factory set and does not normally require adjustment. Adjustment should only be conducted if the Micro-Amp (μA) reading taken by placing a Micro-Amp (μA) meter in line between the ignition module and the flame sense wire reads below 0.22 Microamps (μA). The normal reading is around 0.80 (μA) to 1.5 (μA). If the reading is low, the igniter can be moved up or down to achieve the proper signal. The following is a description of the process.

Note: the correct air fuel mixture and gas pressures must be obtained before proceeding with igniter adjustment

1. Loosen the two 5/16" hex head #10 screws just outboard of the igniter. This allows the igniter and its bracket vertical movement.
2. With the Microamp meter in the flame sense line, and the adjustment screws just loose enough to be able to move the igniter assembly up and down, ignite the burner and move the igniter up and down until the maximum Microamp reading is achieved.
3. Tighten up the adjuster screws and the job is complete.

Igniter Inspection

The igniter is next to the flame sensor in the burner compartment. Normally, it should not require any adjustment. If, however, the gap between the igniter tip and the burner is too great, or the igniter seems to generate a weak spark, replace the igniter, and recheck the new component for normal operation.

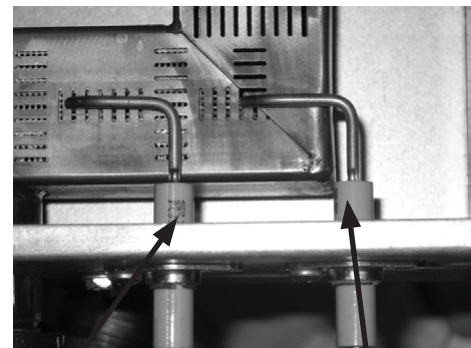

IGNITOR

FLAME SENSOR

GRILL CONTROLS

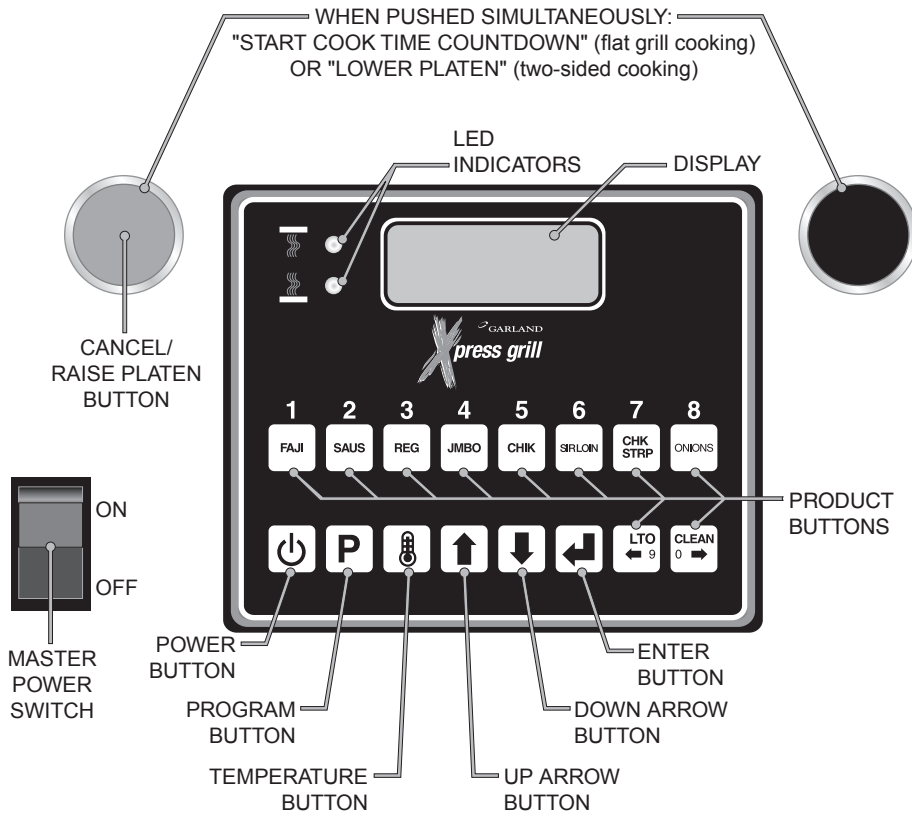

Master Power Switch:

Controls power to the grill and must be turned "ON" to start operation. The controller display will be active when the switch is "ON".

LED Indicators:

There are two, (2), indicator lights, indicating the temperature status of each control's heat zones; one, (1), on the upper platen, (top light), and one, (1), on the grill surface. Each light can display three, (3), different colors, indicating temperature status for the corresponding zone.

Red: The zone is too hot, (more than 79°F/45°C over the set temperature), or heat zone failure.

Amber: The zone is calling for heat.

Green: The zone is at or above the set temperature.

Display:

The controller display will contain information relevant to each operation in both cook and program modes.

Product Buttons (0-9):

Buttons 0-9 can be assigned to product items. Buttons 9 and 0 are used to move the cursor left or right when creating or modifying product names in "PROD NAME LIB" program mode.

Power Button:

After the main power switch is turned on, this button will put the control into cook mode. If pressed again, the control will go back to displaying "OFF".

GRILL CONTROLS *continued*

Program Button:

The primary function is to access Programming and Calibration of the grill. Push and hold for five (5) seconds. Display will ask for the code. After entering code, five programming features will be accessible "MENU ITEMS," "SYSTEM INFO," "SYSTEM SETUP," "SERVICE MODE," and "PRODUCT NAME LIB."

Temperature Button:

In the Cook mode, each time the button is pressed the current temperature for one zone is displayed. The grill temperature is displayed first followed by the platen temperature. After five (5) seconds, the display will return to the menu item selected.

Up/Down Arrow Buttons; 2 Functions:

1. In the cook mode, the Up/Down Arrow Buttons will cycle through the different menu items.
2. In the program mode, the Up/Down Arrow Buttons will change the value of the current setting.

Main Pre-Programed Product Items

Product Name	Menu Name	Button Name	Cook Time	Gap Setting	Top Temp	Bottom Temp	Assign to #
Fajitas	Fajitas	FAJI	1:16	0.300	425	335	1
Sausage	Sausage	SAUS	2:00	0.380	425	335	2
Regular	Regular	REG	1:15	0.300	425	335	3
Jumbo	Jumbo	JUMBO	2:50	0.470	425	335	4
Chicken Fillet	Chicken	CHIC	1:40	0.460	425	335	5
Sirloin Patties	SIRLOIN	SIRLOIN	2:00	0.600	425	335	6
Chicken Strip	Chicken Strip	CHK STRP	1:27	0.430	425	335	7
Grilled Onions	Onions	ONIONS	3:00	FLAT	425	335	8
		*LTO					9

*LTO = Limited Time Offer = presently left open.

Enter Button:

Function is to accept programming steps.

Cancel/Raise Platen Button, (Green):

During the cooking cycle, pressing this button will cancel the cooking timer and return the grill to the "IDLE" mode. This button will also bring the grill out of STANDBY.

Black Button:

When both Black and Green "CANCEL/RAISE" buttons are pressed simultaneously, the upper platen will lower to the griddle surface.

PLATEN ZEROING

Turn Master power switch "ON", wait for controllers to display "OFF".

Note: Release sheets should not be installed during this procedure.

1. Press and hold **P** for three, (3) seconds. "ENTER CODE" is displayed.
2. Using the Product buttons, 0-9 enter the code, (1251). "ENTER CODE ****" is displayed.
3. Press **□** to enter the Programming Mode. "PROGRAMMING MODE MENU ITEMS" is displayed.
4. Press **1** two, (2) times in succession to display "PROGRAMMING MODE SYSTEM SETUP".
5. Press **6** six, (6) times. "PLATEN SET +/- XX" is displayed. (XX=numbers that will vary from grill to grill.)
6. Allow time for grill to heat and turn ready. Press both the Cancel (Green) and Standby (Black) buttons simultaneously to lower the upper platen. Press the Cancel (Green) button to raise the platen. Now, press both the Cancel (Green) and (Black) Buttons to re-lower the platen.
7. Remove platen adjuster caps from all four adjustment points on each platen. Remove the four locking caps from the adjustment points.
8. Using the adjusting tool lower platen until adjusting tool touches the arm assembly.
9. With gapping tool, adjust right rear of platen until the gapping tool fits snugly between the upper platen and grill surface.

10. Move next to the left front adjuster and raise the platen until the gapping tool fits snugly between the upper platen and grill surface.
11. Next go to the left rear adjuster and raise the platen until the gapping tool fits snugly between the upper platen and grill surface.
12. Move next to the right front adjustment and raise the platen until the gapping tool fits snugly between the upper platen and grill surface.
13. Repeat steps 9-12 one or more times until gapping tool fits snugly between the upper platen and grill surface at all four adjustment points without further adjustment. (See diagram below.)
14. Replace the platen adjuster locking caps "hollow side down" and tighten snugly. Replace platen adjuster caps.
15. Repeat steps 9-14 for each platen.

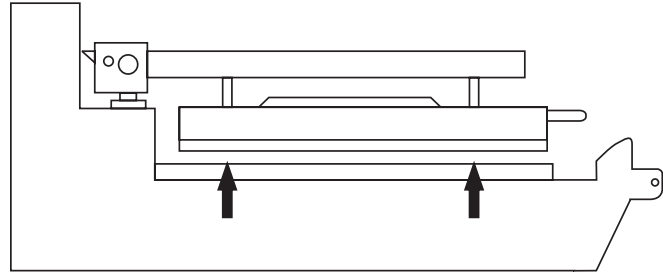

Insert gap tool directly below platen adjusters.

PLATEN ZEROING *continued*

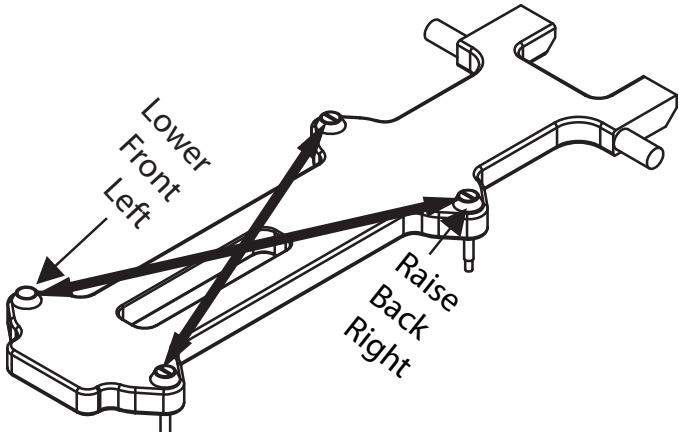

Platen leveling should be done from one corner to the opposite corner. The adjuster nuts should be turned opposite of one another.

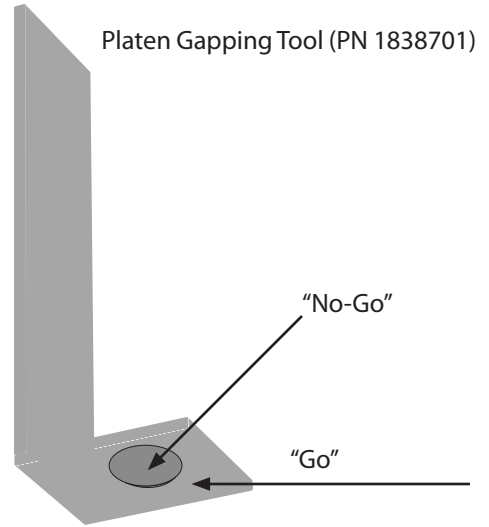

Platen Adjusting Tool (PN 4523323)

This end to remove Adjuster Locking Cap

This end to remove Grease Cap and to make adjustments to the adjuster nuts

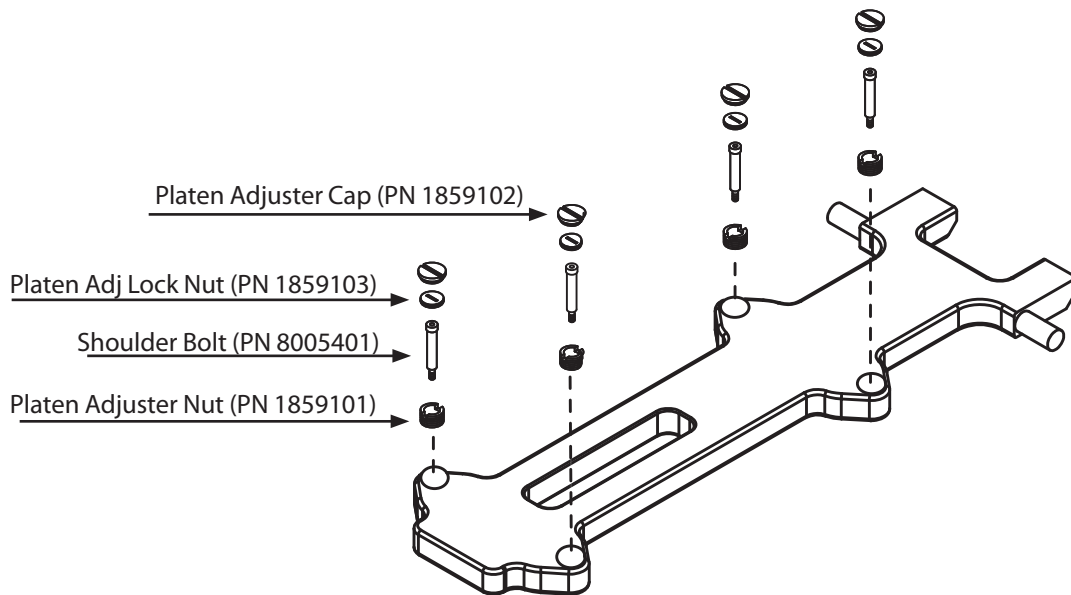
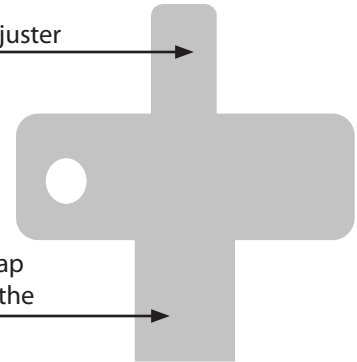

OPTIONAL ACCESSORIES

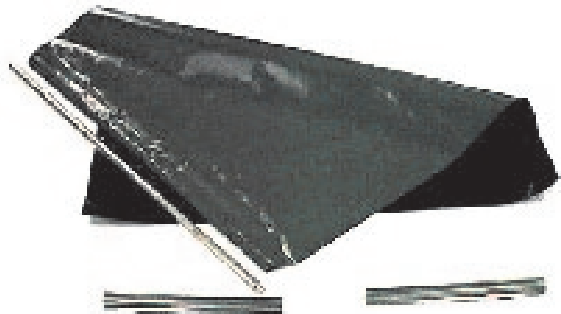

Teflon Sheet - 1799302
Teflon Clip - 1851303



Grill Squeegee - 1868201

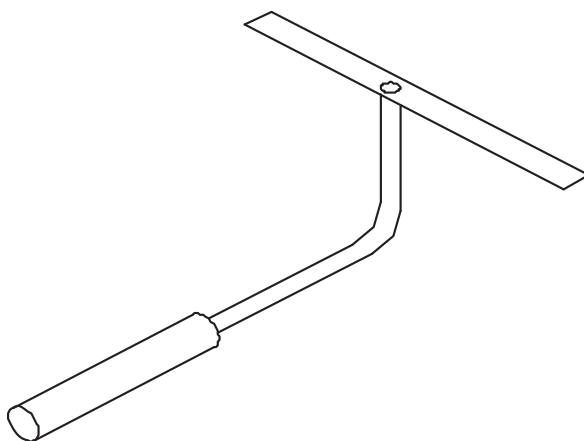

Teflon Tool - 4525560

RELEASE MATERIAL INSTALLATION

The following procedures are the procedures for installing the Teflon sheets on to the upper platen on the Garland Xpress grill. The components shown below are included with your grill when purchased.

Slide release material rod through hemmed end of the release material sheet.

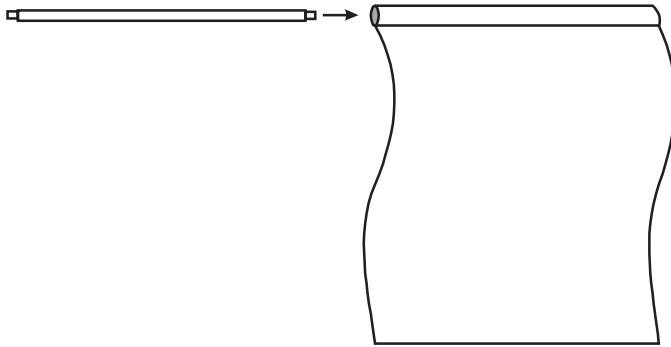

Hook release material rod on brackets located at the rear of the upper plate

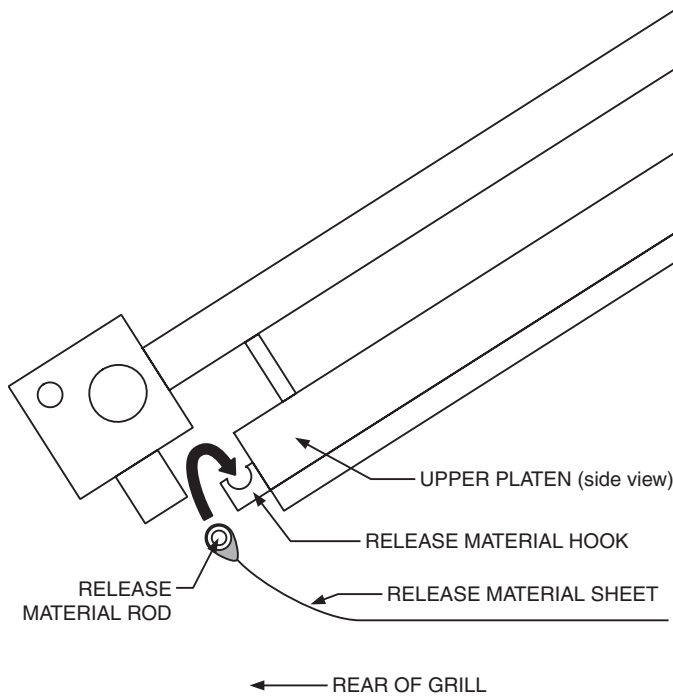

Holding the bottom of the release material sheet in place, gently pull the sheet toward the front of the platen.

Thread the front edge of the release material sheet behind the release material bar on the front of the platen, then around the top and down over the front of the bar as shown.

Place locking clips over release material sheet and press into place over release material bar.

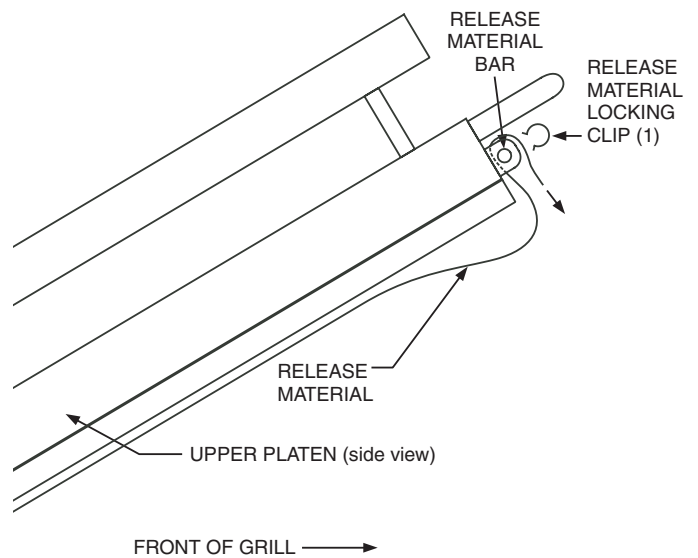

Check alignment and tightness of release material against upper platen.

NOTE: Make sure release material fits smoothly over upper platen. Installing release material sheets too tight may cause premature failure of the sheet.

Release sheets are reversible and should be flipped over and reattached on a daily basis. For instructions on cleaning release sheets, see Step 17, Under Daily Cleaning in Cleaning and Maintenance section.

A release material sheet must be replaced when:

- Product sticks to release material.
- Carbon build-up ruins taste or appearance.
- Tearing occurs in the sheet's cooking area.
- Release material coating is worn off sheet.

NORMAL OPERATION

Installing Release Material:

For installation instructions, see section on RELEASE MATERIAL INSTALLATION.

A release material sheet must be replaced when:

- Product sticks to release material.
- Carbon build-up ruins taste or appearance.
- Tearing occurs in the sheet's cooking area.
- Release material coating is worn off sheet.

Lighting Instructions:



1. Ensure that the flexible gas hose is connected to the grill and the power cord is plugged into the receptacles.
2. Turn the main power switch ON and allow the controls to go through the power-up self-check. Once the control panel displays the word "OFF" the unit is ready to begin the heating process.
3. Press . The control will automatically initiate the heating cycle. The burner will ignite and heat until the temperature specified by the menu item has been obtained.

If ignition of the burner does not occur on the first trial, the bottom indicator light will flash amber. If the burner(s) do not light within four trials for ignition, the control will display a flashing warning, "IGNITION ERROR." The flashing amber light will turn to solid red and an audible alarm will sound. If this occurs, turn the main power switch off, wait 5 minutes, and then repeat steps 2 and 3. If after 2nd try and the control still produces the IGNITION ERROR refer to Ignition failure in TECHNICAL TROUBLE SHOOTING section.

Shut Down Instructions

1. To shut down the unit at any time, switch the main power switch to the off (non-lit) position.
2. For extended shut down periods, switch the main power switch to the off position, disconnect the unit from the gas supply line and unplug electrical connections.

To Cook in Two-Sided Mode:

1. To start a cook cycle select a product recipe by using the product keys (1 through 9) or by using the UP/DOWN keys  or  to select a product recipe.



The display alternately blinks the recipe and the word SELECTED 2 times then the recipe displays continuously.

2. The controller regulates the platen and grill temperatures to the set temperatures of the product selected and reads "TOO COOL" or "TOO HOT" with "MENU ITEM", until the grill attains the set temperature range for the item.

NOTE: If the display reads either "TOO COOL" or "TOO HOT" the upper platen will not lower and initiate a cooking sequence.

3. After loading the product onto the grill, press the green CANCEL/RAISE PLATEN BUTTON and BLACK button simultaneously. A cook cycle starts and the upper platen lowers if the product selected is clamshell recipe.
4. To cancel a cook cycle at anytime press the green CANCEL/RAISE PLATEN BUTTON and the upper platen will rise if the product recipe selected is clamshell recipe.
5. During a cook cycle, the display shows the product recipe name in the first line and the remaining cook time count down in the second line.
6. When the cook timer reaches one, (1), second remaining a pre-time-out alarm sounds alerting the operator.
7. When the cooking time has been completed the platen raises automatically. On the controller the "PRODUCT NAME" and the word "REMOVE" will be displayed and an audible alert will sound.
8. Pressing the green CANCEL/RAISE PLATEN BUTTON stops the audible alert and the unit will revert back to IDLE mode.

To Cook in Flat Grill Mode:

1. To start a cook cycle select a product recipe by using the product keys (1 through 9) or by using the UP/DOWN keys  or  to select a product recipe.

The display alternately blinks the recipe and the word SELECTED 2 times then the recipe will be displayed continuously.

2. The controller regulates the grill temperature to the set temperature of the product selected and reads "TOO COOL" or "TOO HOT" with "MENU ITEM", until the grill attains the set temperature range for the item.

NOTE: If the display reads either "TOO COOL" or "TOO HOT" it will not initiate a cooking sequence.



3. After loading the product onto the grill, press the green CANCEL/RAISE PLATEN BUTTON and BLACK button simultaneously. That will start a cook cycle if the product selected is clamshell recipe.

NORMAL OPERATION *continued*

- To cancel a cook cycle at anytime the press the green CANCEL/RAISE PLATEN BUTTON .
- During a cook cycle, the display shows the product recipe name in the first line and the remaining cook time count down in the second line.
- The display shows the "SEAR" or "FLIP" alarm message with flashing in the second line if the current cooking product is flat recipe and the sear time or flip time is not zero.
- A cook alarm sounds with a repeating beep pattern. Pressing the black RAISE button acknowledges the "SEAR" or "FLIP" alarm message if the alarm field in system setup is set to MANUAL.
- The "SEAR" or "FLIP" alarm message stops after 5 seconds if the alarm field in system setup is set to AUTO.
- When a cook is complete, the display shows the product recipe name in the first line and a flashing "REMOVE" message in the second line. A repeating beeping alarm also sounds.
- Pressing the black RAISE button cancels the cook done alarm.
- The unit reverts back to IDLE mode.

Enter Standby Mode:

Stand by mode is used during slow periods to conserve energy with out a complete shut down of the unit. When cooking temperatures are again required, pre-heat cook temperature/time is reduced. Stand by mode temperatures can be adjusted, see the PROGRAMING section.

- Select Standby Mode by pressing  or  until "STANDBY" is displayed.
- Press the GREEN ('CANCEL/RAISE') and the BLACK buttons at the same time. As soon as the upper platen moves down, the display will read "STANDBY MODE." (Note: The first time Standby Mode is entered, the display will prompt the operator to press ENTER after pressing the GREEN and BLACK buttons.)

Exit Standby Mode:

- Press the GREEN ('CANCEL/RAISE') button. The upper platen will raise and the display will read "CANCEL" with an audible alarm.

To Display the Current Temperatures:





- Press the  button and repeat for each zone to be displayed...

1st press - LOWER GRILL ZONE





2nd press - UPPER PLATEN

NOTE: The temperatures may be displayed at any time, including during a cooking cycle.

To View Settings for a Menu Item:

- Enter Programming; Menu Items, (see Programming)
- Press  to enter "PROGRAMMING MODE MENU ITEMS"
- Use  and  to choose the desired Menu Item.
- Press  to scroll through settings for the chosen item.

To Clean the Grill:

- To start a CLEAN MODE select the clean mode recipe by pressing product key 10 or by using the UP/DOWN keys  or  to select the clean mode recipe.
- The controller regulates the platen and grill temperatures to the set temperatures of the clean mode recipe. The display shows the message "CLEAN MODE" in the first line and the actual grill temperature in the second line.
- Press the ENTER key  to initiate the clean mode.
- The display SHOWS the message "READY TO CLEAN" with flashing in the second line when the actual temperature is reached (or greater than the set temperatures of clean mode recipe (default 250 F for both the platen and grill)). A 5 second repeating beep pattern is sounded.
- Press the ENTER key  again, the heater's control for the platen and grill are turned off and the display shows the message "CLEANING" with flashing in the second line.
- Press the ENTER key again to exit the CLEAN MODE. The display shows the message "STANDBY" in the first line. The control transitions to "STANDBY MODE" and preheats to idle condition.

PLATEN SET:

This function allows the platen to be moved up or down once it is parallel to the grill surface. Values range from -160 to +160.

NORMAL OPERATION *continued*



EXTENDED TIME:

This option will add 6, 4 and 2 seconds to the time of the next three cooks respectively if the grill has had no activity for 5 minutes. Provided the temperature is not 25°F above set temperature for either the grill or the platen.

INSTANT ON TIME:

This can be set in the range of 00:00 to 00:40. Instant on will turn on the heat zone(s) as soon as a cook cycle starts.

START DELAY:

This number is how long the operator must hold the GREEN ('CANCEL/RAISE') and BLACK buttons to start a cooking cycle for 2-sided recipes only. There will be one beep when the cook is started and another beep when the START DELAY time is reached. If the GREEN ('CANCEL/RAISE') and BLACK buttons are released before that time the cook will be canceled. If Yes is toggled press enter to allow the user to pick from 1 to 5 seconds in 0.5 second increments using  and .

CLEANING AND MAINTENANCE

Tools: JIB Hi-Temp Grill Cleaner (HCS), JIB All Purpose Super Concentrate (HCS), JIB NO-SCRATCH (Pad and Pad Holder), a suitable container, High-Temperature Pan Brush and Grill Cloth, Stainless Steel Pan filled with lukewarm water, Protective Gloves,, (to protect hands from heat), Grill Squeegee and Grill Scraper.

Warning: The upper platen surface and edges are very hot! To prevent burn injuries, use extreme caution when wiping down release sheets and platen edges.

Important: Frequently throughout the day, (at least 4 times per hour), thoroughly wipe down the release sheets and platen edges with a damp grill cloth.





Cleaning During Operation:

1. After each product load is removed, Use a grill scraper to scrape grease on lower grill plate from front to back only. Do not scrape left to right across the lower grill plate with the grill scraper.
2. Use a grill squeegee to clean release material sheet on upper platen in a downward motion. Do not press hard against the release material sheet to prevent scratching or tearing.
3. Push the grease to the rear of the grill, or pull it to the front trough. Then, squeegee the grease into the buckets on either side. Do not use the scraper for this step.
4. Use a clean, damp cloth to clean back splash and bullnose areas as needed during operation.

Note: To increase life of release material sheets, wipe them down with a folded clean, damp cloth at least four times during each hour of operation.

Daily Cleaning:

Warning: The upper platen surface and edges are very hot! To prevent burn injuries, use extreme caution when wiping down release sheets and platen edges.

1. Press the CLEAN button, or  or  to obtain the menu item "CLEAN MODE."
2. Press  to acknowledge that Clean Mode is desired. This will cause the appliance (grill and platen, if selected) to heat to the Clean Temperature.
3. "READY TO CLEAN" will be displayed when the grill is at the proper cleaning temperature and an audible alarm will sound.
4. To exit Clean Mode, press . Display will show "OFF."
5. Wearing protective gloves, empty and replace the grease troughs.
6. Wipe down the exposed surface of the release sheet with a clean, damp cloth.

Note: the edge of the grill above the grease troughs gets a build up of grease, wipe down every time the grease bucket is emptied. CAUTION this edge is hot.

7. Remove the release sheet locking clips and bars.
8. Scrape only the lower grill surface with a grill scraper, and squeegee any residue into the grease troughs with a grill squeegee.

Caution: Do not scrape or otherwise scratch the upper platens. The use of metal scrapers, abrasive pads, or wire brushes will permanently damage the surface of the upper platens.

CLEANING AND MAINTENANCE *continued*

9. Open one packet of high-temperature grill cleaner, (several cleaners may be available on the market), and empty the contents into a suitable container. (One packet will clean one grill.)
10. Firmly attach a no-scratch pad to a pad holder.
11. Dip the no-scratch pad into the grill cleaner, and spread a light coating of grill cleaner over the entire platen surface, back, front, and side edges of both upper platens. **DO NOT SCRUB.** (Note: use very limited cleaning solution on top of platens)
12. After applying the grill cleaner, lightly scrub the platen surface, and all four edges with the no-scratch pad until all the soil has been liquefied by the grill cleaner. For stubborn soils, apply additional grill cleaner and lightly scrub. **DO NOT RINSE THE PLATENS AT THIS TIME.**
13. Starting at the back of the lower grill, spread a light coating of grill cleaner over the surface. **DO NOT SCRUB.**
14. After applying the grill cleaner, lightly scrub the grill surface with the No-Scratch Pad until all the soil has been liquefied.
15. Rinse the upper platens with a dripping wet cloth. Do not use excessive water on the top of the platens.
16. Carefully pour small quantities of lukewarm water onto the grill while brushing the surface, backsplash, and bullnose with a pot brush or equivalent high-temperature brush. Continue until the water no longer boils away and the grill remains wet. Squeegee dry.

Caution: Ice, cold water, or large quantities of water must never be applied to the grill plate or upper platen. Severe damage to the grill will occur!

17. Clean the release sheets as follows:
 - A) Place the sheets on the lower grill. Scrub both sides of the sheets with the same no-scratch pad used on the grill.
 - B) Rinse both sides of the sheets with a clean, wet cloth.
18. Rinse the lower grill by flooding the surface twice with lukewarm water. Squeegee after each rinse.
19. Wipe the lower grill surface, backsplash, bullnose, and hood with a clean, damp cloth.
20. When cleaning is completed, you may turn the "MASTER POWER" (rocker) switch off.

AFTER CLEANING, apply a thin coat of fresh shortening to the lower grill surface only. Wipe down the surrounding areas. Empty, wash, rinse, and replace the grease troughs.

PROGRAMMING

Programming Modes/Menu Sequence:

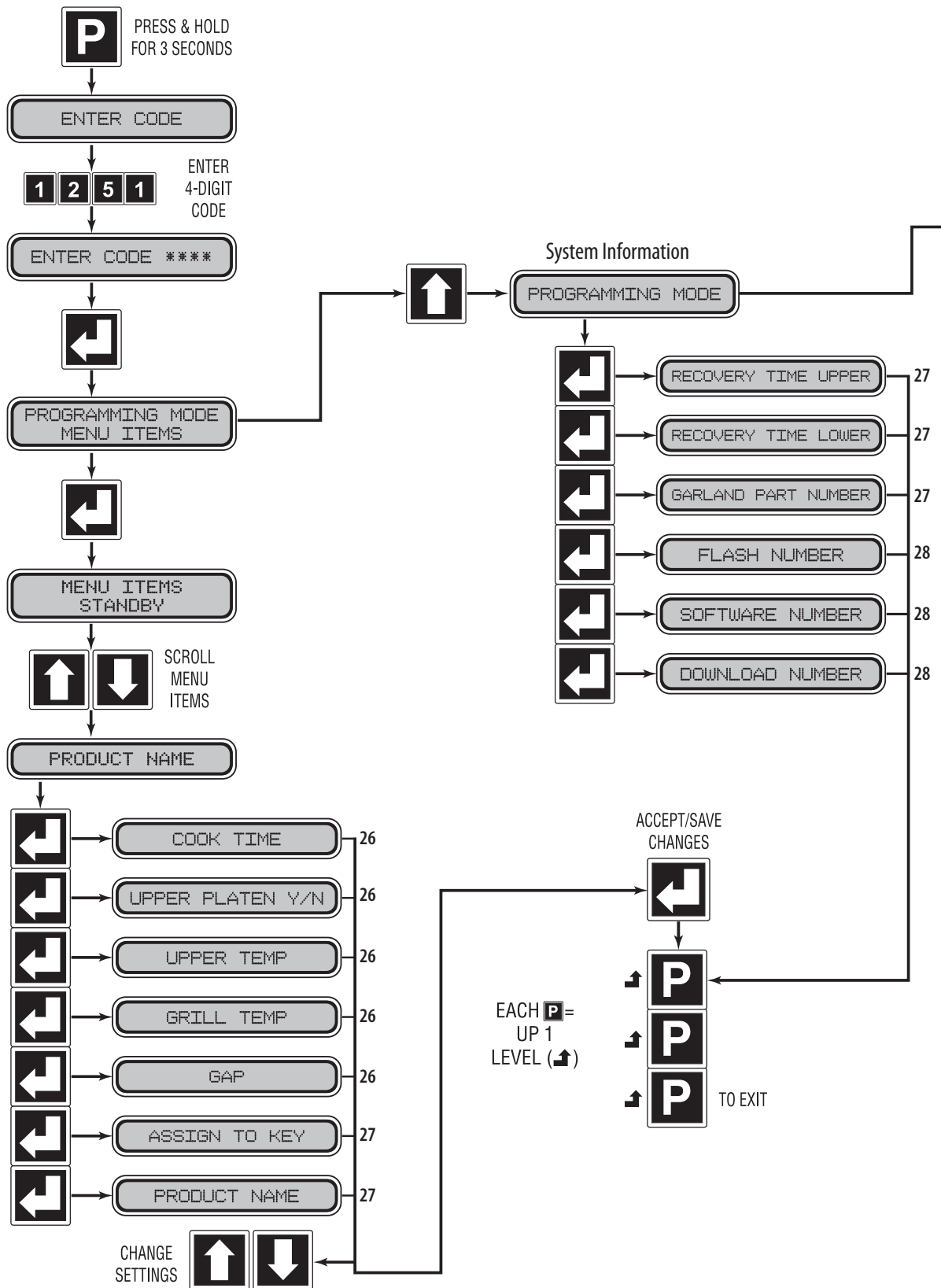

PROGRAMMING *continued*



Press Once



Press Multiple



Display

XX = See Page XX for detailed instructions.

System Set-up

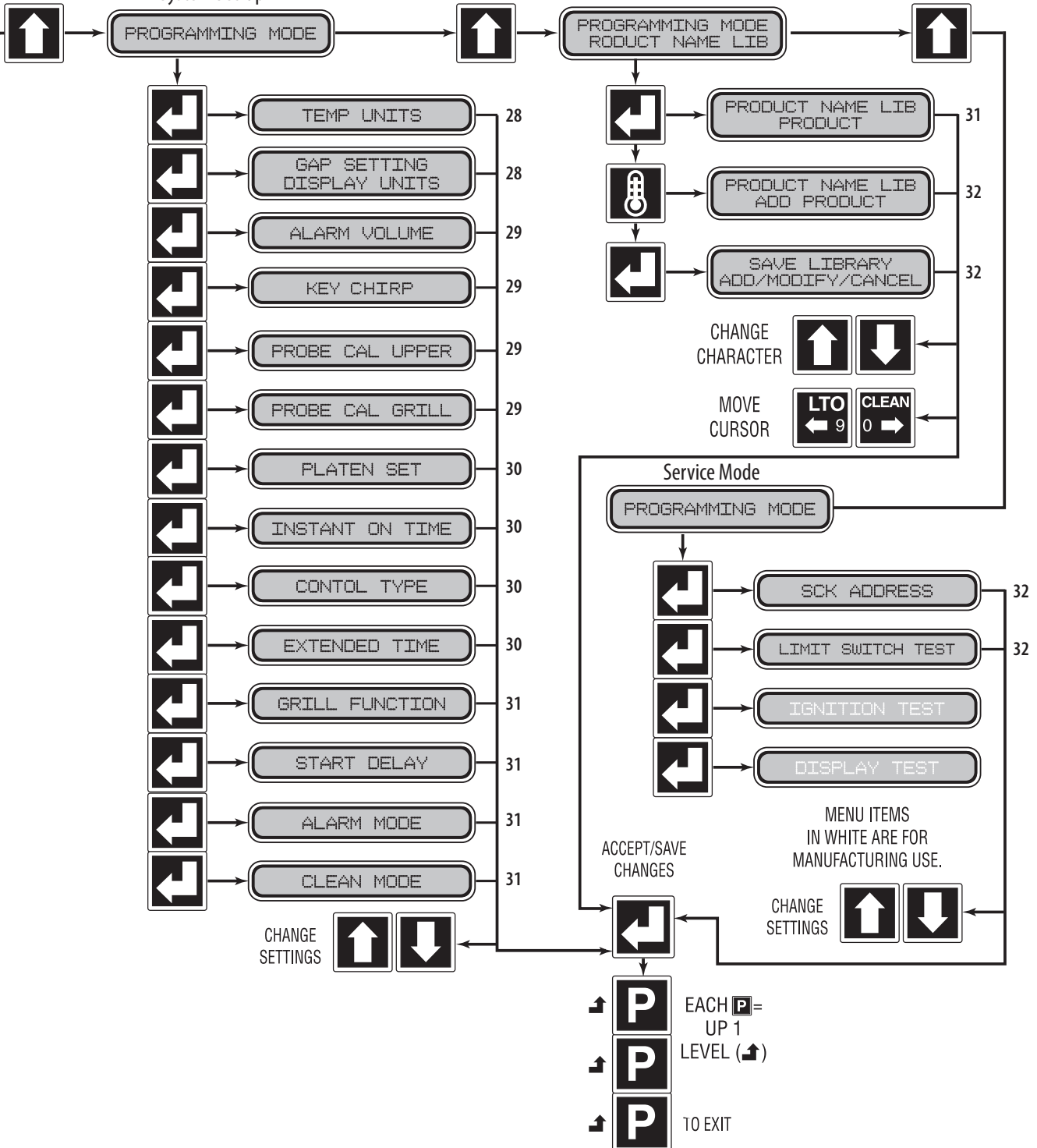

Menu Items...

To Change the Cook Time of a Product:

1. Press and hold **P** for three, (3) seconds. "ENTER CODE" is displayed.
2. Using the Product buttons, 0-9 enter the code, (1251). "ENTER CODE ****" is displayed.
3. Press **□** to enter Programming Mode. "PROGRAMMING MODE MENU ITEMS" is displayed.
4. Press **□**. "MENU ITEMS STANDBY" is displayed.
5. Use **↑** and **↓** to choose the desired Menu Item.
6. Press **□** to display "(MENU ITEM) COOK TIME XX:XX"
7. Use **↑** and **↓** to adjust the cook time.
8. Press **□** to save the changes.
9. Press **P** twice to exit.

To Turn Platen, (2-Sided), Cooking On/Off:

1. Press and hold **P** for three, (3) seconds. "ENTER CODE" is displayed.
2. Using the Product buttons, 0-9 enter the code, (1251). "ENTER CODE ****" is displayed.
3. Press **□** to enter the Programming Mode. "PROGRAMMING MODE MENU ITEMS" is displayed.
4. Press **□**. "MENU ITEMS STANDBY" is displayed.
5. Use **↑** and **↓** to choose the desired Menu Item.
6. Press **□** twice to display "(MENU ITEM) UPPER PLATEN YES/NO".
7. Use **↑** and **↓** to turn upper platen on or off.
8. Press **□** to save the changes.
9. Press **P** twice to exit.

To Change Upper Platen Set Temperature:

1. Press and hold **P** for three, (3) seconds. "ENTER CODE" is displayed.
2. Using the Product buttons, 0-9 enter the code, (1251). "ENTER CODE ****" is displayed.
3. Press **□** to enter the Programming Mode. "PROGRAMMING MODE MENU ITEMS" is displayed.
4. Press **□**. "MENU ITEMS STANDBY" is displayed.

5. Use **↑** and **↓** to choose the desired Menu Item.
6. Press **□** three, (3) times to display "(MENU ITEM) UPPER TEMP XXX" displayed in °F or °C.
7. Use **↑** and **↓** to change the set temperature to the desired value.
8. Press **□** to save the changes.
9. Press **P** twice to exit.

To Change Grill Set Temperature:

1. Press and hold **P** for three, (3) seconds. "ENTER CODE" is displayed.
2. Using the Product buttons, 0-9 enter the code, (1251). "ENTER CODE ****" is displayed.
3. Press **□** to enter the Programming Mode. "PROGRAMMING MODE MENU ITEMS" is displayed.
4. Press **□**. "MENU ITEMS STANDBY" is displayed.
5. Use **↑** and **↓** to choose the desired Menu Item.
6. Press **□** four, (4) times to display "(MENU ITEM) GRILL TEMP XXX" displayed in °F or °C.
7. Use **↑** and **↓** to change the set temperature to the desired value.
8. Press **□** to save the changes.
9. Press **P** twice to exit.

To Change Product Gap Setting:

1. Press and hold **P** for three, (3) seconds. "ENTER CODE" is displayed.
2. Using the Product buttons, 0-9 enter the code, (1251). "ENTER CODE ****" is displayed.
3. Press **□** to enter the Programming Mode. "PROGRAMMING MODE MENU ITEMS" is displayed.
4. Press **□**. "MENU ITEMS STANDBY" is displayed.
5. Use **↑** and **↓** to choose the desired Menu Item.
6. Press **□** five, (5) times to display "GAP XXX" displayed in inches or mm.
7. Use **↑** and **↓** to change the gap setting to the desired value.
8. Press **□** to save the changes.
9. Press **P** twice to exit.

To Change Product Button, "Key" Assignment

1. Press and hold **P** for three, (3) seconds. "ENTER CODE" is displayed.
2. Using the Product buttons, 0-9 enter the code, (1251). "ENTER CODE ****" is displayed.
3. Press **↵** to enter the Programming Mode. "PROGRAMMING MODE MENU ITEMS" is displayed.
4. Press **↵**. "MENU ITEMS STANDBY" is displayed.
5. Use **↑** and **↓** to choose the desired Menu Item.
6. Press **↵** six, (6) times to display "ASSIGN TO KEY (0-9 or NONE)".
7. Use **↑** and **↓** to change the key, (Product Button), assignment, and replace any previous assignments to that key.
8. Press **↵** to save the changes.
9. Press **P** twice to exit.

To Change a Product Name:

1. Press and hold **P** for three, (3) seconds. "ENTER CODE" is displayed.
2. Using the Product buttons, 0-9 enter the code, (1251). "ENTER CODE ****" is displayed.
3. Press **↵** to enter the Programming Mode. "PROGRAMMING MODE MENU ITEMS" is displayed.
4. Press **↵**. "MENU ITEMS STANDBY" is displayed.
5. Use **↑** and **↓** to choose the desired Menu Item.
6. Press **↵** seven, (7) times to display "PRODUCT NAME (CHOSEN ITEM)".
7. Use **↑** and **↓** to cycle through the available product names until the desired name is achieved.
8. Press **↵** to save the changes. You will automatically return to "PROGRAMMING MODE MENU ITEMS".
9. Press **P** to exit.

System Info...

To View Recovery Time - Upper Platen:

1. Press and hold **P** for three, (3) seconds. "ENTER CODE" is displayed.
2. Using the Product buttons, 0-9 enter the code, (1251). "ENTER CODE ****" is displayed.

3. Press **↵** to enter the Programming Mode. "PROGRAMMING MODE MENU ITEMS" is displayed.
4. Press **↑** one, (1) time to display "PROGRAMMING MODE SYSTEM INFO."
5. Press **↵** to view the upper recovery time. "RECOVERY UPPER XXXX" is displayed.
6. Press **P** to return to "PROGRAMMING MODE SYSTEM INFO".
7. Press **P** to exit.

To View Recovery Time - Grill:

1. Press and hold **P** for three, (3) seconds. "ENTER CODE" is displayed.
2. Using the Product buttons, 0-9 enter the code, (1251). "ENTER CODE ****" is displayed.
3. Press **↵** to enter the Programming Mode. "PROGRAMMING MODE MENU ITEMS" is displayed.
4. Press **↑** one, (1) time to display "PROGRAMMING MODE SYSTEM INFO."
5. Press **↵** two, (2), times to view the grill recovery time. "RECOVERY GRILL XXXX" is displayed.
6. Press **P** to return to "PROGRAMMING MODE SYSTEM INFO".
7. Press **P** to exit.

To View the Garland Part Number:

1. Press and hold **P** for three, (3) seconds. "ENTER CODE" is displayed.
2. Using the Product buttons, 0-9 enter the code, (1251). "ENTER CODE ****" is displayed.
3. Press **↵** to enter the Programming Mode. "PROGRAMMING MODE MENU ITEMS" is displayed.
4. Press **↑** one, (1) time to display "PROGRAMMING MODE SYSTEM INFO."
5. Press **↵** three, (3), times to view the Garland Part Number for the grill. "GARLAND PART # X...X" is displayed. (number varies by grill).
6. Press **P** to return to "PROGRAMMING MODE SYSTEM INFO".
7. Press **P** to exit.

To View the Flash Number:

1. Press and hold **P** for three, (3) seconds. "ENTER CODE" is displayed.
2. Using the Product buttons, 0-9 enter the code, (1251). "ENTER CODE ****" is displayed.
3. Press **↵** to enter the Programming Mode. "PROGRAMMING MODE MENU ITEMS" is displayed.
4. Press **↑** one, (1) time to display "PROGRAMMING MODE SYSTEM INFO."
5. Press **↵** four, (4), times to view the Flash Number. "FLASH NUMBER X...X" is displayed. (Flash number varies by grill).
6. Press **P** to return to "PROGRAMMING MODE SYSTEM INFO".
7. Press **P** to exit.

To View the Software Number:

1. Press and hold **P** for three, (3) seconds. "ENTER CODE" is displayed.
2. Using the Product buttons, 0-9 enter the code, (1251). "ENTER CODE ****" is displayed.
3. Press **↵** to enter the Programming Mode. "PROGRAMMING MODE MENU ITEMS" is displayed.
4. Press **↑** one, (1) time to display "PROGRAMMING MODE SYSTEM INFO."
5. Press **↵** five, (5), times to view the Software Number. "SOFTWARE NUMBER X...X" is displayed. (number varies by grill).
6. Press **P** to return to "PROGRAMMING MODE SYSTEM INFO".
7. Press **P** to exit.

To View the Download Number:

1. Press and hold **P** for three, (3) seconds. "ENTER CODE" is displayed.
2. Using the Product buttons, 0-9 enter the code, (1251). "ENTER CODE ****" is displayed.
3. Press **↵** to enter the Programming Mode. "PROGRAMMING MODE MENU ITEMS" is displayed.
4. Press **↑** one, (1) time to display "PROGRAMMING MODE SYSTEM INFO."

5. Press **↵** six, (6), times to view the Download Number. "DOWNLOAD NUMBER X...X" is displayed. (Download number varies by grill).
6. Press **P** to return to "PROGRAMMING MODE SYSTEM INFO".
7. Press **P** to exit.

System Setup

To Change temperature Units, (°F or °C):

1. Press and hold **P** for three, (3) seconds. "ENTER CODE" is displayed.
2. Using the Product buttons, 0-9 enter the code, (1251). "ENTER CODE ****" is displayed.
3. Press **↵** to enter the Programming Mode. "PROGRAMMING MODE MENU ITEMS" is displayed.
4. Press **↑** two, (2) times. "PROGRAMMING MODE SYSTEM SETUP" is displayed.
5. Press **↵** to enter system setup. "TEMP DISPLAY FAHRENHEIT (or CELSIUS)" is displayed.
6. Press **↓** to change the temperature units to either Fahrenheit or Celsius.
7. Press **↵** to save the changes.
8. Press **P** to return to "PROGRAMMING MODE SYSTEM SETUP".
9. Press **P** again to exit.

To Change Gap Setting Display Units:

1. Press and hold **P** for three, (3) seconds. "ENTER CODE" is displayed.
2. Using the Product buttons, 0-9 enter the code, (1251). "ENTER CODE ****" is displayed.
3. Press **↵** to enter the Programming Mode. "PROGRAMMING MODE MENU ITEMS" is displayed.
4. Press **↑** two, (2) times. "PROGRAMMING MODE SYSTEM SETUP" is displayed.
5. Press **↵** two, (2), times. "GAP SETTING DISPLAY INCHES (or MILLIMETERS)" is displayed.
6. Press **↓** to change the Gap Setting Display units to either Inches or Millimeters.
7. Press **↵** to save the changes.

8. Press **P** to return to "PROGRAMMING MODE SYSTEM SETUP"
9. Press **P** again to exit.

To Change the Alarm Volume:

1. Press and hold **P** for three, (3) seconds. "ENTER CODE" is displayed.
2. Using the Product buttons, 0-9 enter the code, (1251). "ENTER CODE ****" is displayed.
3. Press **↵** to enter the Programming Mode. "PROGRAMMING MODE MENU ITEMS" is displayed.
4. Press **↑** two, (2) times. "PROGRAMMING MODE SYSTEM SETUP" is displayed.
5. Press **↵** three, (3), times. "ALARM VOLUME LOW (or HIGH)" is displayed.
6. Use **↑** or **↓** to change the Alarm Volume to either Low or High.
7. Press **↵** to save the changes.
8. Press **P** to return to "PROGRAMMING MODE SYSTEM SETUP"
9. Press **P** again to exit.

To Change the Key Chirp:

To turn key chirp on or off in programing mode only.

1. Press and hold **P** for three, (3) seconds. "ENTER CODE" is displayed.
2. Using the Product buttons, 0-9 enter the code, (1251). "ENTER CODE ****" is displayed.
3. Press **↵** to enter the Programming Mode. "PROGRAMMING MODE MENU ITEMS" is displayed.
4. Press **↑** two, (2) times. "PROGRAMMING MODE SYSTEM SETUP" is displayed.
5. Press **↵** four, (4), times. "KEY CHIRP ON (or OFF)" is displayed.
6. Use **↑** or **↓** to change the key chirp to either ON or OFF.
7. Press **↵** to save the changes.
8. Press **P** to return to "PROGRAMMING MODE SYSTEM SETUP"
9. Press **P** again to exit.

To Change Probe Calibration - Upper:

1. Press and hold **P** for three, (3) seconds. "ENTER CODE" is displayed.
2. Using the Product buttons, 0-9 enter the code, (1251). "ENTER CODE ****" is displayed.
3. Press **↵** to enter the Programming Mode. "PROGRAMMING MODE MENU ITEMS" is displayed.
4. Press **↑** two, (2) times. "PROGRAMMING MODE SYSTEM SETUP" is displayed.
5. Press **↵** five, (5), times. "PROBE CAL – UPPER XXXF" is displayed.
6. Use **↑** or **↓** to change the Probe Calibration to the correct temperature measured with a pyrometer.* SEE CALIBRATION REQUIREMENTS and CALIBRATION section.
7. Press **↵** to save the changes.
8. Press **P** to return to "PROGRAMMING MODE SYSTEM SETUP"
9. Press **P** again to exit.

To Change Probe Calibration - Grill:

1. Press and hold **P** for three, (3) seconds. "ENTER CODE" is displayed.
2. Using the Product buttons, 0-9 enter the code, (1251). "ENTER CODE ****" is displayed.
3. Press **↵** to enter the Programming Mode. "PROGRAMMING MODE MENU ITEMS" is displayed.
4. Press **↑** two, (2) times. "PROGRAMMING MODE SYSTEM SETUP" is displayed.
5. Press **↵** six, (6), times. "PROBE CAL – GRILL XXXF" is displayed.
6. Use **↑** or **↓** to change the Probe Calibration to the correct temperature measured with a pyrometer.* SEE CALIBRATION REQUIREMENTS and CALIBRATION Section.
7. Press **↵** to save the changes.
8. Press **P** to return to "PROGRAMMING MODE SYSTEM SETUP"
9. Press **P** again to exit.

*CALIBRATION REQUIREMENTS

The control software will beep to the user when it is appropriate to calibrate. The control will allow calibration provided the following conditions are met:

PROGRAMMING *continued*

- Temperature is currently falling from a detected peak of 360°F or higher.
- Temperature is falling and has fallen 2°F from a detected peak that is within the 350-360°F range. (i.e. calibration would be allowed at 355°F if the achieved peak temperature was 357°F)
- Temperature is rising through the 350-360°F range as a result of a heat on pulse of less than 30 seconds.

To Change Platen Set:

1. Press and hold **P** for three, (3) seconds. "ENTER CODE" is displayed.
2. Using the Product buttons, 0-9 enter the code, (1251). "ENTER CODE ****" is displayed.
3. Press **↵** to enter the Programming Mode. "PROGRAMMING MODE MENU ITEMS" is displayed.
4. Press **↑** two, (2) times. "PROGRAMMING MODE SYSTEM SETUP" is displayed.
5. Press **↵** seven, (7) times. "PLATEN SET +/- XX" is displayed. (numbers will vary by grill)
6. Use **↑** and **↓** to change the Platen Set to the correct value.
7. Press **↵** to save the changes.
8. Press **P** to return to "PROGRAMMING MODE MENU ITEMS"
9. Press **P** again to exit.

To Change Instant-On Time:

1. Press and hold **P** for three, (3) seconds. "ENTER CODE" is displayed.
2. Using the Product buttons, 0-9 enter the code, (1251). "ENTER CODE ****" is displayed.
3. Press **↵** to enter the Programming Mode. "PROGRAMMING MODE MENU ITEMS" is displayed.
4. Press **↑** two, (2) times. "PROGRAMMING MODE SYSTEM SETUP" is displayed.
5. Press **↵** eight, (8) times. "INSTANT ON TIME XX:XX" is displayed. (numbers will vary by grill).
6. Use **↑** and **↓** to change the Instant on Time to the desired value.
7. Press **↵** to save the changes.
8. Press **P** to return to "PROGRAMMING MODE MENU ITEMS"

9. Press **P** again to exit.

To Change Control Type:

Note: this must be verified if the control is changed, match the new control to the grill.

1. Press and hold **P** for three, (3) seconds. "ENTER CODE" is displayed.
2. Using the Product buttons, 0-9 enter the code, (1251). "ENTER CODE ****" is displayed.
3. Press **↵** to enter the Programming Mode. "PROGRAMMING MODE MENU ITEMS" is displayed.
4. Press **↑** two, (2) times. "PROGRAMMING MODE SYSTEM SETUP" is displayed.
5. Press **↵** nine, (9) times. "CONTROL TYPE ELECTRIC (or GAS)" is displayed. (type varies by grill).
6. Use **↑** and **↓** to change Control Type to match the design of the grill.
7. Press **↵** to save the changes.
8. Press **P** to return to "PROGRAMMING MODE MENU ITEMS"
9. Press **P** again to exit.

To Turn Extended Time On/Off:

1. Press and hold **P** for three, (3) seconds. "ENTER CODE" is displayed.
2. Using the Product buttons, 0-9 enter the code, (1251). "ENTER CODE ****" is displayed.
3. Press **↵** to enter the Programming Mode. "PROGRAMMING MODE MENU ITEMS" is displayed.
4. Press **↑** two, (2) times. "PROGRAMMING MODE SYSTEM SETUP" is displayed.
5. Press **↵** ten, (10) times. "EXTENDED TIME NO (or YES)" is displayed.
6. Use **↑** and **↓** to turn Extended Time on or off.
7. Press **↵** to save the changes.
8. Press **P** to return to "PROGRAMMING MODE MENU ITEMS"
9. Press **P** again to exit.

To Change the Grill Function:

1. Press and hold **P** for three, (3) seconds. "ENTER CODE" is displayed.
2. Using the Product buttons, 0-9 enter the code, (1251). "ENTER CODE ****" is displayed.
3. Press **↵** to enter the Programming Mode. "PROGRAMMING MODE MENU ITEMS" is displayed.
4. Press **↑** two, (2) times. "PROGRAMMING MODE SYSTEM SETUP" is displayed.
5. Press **↵** eleven, (11) times. "FUNCTION CLAMSHELL (or FLAT)" is displayed.
6. Use **↑** and **↓** to toggle between Flat mode and Clamshell mode.
7. Press **↵** to save the changes.
8. Press **P** to return to "PROGRAMMING MODE MENU ITEMS"
9. Press **P** again to exit.

To Change the Start Delay:

1. Press and hold **P** for three, (3) seconds. "ENTER CODE" is displayed.
2. Using the Product buttons, 0-9 enter the code, (1251). "ENTER CODE ****" is displayed.
3. Press **↵** to enter the Programming Mode. "PROGRAMMING MODE MENU ITEMS" is displayed.
4. Press **↑** two, (2) times. "PROGRAMMING MODE SYSTEM SETUP" is displayed.
5. Press **↵** twelve, (12) times. "START DELAY YES (or NO)" is displayed.
6. Use **↑** and **↓** to turn Start Delay on or off.
7. If Start Delay is On (YES), press **↵** to display "DELAY TIME XX:XX".
8. Use **↑** and **↓** to set the Delay Time to the desired value.
9. Press **↵** to save the changes.
10. Press **P** to return to "PROGRAMMING MODE MENU ITEMS"
11. Press **P** again to exit.

To Change the Alarm Mode:

1. Press and hold **P** for three, (3) seconds. "ENTER CODE" is displayed.
2. Using the Product buttons, 0-9 enter the code, (1251). "ENTER CODE ****" is displayed.
3. Press **↵** to enter the Programming Mode. "PROGRAMMING MODE MENU ITEMS" is displayed.
4. Press **↑** two, (2) times. "PROGRAMMING MODE SYSTEM SETUP" is displayed.
5. Press **↵** thirteen, (13) times. "ALARM MODE AUTO (or MANUAL)" is displayed.
6. Use **↑** and **↓** to change the Alarm Mode to either Auto or Manual.
7. Press **↵** to save the changes.
8. Press **P** to return to "PROGRAMMING MODE MENU ITEMS"
9. Press **P** again to exit.

To Turn Clean Mode On/Off:

1. Press and hold **P** for three, (3) seconds. "ENTER CODE" is displayed.
2. Using the Product buttons, 0-9 enter the code, (1251). "ENTER CODE ****" is displayed.
3. Press **↵** to enter the Programming Mode. "PROGRAMMING MODE MENU ITEMS" is displayed.
4. Press **↑** two, (2) times. "PROGRAMMING MODE SYSTEM SETUP" is displayed.
5. Press **↵** fourteen, (14) times. "CLEAN MODE YES (or NO)" is displayed.
6. Use **↑** and **↓** to turn Clean Mode On or Off.
7. Press **↵** to save the changes.
8. Press **P** to return to "PROGRAMMING MODE MENU ITEMS"
9. Press **P** again to exit.

To Add a Product Name in Library:

1. Press and hold **P** for three, (3) seconds. "ENTER CODE" is displayed.
2. Using the Product buttons, 0-9 enter the code, (1251). "ENTER CODE ****" is displayed.

PROGRAMMING *continued*

3. Press to enter the Programming Mode.
"PROGRAMMING MODE MENU ITEMS" is displayed.
4. Press three, (3) times. "PROGRAMMING MODE PROD NAME LIB" is displayed.
5. Press . "PROD NAME LIB" is displayed.
6. Press . "PROD NAME LIB" will be displayed on the top line, with a flashing cursor on the bottom line.
7. Use and to change the character, (A-Z, 1-9, <space>, and hyphen are available). Use and to move the cursor position.
8. Press to save the new product name. "SAVE LIBRARY ADD" is displayed.
9. Press to save. "PROGRAMMING MODE PROD NAME LIB" is displayed.
10. Press to exit.

To Modify a Product Name in Library:

1. Press and hold for three, (3) seconds. "ENTER CODE" is displayed.
2. Using the Product buttons, 0-9 enter the code, (1251).
"ENTER CODE ****" is displayed.
3. Press to enter the Programming Mode.
"PROGRAMMING MODE MENU ITEMS" is displayed.
4. Press three, (3) times. "PROGRAMMING MODE PROD NAME LIB" is displayed.
5. Press . "PROD NAME LIB" is displayed.
6. Use and to select Product Name to be modified.
7. Press . The first character in the Product Name will start flashing.
8. Use and to change the character, (A-Z, 1-9, <space>, and hyphen are available). Use and to move the cursor position.
9. Press . "SAVE LIBRARY ADD" is displayed.
10. Press . "SAVE LIBRARY MODIFY" is displayed.
11. Press to save. "PROGRAMMING MODE PROD NAME LIB" is displayed.
12. Press to exit.

Service Mode

To Change SCK Address:

1. Press and hold for three, (3) seconds. "ENTER CODE" is displayed.
2. Using the Product buttons, 0-9 enter the code, (1251).
"ENTER CODE ****" is displayed.
3. Press to enter the Programming Mode.
"PROGRAMMING MODE MENU ITEMS" is displayed.
4. Press three, (3) times. "PROGRAMMING MODE SERVICE MODE" is displayed.
5. Press one, (1), time. "Address XX" is displayed.
6. Use and to change to the desired SCK Address.
7. Press to save the changes.
8. Press to return to "PROGRAMMING MODE SERVICE MODE"
9. Press again to exit.

To Perform Limit Switch Test:

1. Press and hold for three, (3) seconds. "ENTER CODE" is displayed.
 2. Using the Product buttons, 0-9 enter the code, (1251).
"ENTER CODE ****" is displayed.
 3. Press to enter the Programming Mode.
"PROGRAMMING MODE MENU ITEMS" is displayed.
 4. Press three, (3) times. "PROGRAMMING MODE SERVICE MODE" is displayed.
 5. Press two, (2), times. "PLATEN" (along with the position of each switch), is displayed.
 6. Use and to move the platen up and down. Check for correct switch operation:
- Correct Switch Operation:**
- Platen Up** - U (Closed) L (Open)
- Platen Down** - U (Open) L (Closed)
7. Press to return to "PROGRAMMING MODE SERVICE MODE".
 8. Press again to exit.

CALIBRATION

Bi-Weekly Calibration:

Tools: Digital Pyrometer with Surface Probe

Warning: PERSONAL INJURY FROM BURNS MAY RESULT WHEN COMING IN CONTACT WITH HOT COOKING SURFACES.

NOTE: Calibration of grills is done with release material sheets installed.

NOTE: CALIBRATION REQUIREMENTS



The control software will beep to the user when it is appropriate to calibrate. The control will allow calibration provided the following conditions are met:











- Temperature is currently falling from a detected peak of 360°F or higher.
- Temperature is falling and has fallen 2°F from a detected peak that is within the 350-360°F range. (i.e. calibration would be allowed at 355°F if the achieved peak temperature was 357°F)
- Temperature is rising through the 350-360°F range as a result of a heat on pulse of less than 30 seconds.

To Calibrate:

1. The upper platens and lower grill plate should be at operating temperatures to perform this calibration procedure.

Turn on the Master Switch and press  to enter cooking mode.

2. Press  or  to select a "CLAM" operation and allow the grill to reach the set temperature and stabilize, (approximately 30 minutes).

3. Press and hold  for three, (3) seconds. "ENTER CODE" is displayed.
4. Using the Product buttons, 0-9 enter the code, (1251). "ENTER CODE **** " is displayed.
5. Press  to enter the Programming Mode. "PROGRAMMING MODE MENU ITEMS" is displayed.
6. Press  three, (3) times. "PROGRAMMING MODE SYSTEM SETUP" is displayed.
7. Press  five, (5) times. "PROBE CAL – UPPER XXXF" is displayed.
8. Place the surface probe of the digital pyrometer directly on the probe location, (see diagram on following page).
9. Allow at least 5 seconds for the pyrometer to respond and stabilize. Note the temperature on the pyrometer.
10. If the temperature on the grill control display does not match the temperature on the pyrometer, adjust the temperature on the grill control accordingly using the  and  buttons.
11. Press . "PROBE CAL – GRILL XXXF" is displayed.
12. Repeat steps 8 - 10.
13. Press  to save the changes.
14. Press  to return to "PROGRAMMING MODE SYSTEM SETUP"
15. Press  again to exit.
16. Repeat steps 1 - 15 at each control.

CALIBRATION *continued*

Probe Locations:

The grill's thermocouple probes are located on each section of the lower grill plate in the center of the cooking zone as shown in the diagram below. Each upper platen has one thermocouple probe in the center.

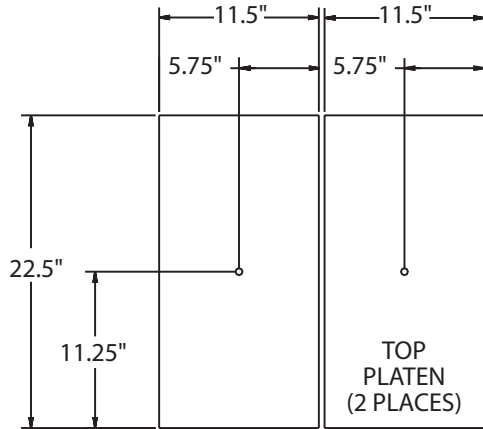

MODEL XG24-JIB

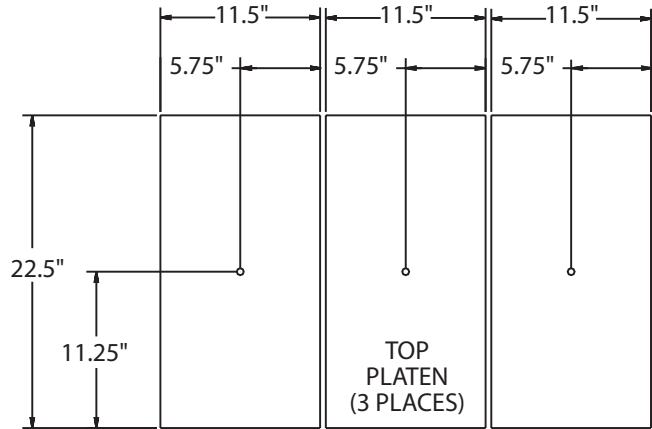

MODEL XG36-JIB

TROUBLESHOOTING

ERROR MESSAGES:

NOTE: WE STRONGLY SUGGEST THAT ANY INSTALLATION, MAINTENANCE AND REPAIRS SHOULD BE PERFORMED BY YOUR LOCAL GARLAND AUTHORIZED SERVICE AGENCY.

PROBE ERROR:

...occurs when the probe is open or not connected. The control will turn the heat off. If the fault is in the platen the grill can still be used with recipes that do not call for the platen. If the grill probe circuit is open, the grill will not operate. The corresponding tri-color LED will turn red indicating which element is in error. Programming is allowed during this time.

PLATEN DOWN ERROR:

...occurs if the platen does not reach the proper position in 40 seconds or fails to move during this time. There is an audio alarm with this message.

To cancel the message, press .

PLATEN UP ERROR:

...occurs if the platen is below the lower limit and does not move for 40 seconds.

To cancel the audio alarm press .

HEATING ERROR:

...occurs when the controller does not detect a proper temperature response over a six minute period. The corresponding tri-color LED will turn red indicates which element is in error.

COMM ERROR:

...occurs when there is no communication between the control board and the motor board.

Press  to reset the message and silence the beep.

MOTOR OVER CURRENT:

...displayed when the platen has been mechanically resisted. The platen will stop and move to the lower limit. Press the GREEN/CANCEL button to eliminate this display.

MOTOR ERROR:

...occurs when the platen is going up or down and does not get 5 encoder counts in 1 second when the platen is below the lower limit moving down or above the lower limit going up. At this message the display will flash and there will be an audio alarm. To cancel the message the power switch must be recycled.

IGNITION ERROR:

...occurs if the ignition feedback signal does not give the proper signal after four tries.

FLASHING LED(S):

...occurs after a failure for the ignition module to ignite the gas. The grill LED will flash while the control tries again. If successful the LED will continue to flash until set temperature is reached and then turn to a solid green.

TECHNICAL TROUBLESHOOTING

Master Power (ON / OFF) Switch turned ON - Power light or indicator is not lit

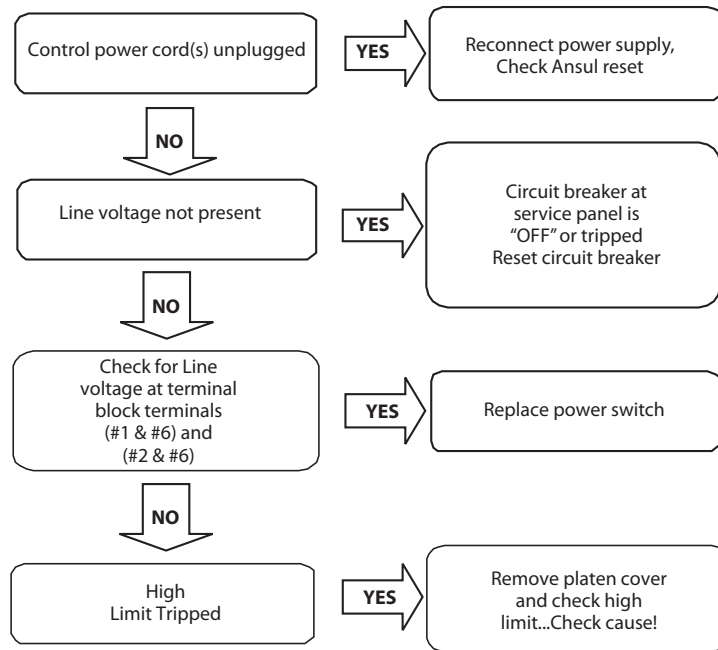

Low Internal Product Temperatures

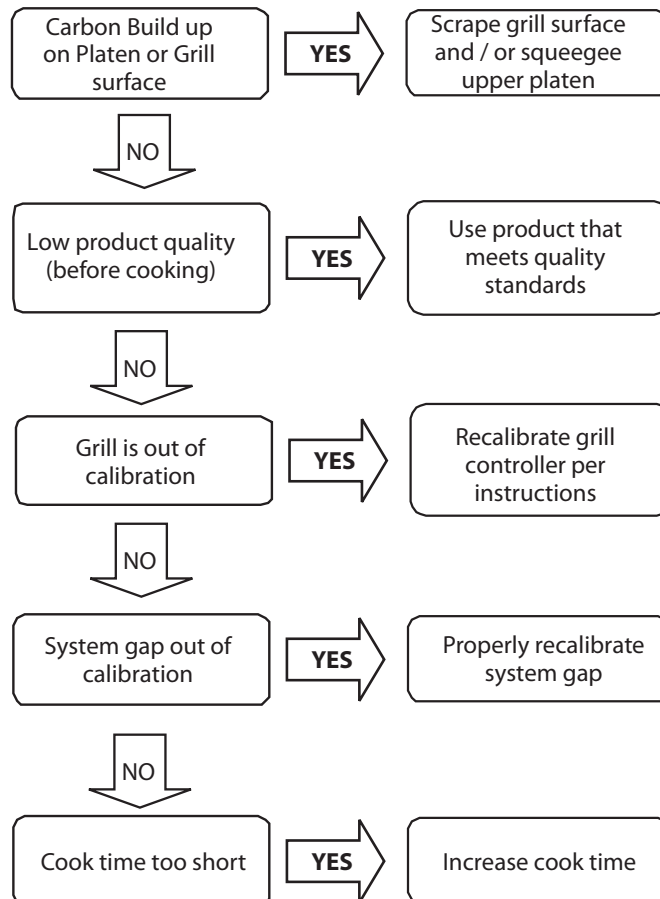

Controller Displays "Too Hot"

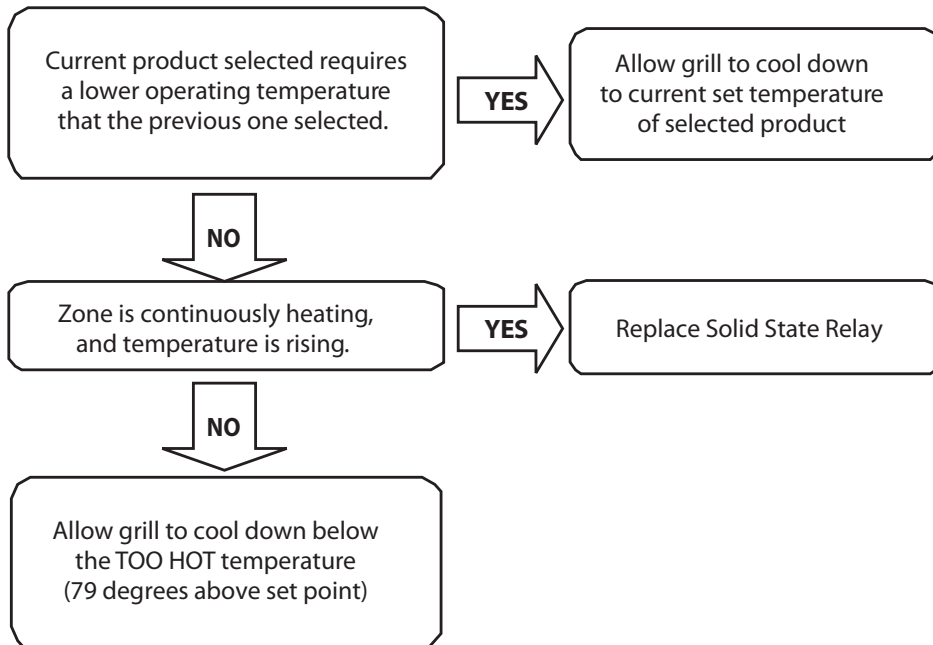

TECHNICAL TROUBLESHOOTING *continued*

Controller Displays "FAULTY ELEMENT OR SHORTED PROBE" - Only 1 or 2 zones LED lights are RED

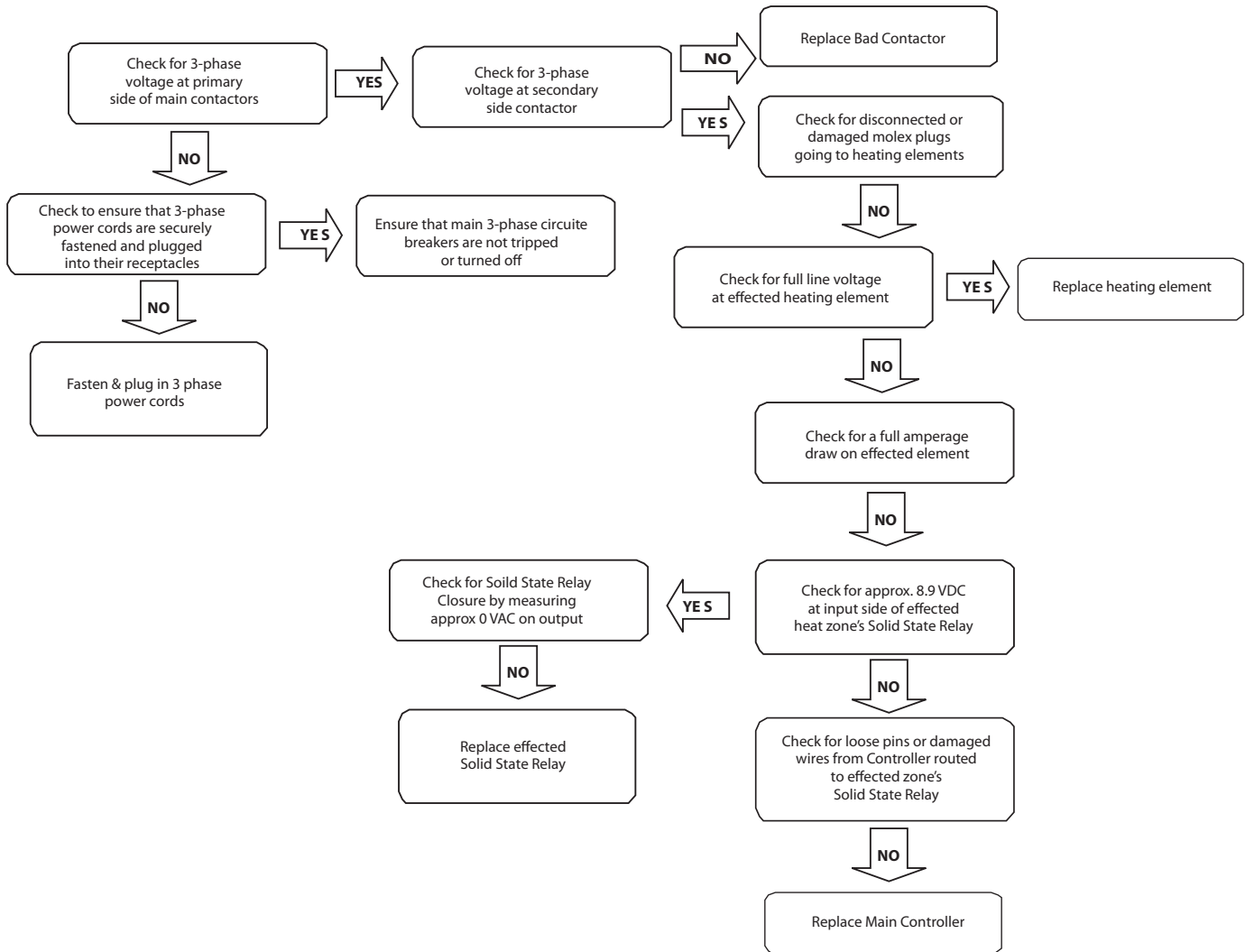

Controller displays "PROBE ERROR"

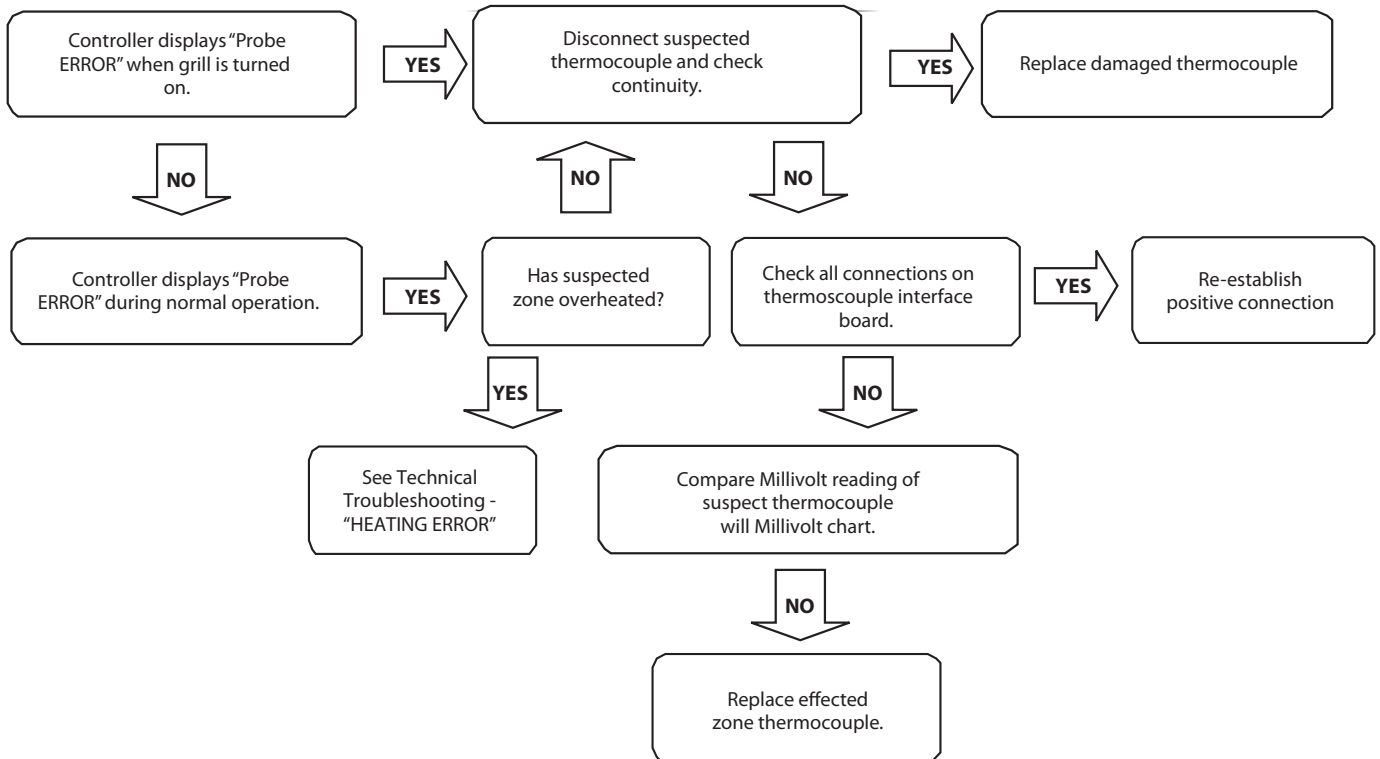

TECHNICAL TROUBLESHOOTING *continued*

Controller Displays "HEATING ERROR or PROBE ERROR PLATEN and GRILL LED's are RED (Both Sides)

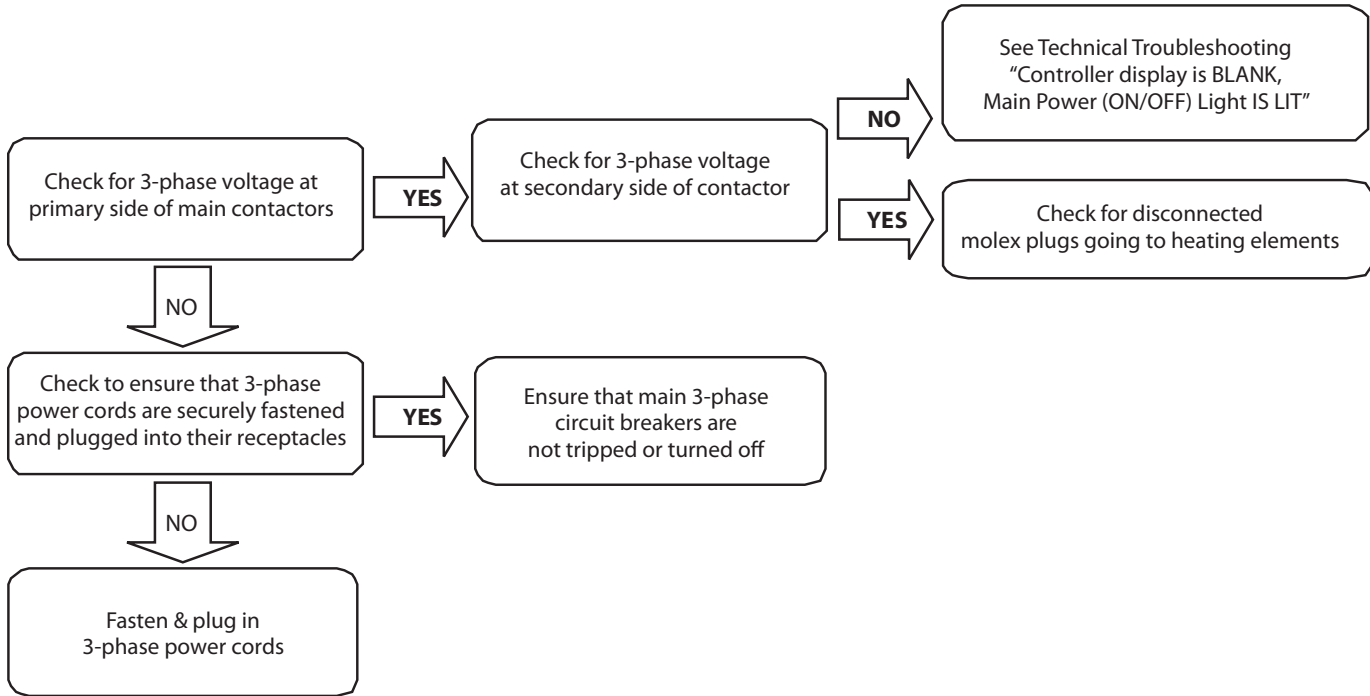

Inconsistent Or Erratic Internal Product Temperature

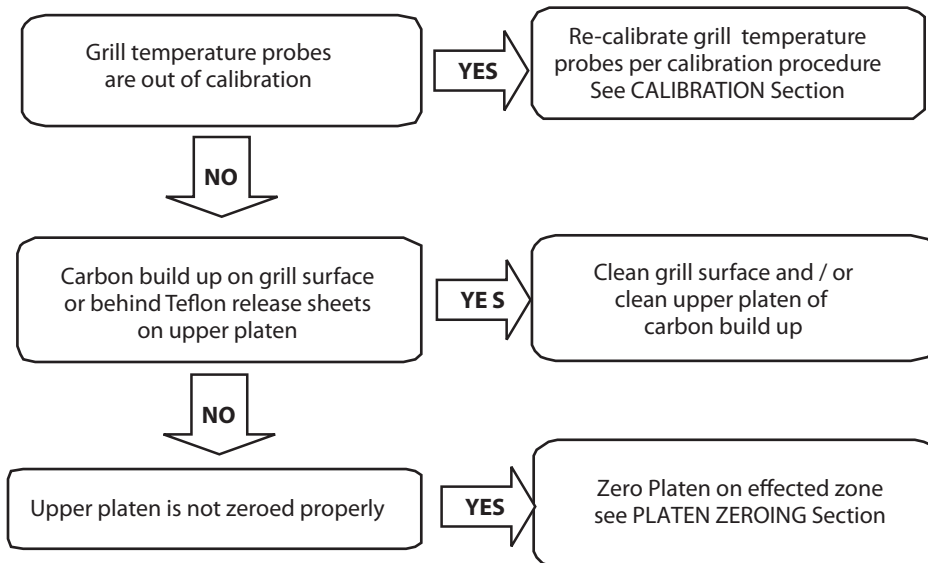

Controller Display is BLANK, Main Power (ON / OFF) light or indicator is LIT

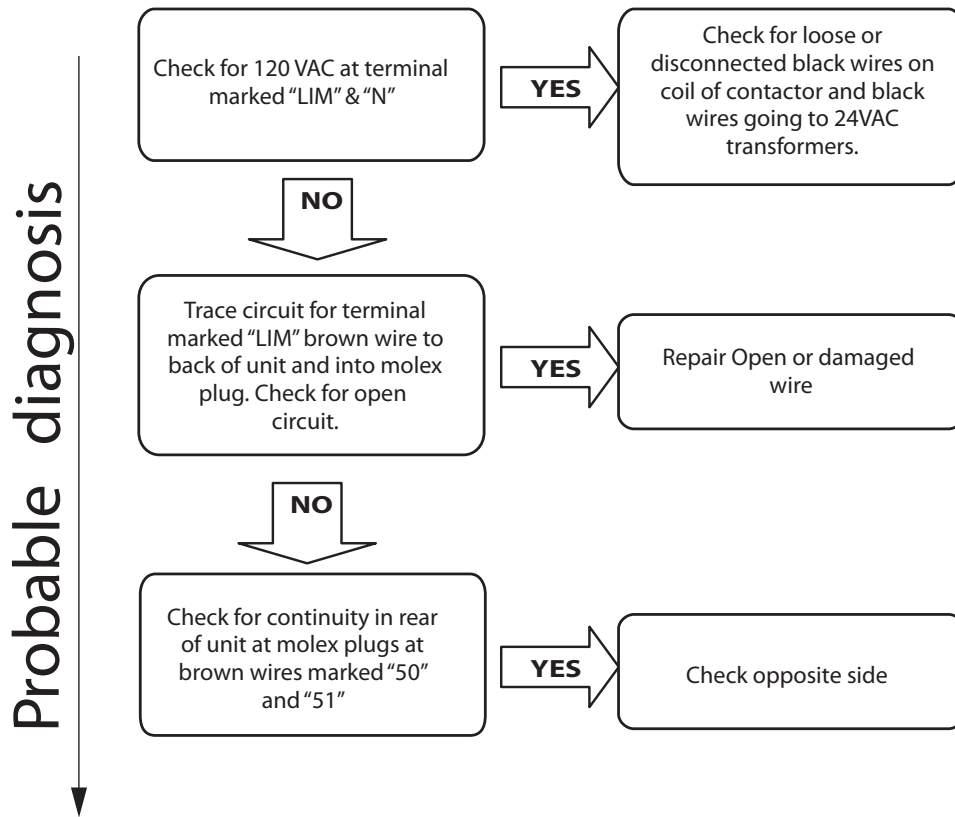

TECHNICAL TROUBLESHOOTING *continued*

Master Power (ON / OFF) Switch turned ON - Power Light in On - Grill is not heating

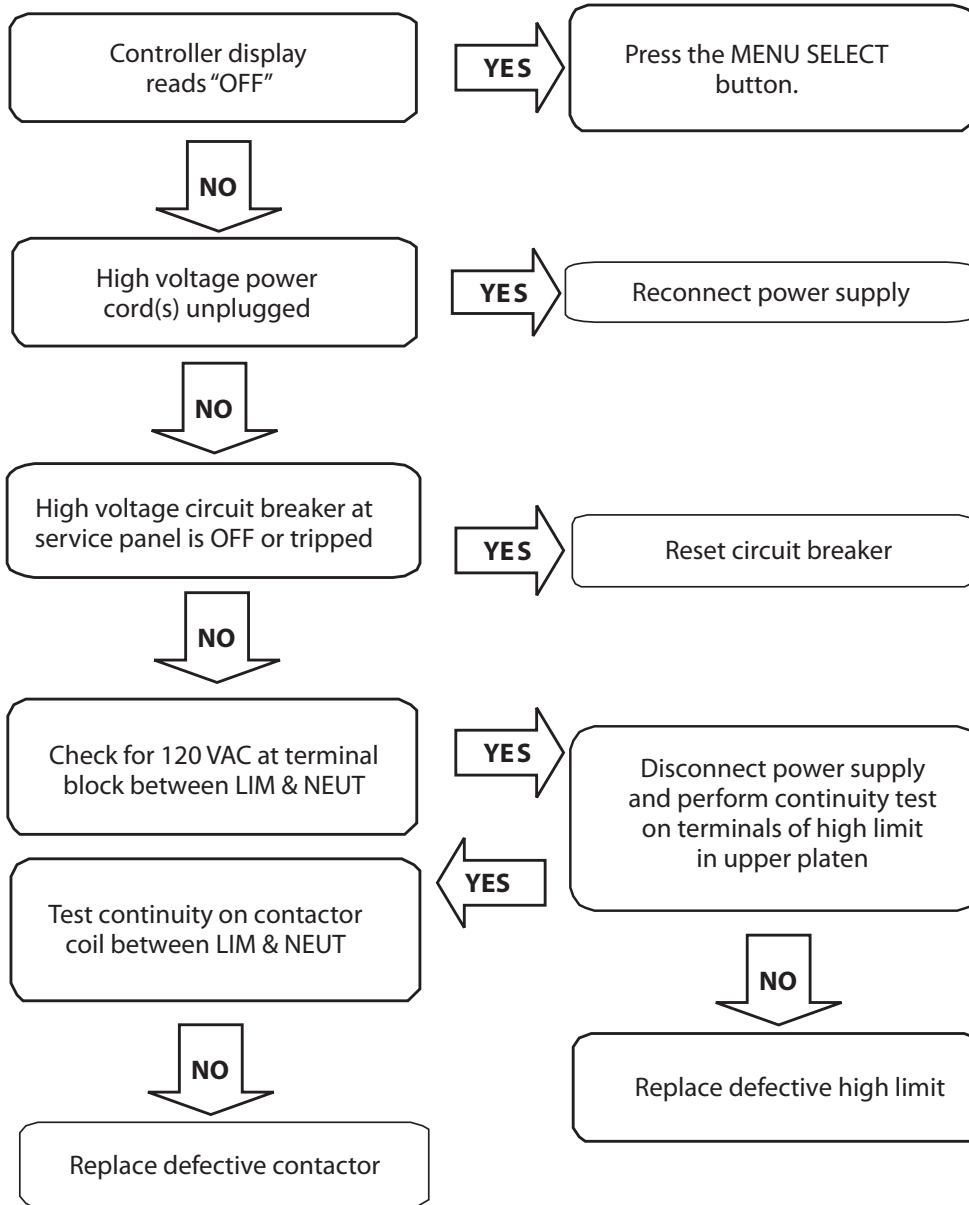

TECHNICAL TROUBLESHOOTING *continued*

Controller Displays "MOTOR OVER CURRENT" - Platen does not move at all

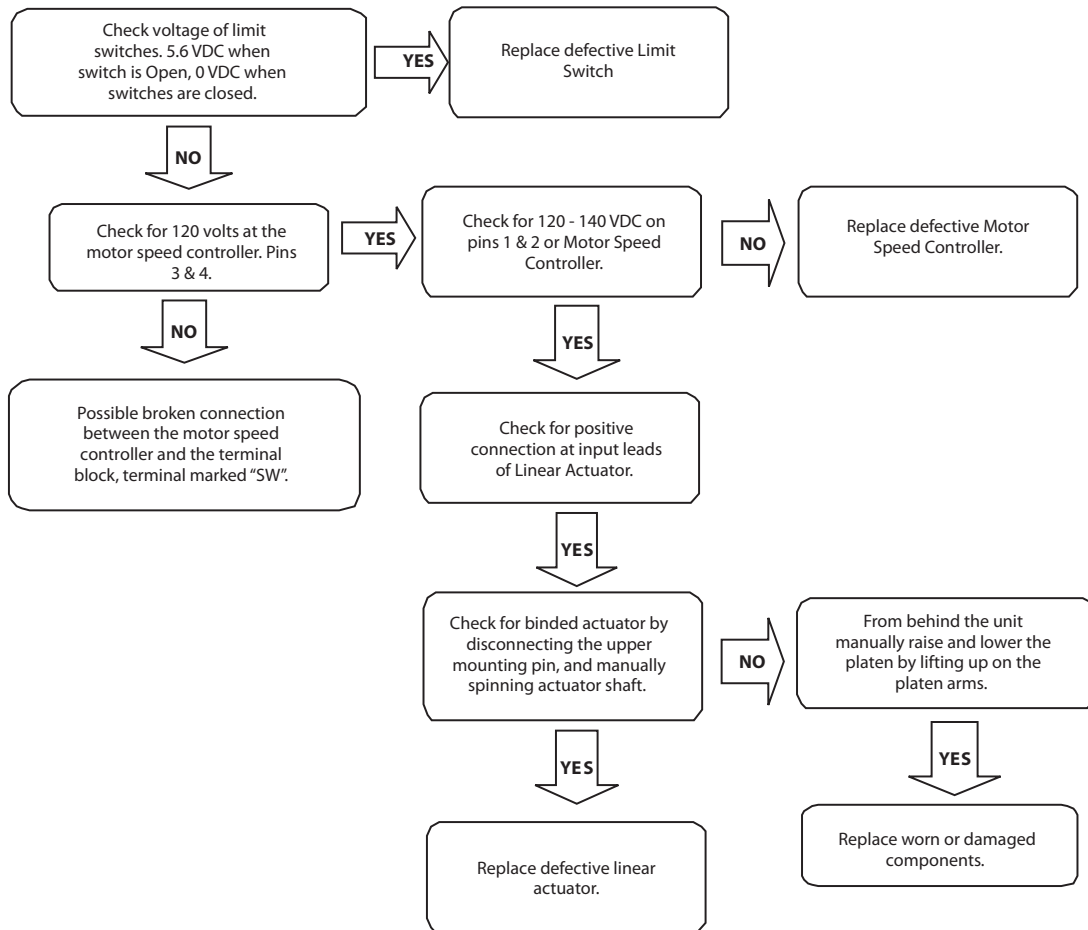

Controller Displays "MOTOR OVER CURRENT" - Platen stops and moves to lower limit

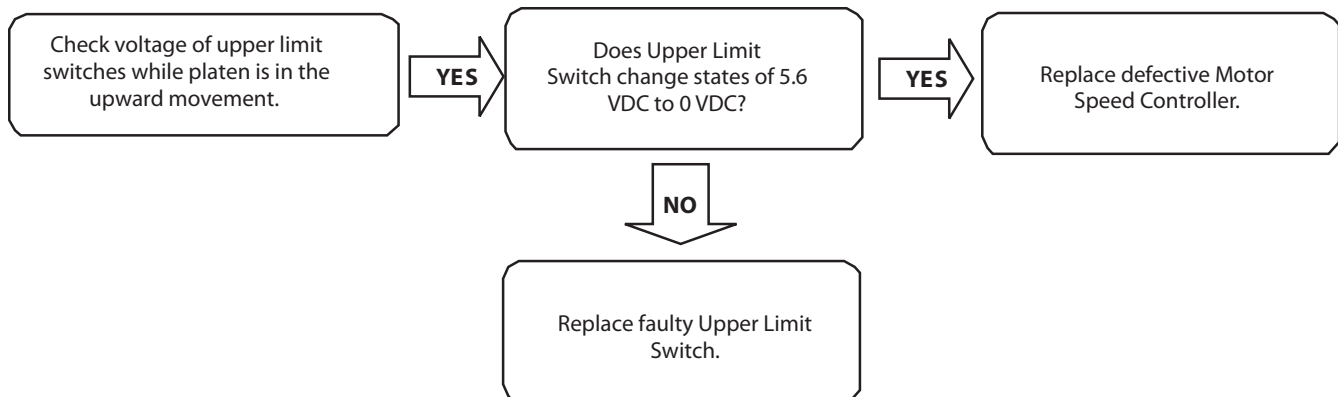

TECHNICAL TROUBLESHOOTING *continued*

Controller Displays "IGNITION FAILURE" - No flame at all

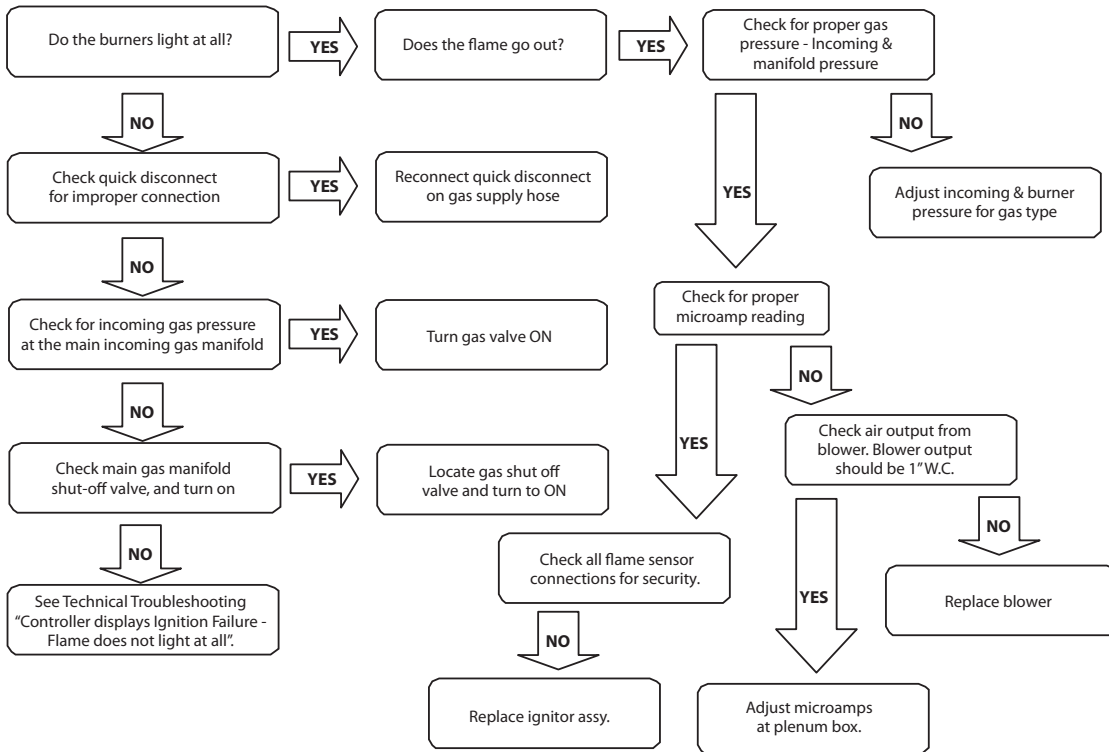

Controller Displays "IGNITION FAILURE" - Flame does not light at all

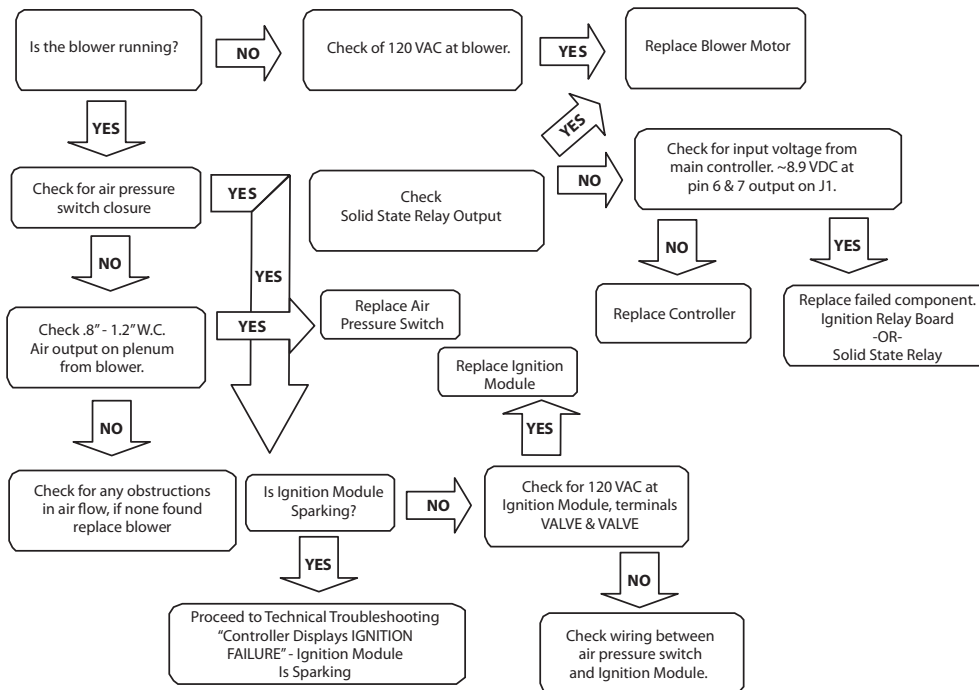

TECHNICAL TROUBLESHOOTING *continued*

Controller Displays "IGNITION FAILURE" - Module is sparking, flame comes on and goes out

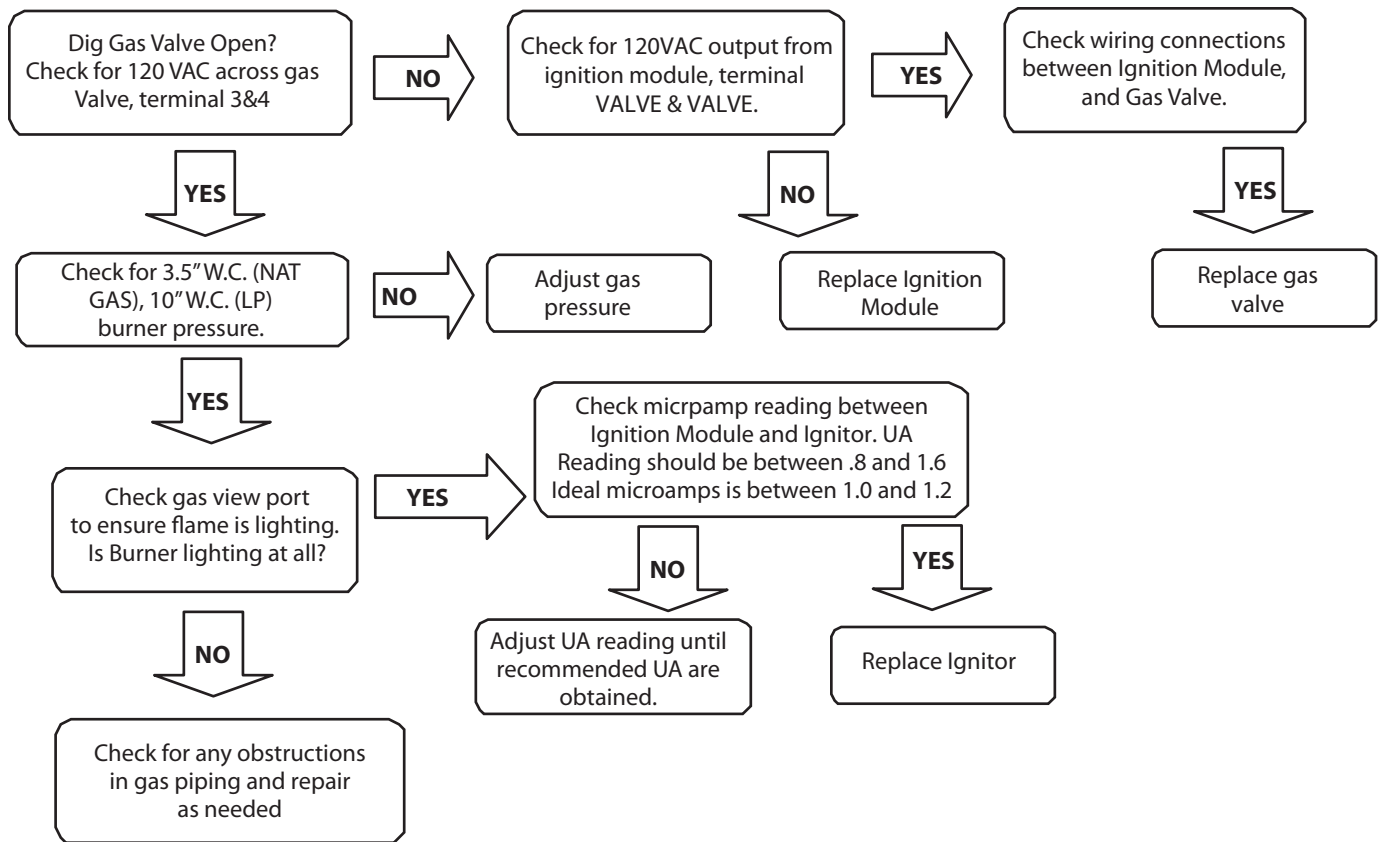

LINEAR ACTUATOR REPLACEMENT

1. Disconnect the cable from the Motor Speed Control.

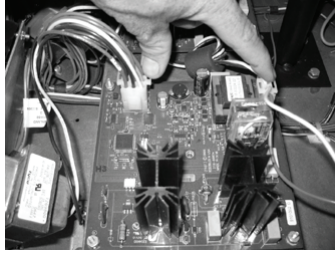

2. Disconnect the motor leads from the wire harness.

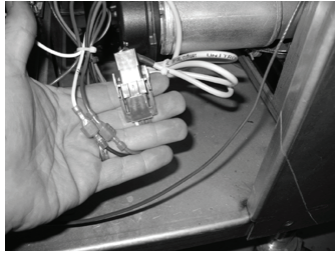

3. With the platen in the UP position, support it with a pry bar, 2x4, etc., from behind the platen arm assembly. Pull the platen arm toward the rear of the grill to insert.

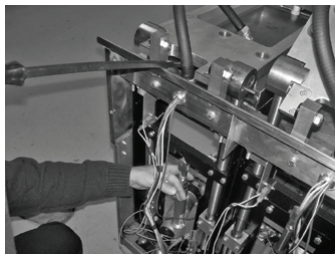

4. With the weight of the platen supported by the object inserted in step 3, use pliers to work the clevis pin retaining clip outward, making sure to grip it as close to the pin as possible to prevent deforming it.

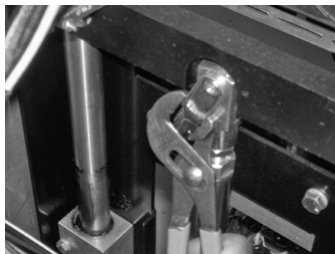

5. Use the pliers to remove the spring clip from the pin at the base of the Linear Actuator.

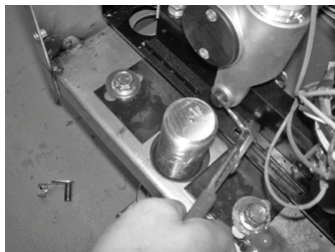

6. Push the pin through the actuator base toward the inside of the grill. Reach around to the inside and remove.

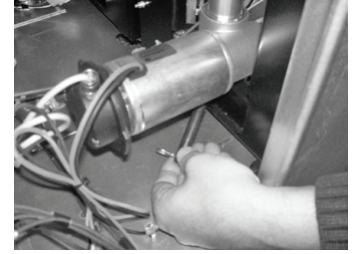

7. Remove the Linear Actuator from the grill, carefully pulling it out the rear.



8. Support the weight of the platen while removing the pry bar. Then, carefully lower platen to the down position, resting it on the grill plate.

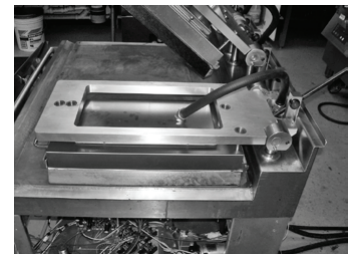

9. Screw NEW linear actuator shaft down approximately 2 turns from bottoming out. DO NOT completely bottom out shaft as it may not be long enough to reconnect the upper clevis clip.



10. Re-install linear actuator into rack assembly. If motor does not clear the cross member, use pry bar to gently lift and fit as previously done in step 3. Reinstall actuator base pin from inside and remount its spring clip.



LINEAR ACTUATOR REPLACEMENT *continued*

11. Gently fit clevis clip through top of actuator shaft and cross member bar. Use pry bar to align holes.

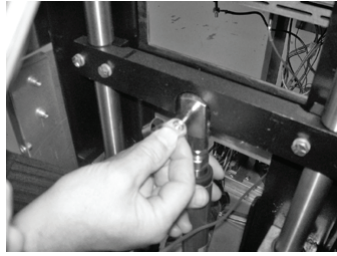

12. Reconnect wires as shown in the photos to the right.

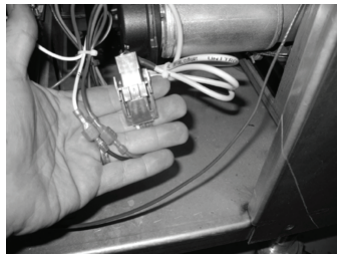
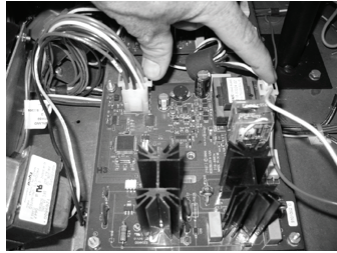

***PARTS LIST
MASTER SERIES
XG24-JIB XPRESS GRILL GAS***

Contents

XPRESS - GRILL COMPLETE VIEW..... 50
XPRESS GRILL ACTUATOR 52
XPRESS GRILL PLATEN 54
XPRESS GRILL BURNER..... 56
XPRESS GRILL COMPONENT BRACKET 58
XPRESS GRILL HEAT SINK..... 60
REVISION HISTORY..... 62

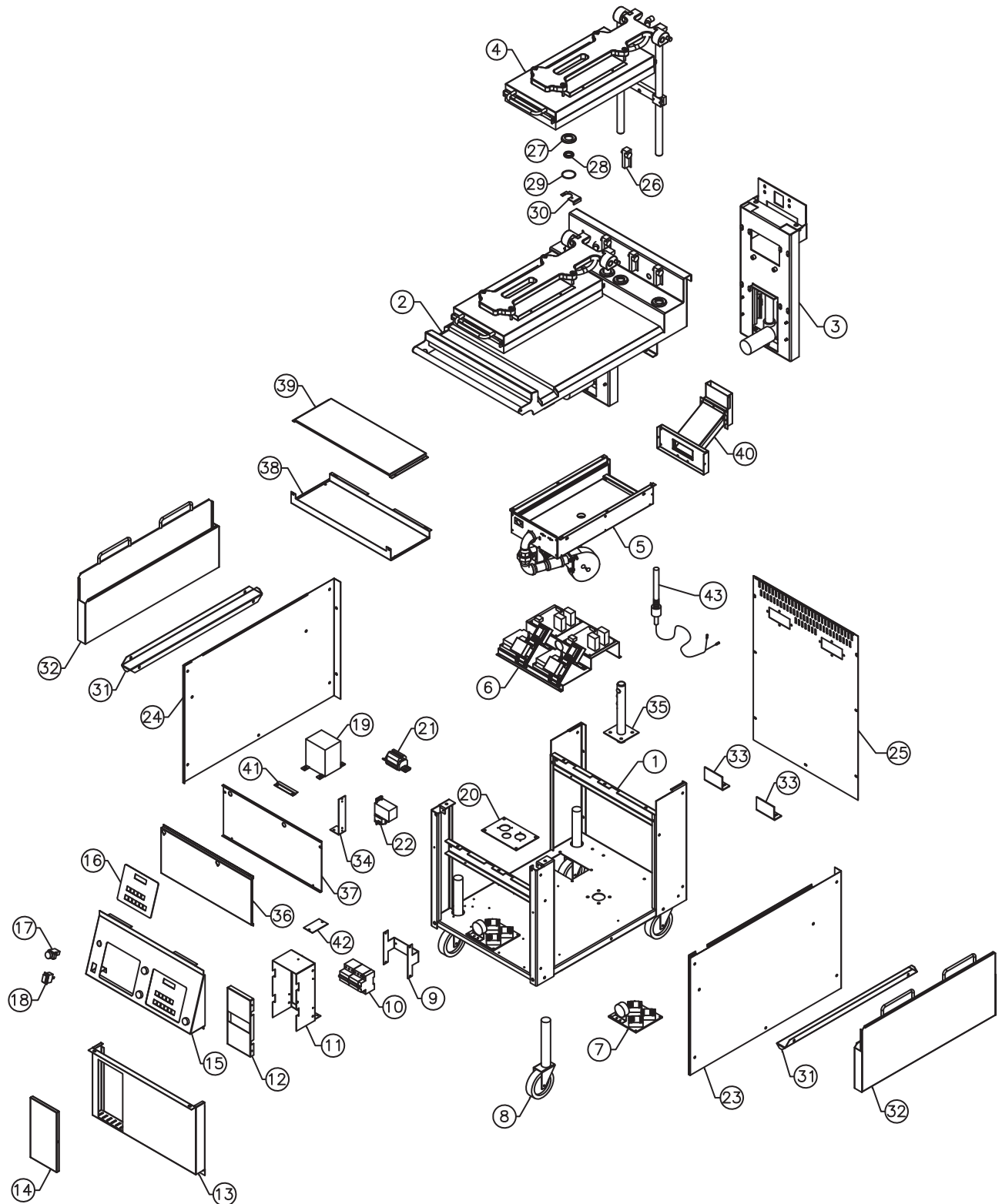

XG24-JIB#1

GARLAND PARTS IDENTIFICATION

Gas - Xpress Grill Complete Exploded View - Model: XG24-JIB

ITEM	PART #	DESCRIPTION	QUANTITY
1	4516708	Body Base Wa	1
2	4516718	Plate Wa	1
3	Page 52	Actuator Assembly	2
4	Page 54	Platen Assembly	2
5	Page 56	Burner Assembly	2
6	Page 58	Component Bracket Assembly	1
7	Page 60	Heat Sink Assembly	2
8a	4516978	Caster, Nonlocking	2
8b	4517563	Caster, Locking	2
9	4516689	Circuit Support	1
10a	4516980	Circuit Brkr, 1 Pole	1
10b	4517425	Circuit Brkr, 3 Pole	2
11	4516687	Circuit Box	1
12	4516688	Circuit Cover	1
13	4516685	Front Panel Lower	1
14	4516686	Circuit Door	1
15	4516684	Front Panel Upper	1
16	4516983	Control	2
17a	1859601	Push Button	4
17b	1859603	Contact Block	4
18	1872400	Power Switch	1
19	4517132	Transformer	1
20	1868901	Power Cord Plate	1
21	4516982	Terminal Block, 10Mm	1
22	4516981	Terminal Block, 120V	1
23	4516105	Body Side, Right	1
24	4516106	Body Side, Left	1
25	4517393	Back	1
26a	1856801	Arm Pivot Block	4
26b	1854901	Cam Follower	4
27	4516098	Seal Cap	4
28	4517006	Wiper Seal	4
29	1874201	O-Ring	4
30a	4517013	Seal Cap Bracket Lt	2
30b*	4517014	Seal Cap Bracket Rt	2
31	4516976	Grease Bucket Support	2
32	4516308	Grease Bucket Wa	2
33	4516977	Actuator Base Brace	2
34	4517025	Terminal Bracket	1
35	4517394	Gas Inlet	1
36	4517388	Front Heat Shield, Outer	1
37	4517389	Front Heat Shield, Inner	1
38	4517390	Burner Heat Shield, Lower	1
39	4517391	Burner Heat Shield, Upper	1
40	Page 54	Flue Assembly	
41	1869301	Transformer Bracket	1
42	4516114	Circuit Brace	1
43	4520578	Grill Thermocouple	1

* NOT ILLUSTRATED

RECOMMENDED STOCK PARTS

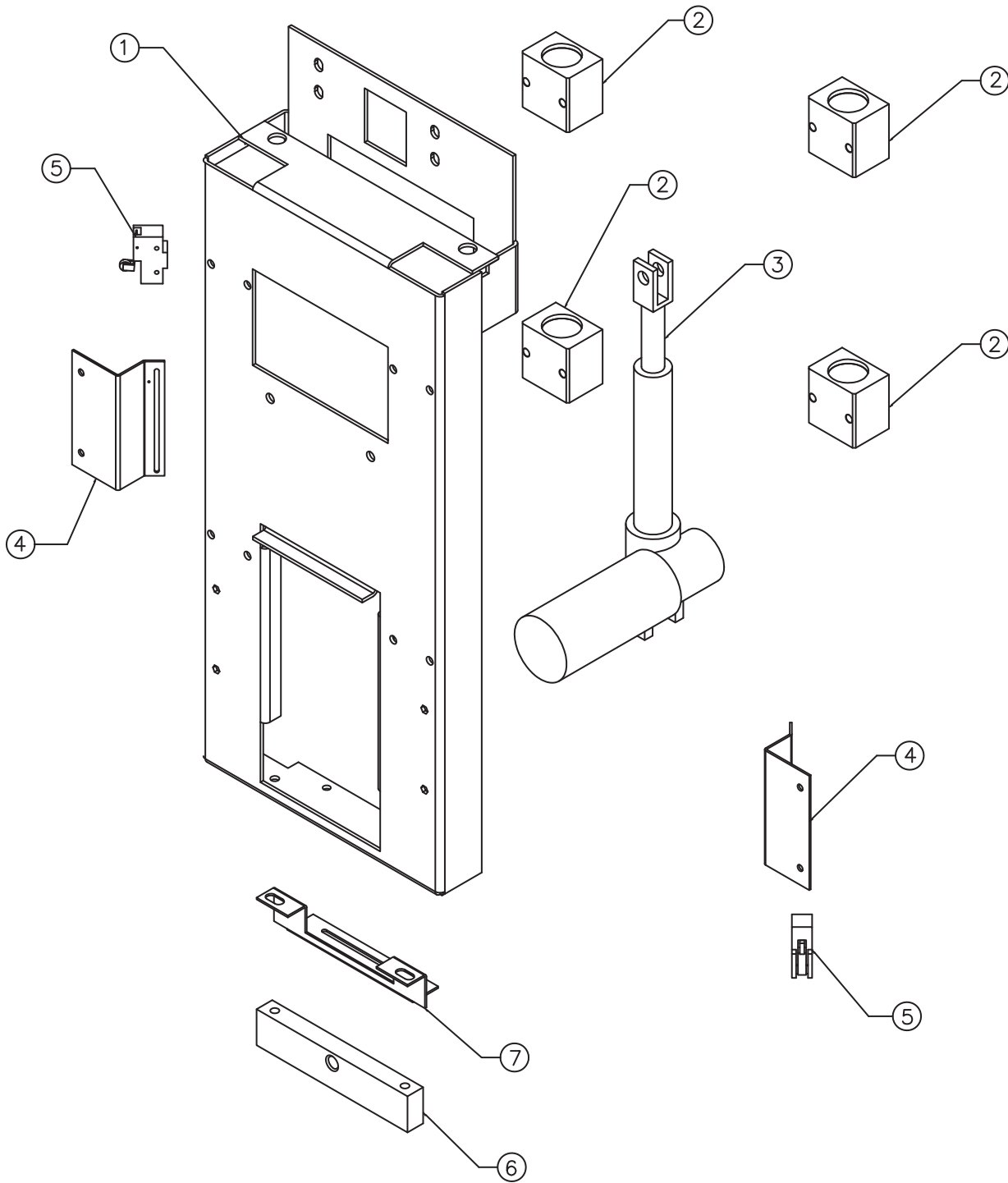

XG24-JIB#2

GARLAND PARTS IDENTIFICATION

Gas - Xpress Grill Actuator Assembly View - Model: XG24-JIB

ITEM	PART #	DESCRIPTION	QUANTITY
1	4516080	Actuator Frame Wa	1
2	4516096	Pillow Block	4
3	1812401	Actuator	1
4	1857601	Switch Bracket	2
5	1855601	Upper/Lower Platen Limit Switch	2
6	1858001	Actuator Mount Block	1
7	4516097	Actuator Base Bracket	1

* NOT ILLUSTRATED

RECOMMENDED STOCK PARTS

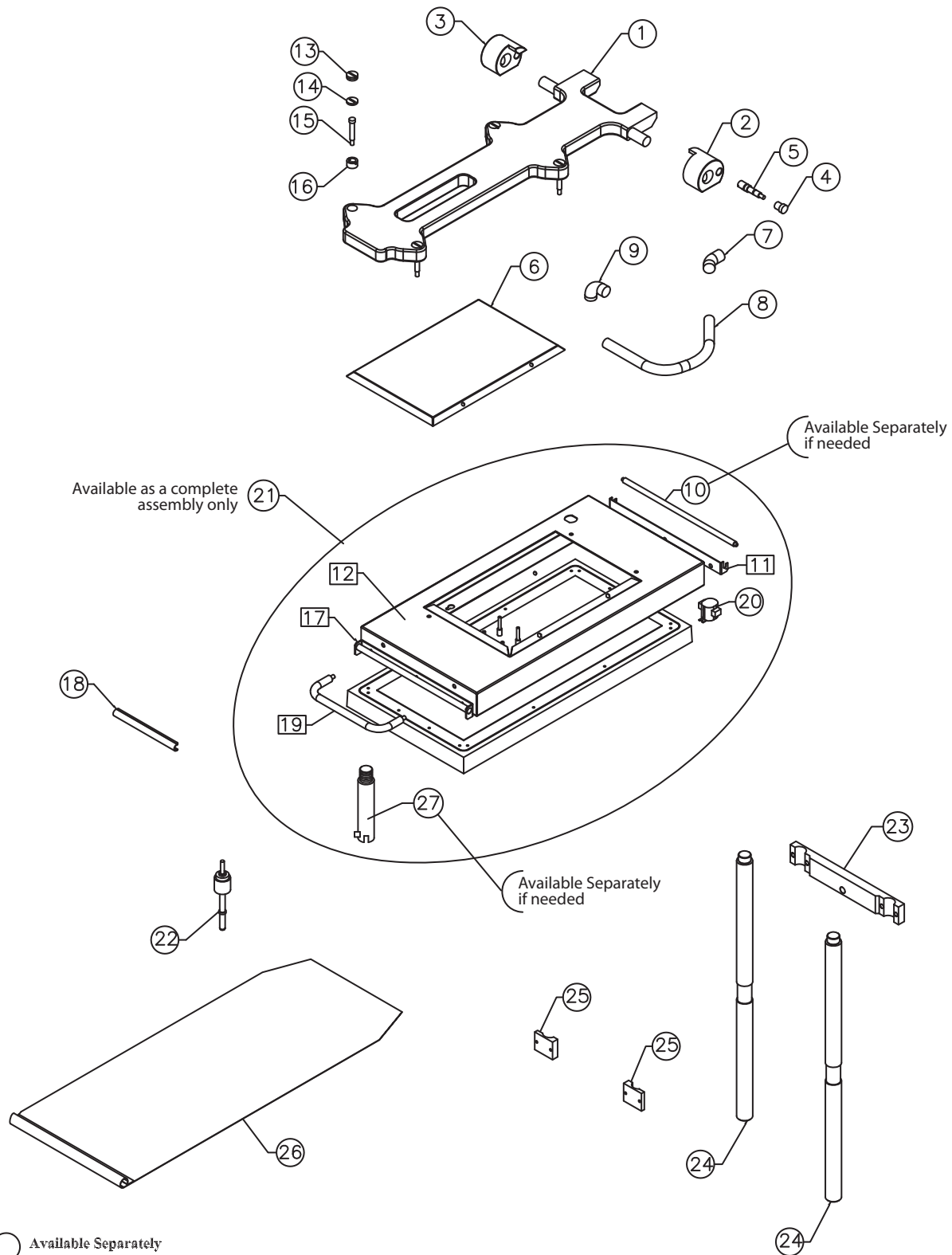

- Available Separately
- Not Available Separately

XG24-JIB#3

GARLAND PARTS IDENTIFICATION

Gas - Xpress Grill Platen Assembly View - Model: XG24-JIB

ITEM	PART #	DESCRIPTION	QUANTITY
1	4516085	Platen Arm	1
2	4516087	Carriage Block, Rt	1
3	4516088	Carriage Block, Lt	1
4	1858501	Pivot Stop Knob	1
5	1858502	Pivot Stop Pin	1
6	4516092	Platen Lid	1
7	4517021	3/8 Connector, 45 Deg	1
8	4517022	Platen Conduit	1
9	4517020	3/8 Connector, 90 Deg	1
10	4517008	Teflon Bar, Rear	1
11	4516094	Teflon Holder, Rear (Not Available Separately)	1
12	4516091	Platen Cowl (Not Available Separately)	1
13	1859102	Platen Adjuster Cap	4
14	1859103	Platen Lock Nut	4
15	8005401	Shoulder Bolt	4
16	1859101	Platen Adjuster Nut	4
17	4516093	Teflon Holder, Front (Not Available Separately)	1
18	1851301	Teflon Clip	1
19	1859501	Upper Platen Handle (Not Available Separately)	1
20	1781301	Hi Limit - Auto Reset	1
21	4519752	Platen Assembly Complete 208V	1
	4519753	Platen Assembly Complete 220V	1
	4519755	Platen Assembly Complete 240V	1
22	1859401	Platen Thermocouple	1
23	4516089	Cross Member	1
24	4516084	Actuator Shaft	2
25	4516090	Cross Member Bracket	2
26	1799303	Teflon Sheet	1
27	1859402	Grill Plate/Platen Bayonet Adapter	1

* NOT ILLUSTRATED

RECOMMENDED STOCK PARTS

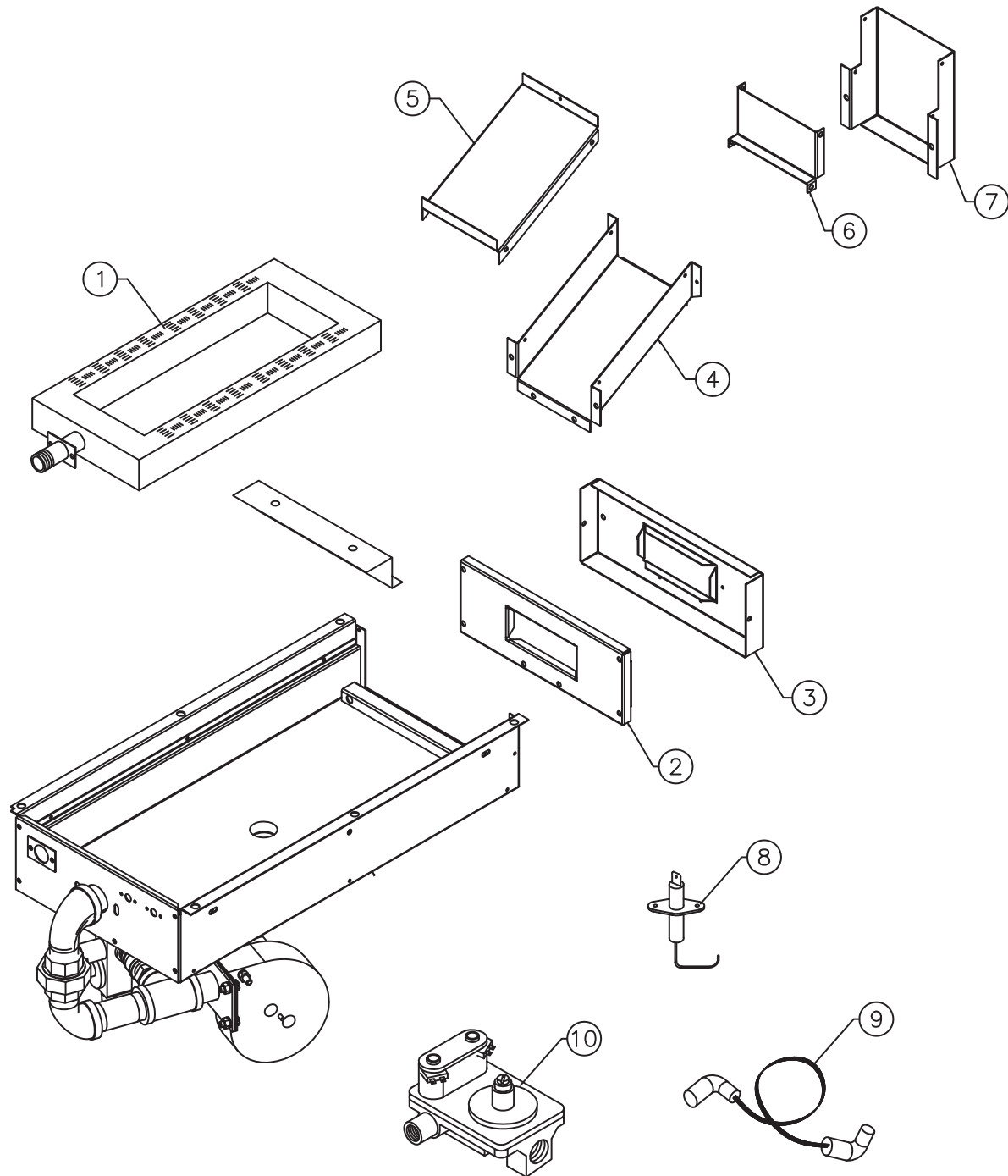

XG24-JIB#4

GARLAND PARTS IDENTIFICATION

Gas - Xpress Grill Burner Assembly View - Model: XG24-JIB

ITEM	PART #	DESCRIPTION	QUANTITY
1	4517403	Burner Assembly, Lp	1
	4517462	Burner Assembly, Nat	1
2	4517396	Flue Box, Inner	1
3	4517397	Flue Box, Outer	1
4	4517398	Flue Bottom	1
5	4517399	Flue Top	1
6	4517401	Flue Riser, Inner	1
7	4517400	Flue Riser, Outer	1
8	4524066	Igniter	1
9	4517967	Ignition Cable	1
10	1864701	Gas Valve - Nat	1

* NOT ILLUSTRATED

RECOMMENDED STOCK PARTS

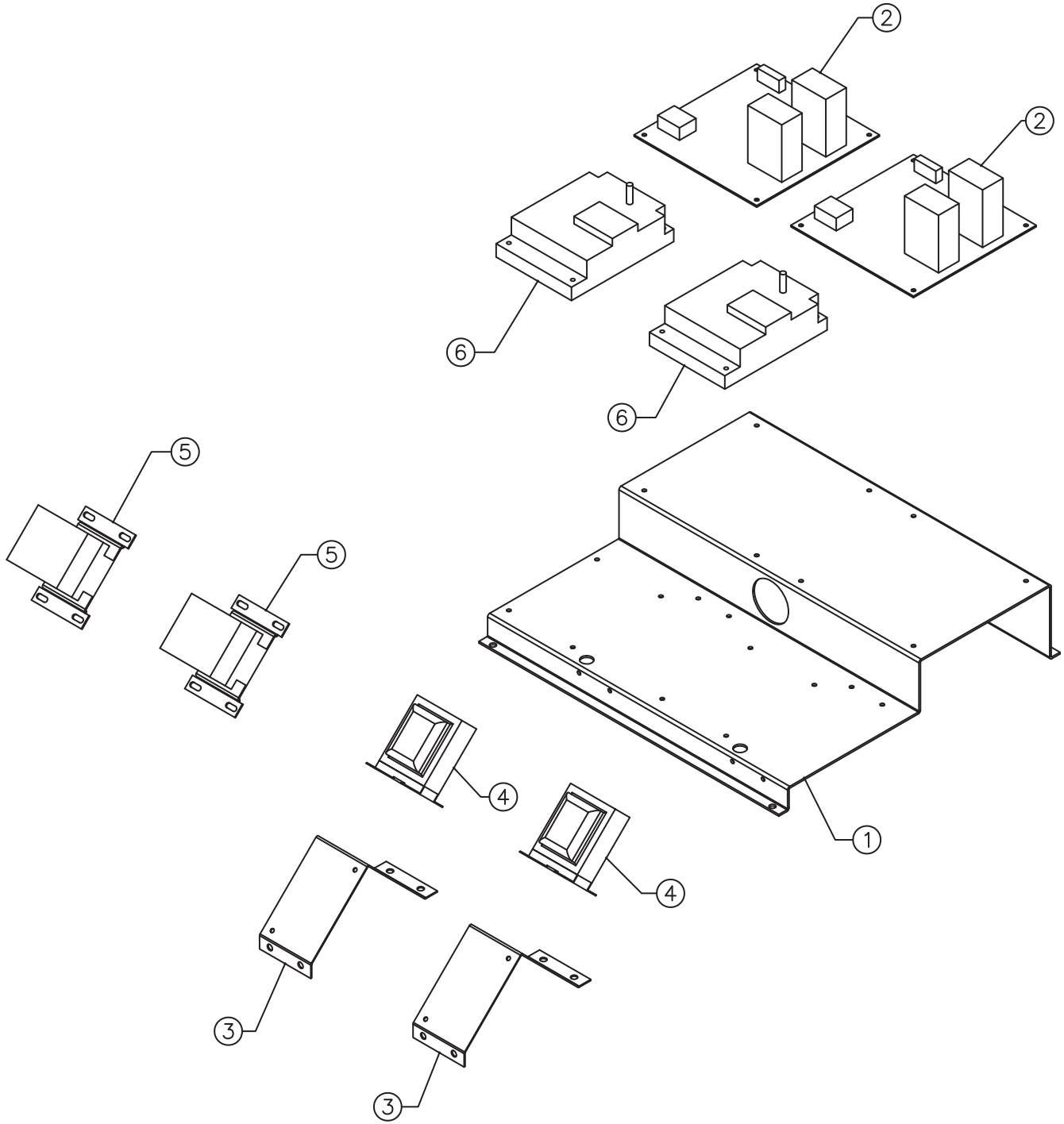

XG24-JIB#5

GARLAND PARTS IDENTIFICATION

Gas - Xpress Grill Component Bracket Assembly View - Model: XG24-JIB

ITEM	PART #	DESCRIPTION	QUANTITY
1	4516682	Component Bracket	1
2	4516989	Motor Speed Control	2
3	4516079	Contactora Bracket	2
4	1269800	24 Volt Transformer	2
5	1637001	Contactora	2
6	1864901	Ignition Module	2

* NOT ILLUSTRATED

RECOMMENDED STOCK PARTS

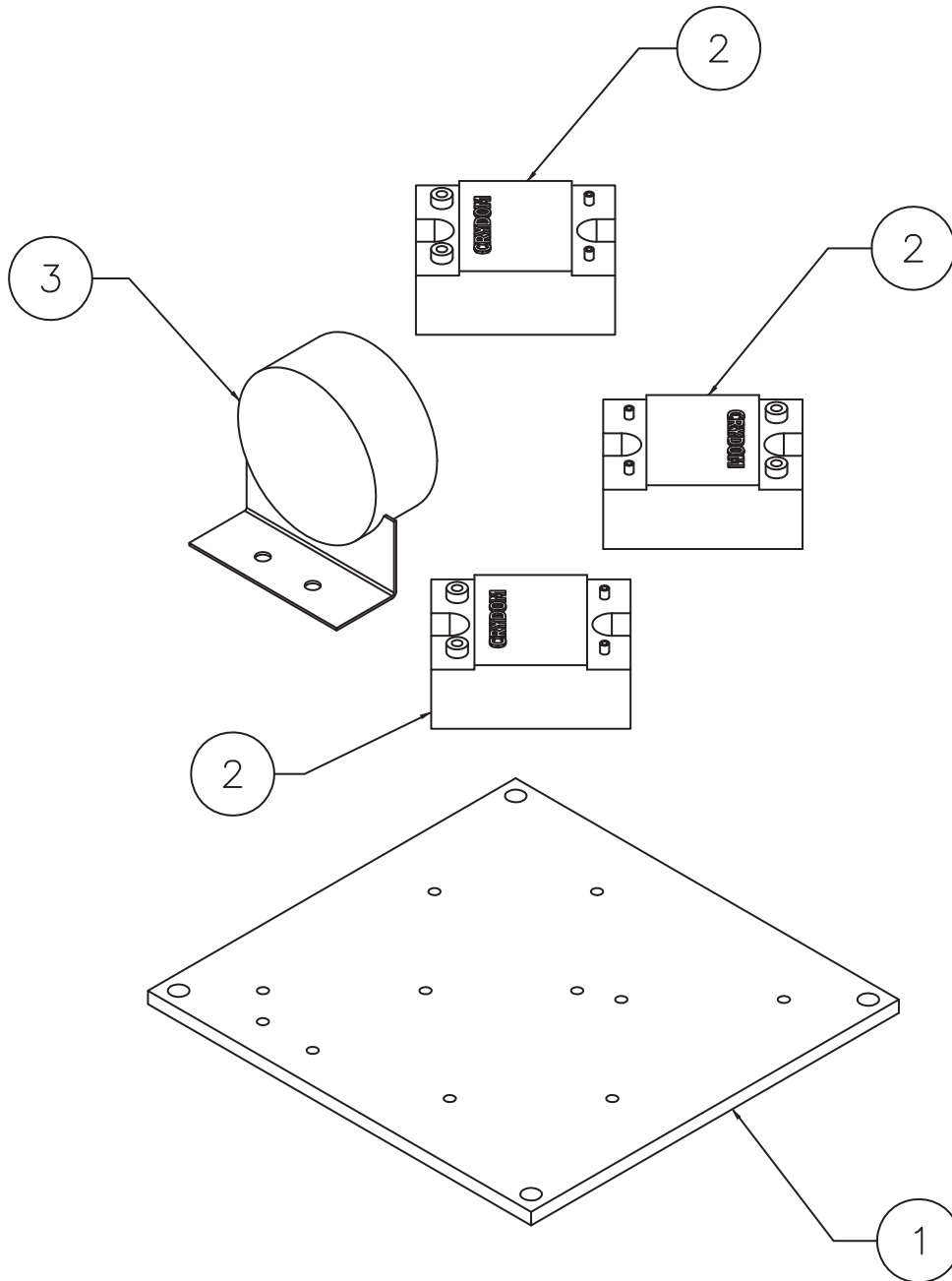

GARLAND PARTS IDENTIFICATION

Gas - Xpress Grill Heat Sink Assembly View - Model: XG24-JIB

ITEM	PART #	DESCRIPTION	QUANTITY
1	4516116	Heat Sink	1
2	4516988	Relay	4
3	4517392	Pressure Switch	1

* NOT ILLUSTRATED

RECOMMENDED STOCK PARTS

REVISION HISTORY

GARLAND PARTS IDENTIFICATION

Revision History

REV. #	PAGE #	ITEM #	NOTE	DATE
			Part List Book Released	Jul 16/08

PARTS LIST MASTER SERIES XG36-JIB XPRESS GRILL GAS

Contents

GRILL COMPLETE ASSEMBLY	64
ACTUATOR ASSEMBLY	68
PLATEN ASSEMBLY.....	70
XPRESS GRILL BURNER	72
XPRESS GRILL BRACKET	74
XPRESS GRILL HEAT SINK.....	76
WIRING HARNESS AND DESCRIPTION WHERE USED.....	78
ACCESSORIES AND TOOLS.....	79
GAS TUBING,	80
REVISION HISTORY.....	81

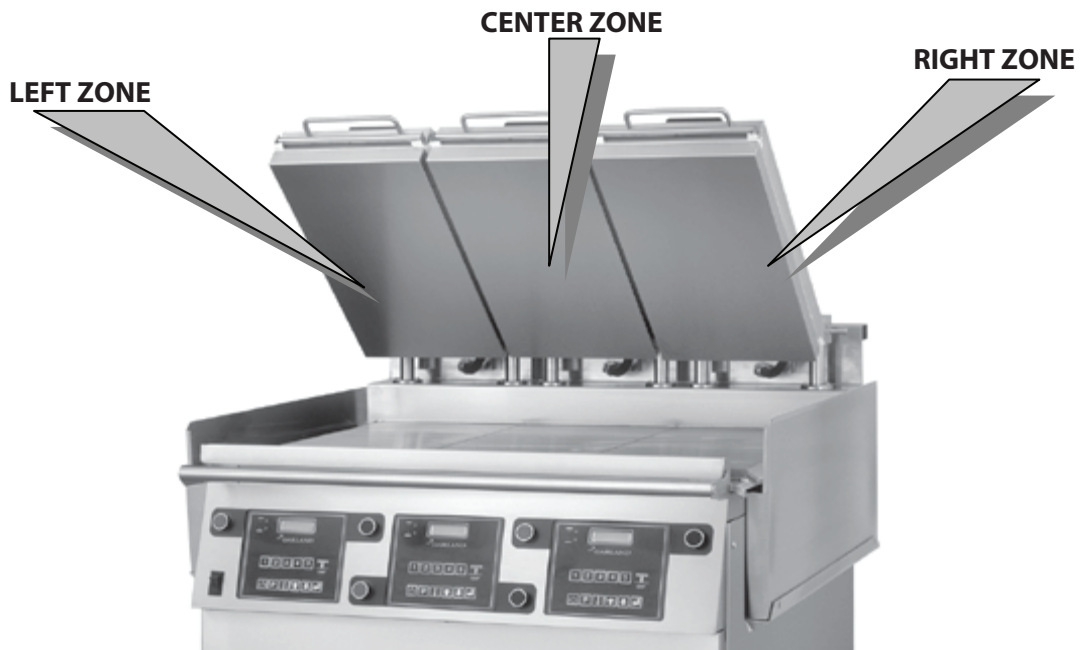

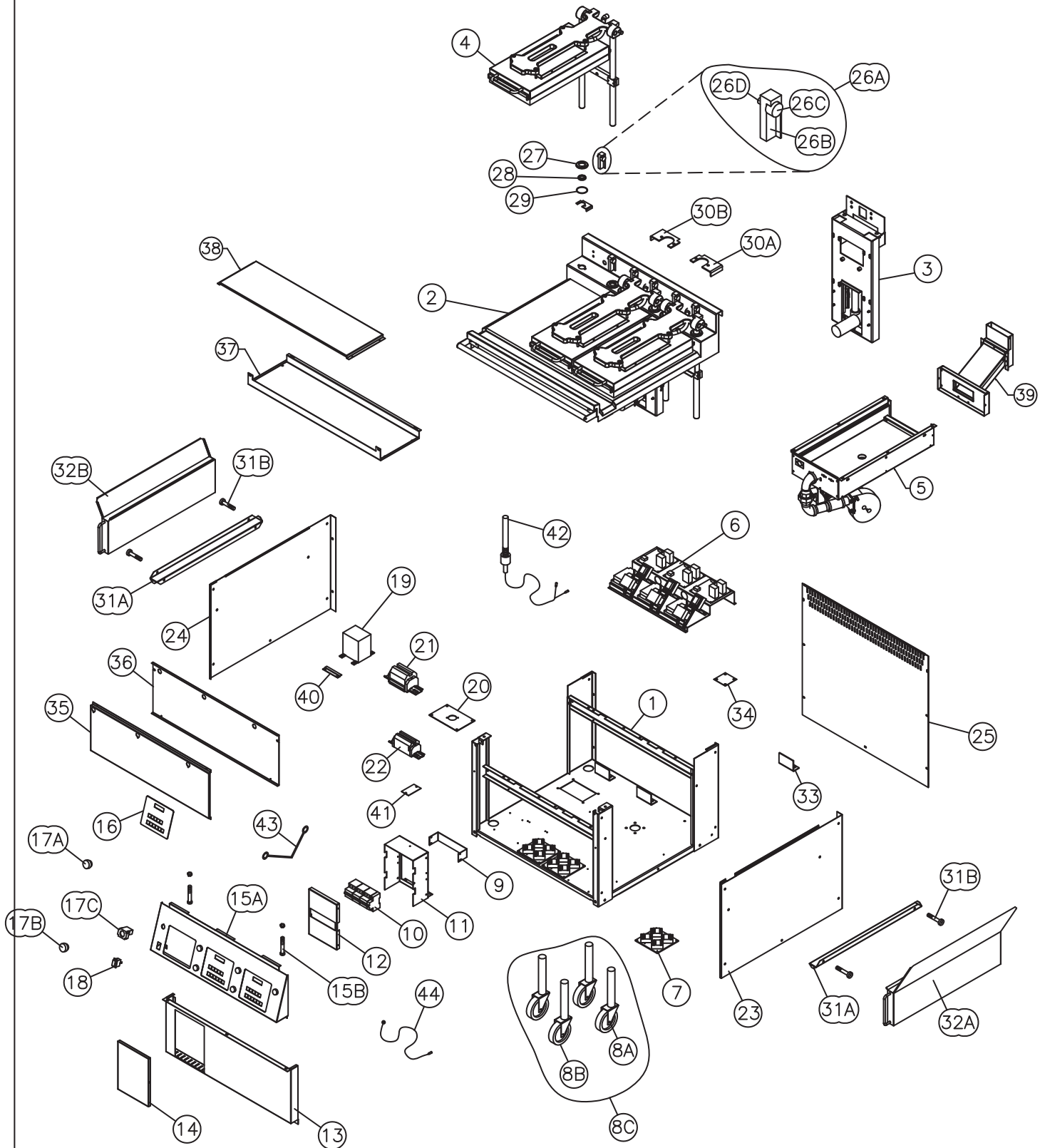

XG36 - JIB#1

GARLAND PARTS IDENTIFICATION

Gas - Xpress Grill Complete Exploded View - Model: XG36-JIB

ITEM	PART #	DESCRIPTION	QUANTITY	CRITICAL
1	4516058	Body Base Weld Assembly	1	
2	4517657	Plate Weld Assembly	1	
3	Page 68	Actuator Assembly	2	
4	Page 70	Platen Assembly	2	
5	Page 72	Burner Assembly	1 per zone	
6	Page 74	Component Bracket Assembly	1 per zone	
7	Page 76	Heat Sink Assembly	1 per zone	
8A	4516978	Caster, Nonlocking	2	
8B	4517563	Caster, Locking	2	
8C	4520678	Caster Kit - Locking & Nonlocking	1	
9	4516113	Circuit Support	1	
10	4517814	Circuit Brkr, 3 Pole	1	C
11	4516111	Circuit Box	1	
12	4516112	Circuit Cover	1	
13	4516109	Front Panel Lower	1	
14	4516110	Access Door	1	
15A	4516108	Front Panel Upper	1	
15B	8003219	MSCR-PH-PHIL 8-32 X ½ STL ZP	4	
	8001203	Nut - Hex - STL 8-32	4	
	8000202	LKWSH R - SPL-STL 8X1 9/64X3/64	4	
16	4524590	Control	1 per zone	C
17A	1859604	Push Button (Black)	1 per zone	
17B	1859605	Push Button (Green)	1 per zone	
17C	1859606	Contact Block	2 per zone	C
18	1872404	Power Switch	1	C
19	1864001	Main Transformer	1	C
20	1868904	Power Cord Plate (JIB)	1	
21	4525397	Terminal Block, 10Mm	1	C
22	4516981	Terminal Block, 120V	1	C
23	4516105	Body Side, Right	1	
24	4516106	Body Side, Left	1	
25	4517658	Back	1	
26A	4520463	Arm Pivot Block Assembly	2 per zone	
26B	1856802	Arm Pivot Block	2 per zone	
26C	1854902	Cam Follower	2 per zone	
26D	1854903	Jam Nut	2 per zone	
27	4516098	Seal Cap	2 per zone	
28	4524292	Wiper Seal	2 per zone	
29	4525256	O-Ring	2 per zone	
30A	4520408	Seal Cap Bracket Lt	1 per zone	
30B	4520407	Seal Cap Bracket Rt	1 per zone	
31A	4516976	Grease Bucket Support	2	
31B	8000213	Lock Washer - SPL #10X0.334X.047 SS	4	
	8000338	Washer-FLT, 7/32 X 1/2, SS	4	
	8003143	MSCR-TH-PHIL 10-24 X 1-1/4 18-8	4	
32A	4524822	Grease Bucket BA Rt	1	
32B	5424823	Grease Bucket BA Lt	1	
33	4516977	Actuator Base Brace	1 per zone	
34	4517394	Gas Inlet	1	
35	4517593	Front Heat Shield, Outer	1	
36	4517594	Front Heat Shield, Inner	1	
37	4517654	Burner Heat Shield, Lower	1	
38	4517655	Burner Heat Shield, Upper	1	

* NOT ILLUSTRATED

RECOMMENDED STOCK PARTS

GARLAND PARTS IDENTIFICATION

Gas - Xpress Grill Complete Exploded View - Model: XG36-JIB

ITEM	PART #	DESCRIPTION	QUANTITY	CRITICAL
39	Page 72	Flue Assembly	1 per zone	
40	1869301	Transformer Bracket	1	
41	4516114	Circuit Brace	1	
42	4520578	Grill Plate Thermocouple	1 per zone	C
43	1866103	Strain Relief Wire 12.5"	2	
44	1866101	Ground Wire 24"	1	

* NOT ILLUSTRATED

RECOMMENDED STOCK PARTS

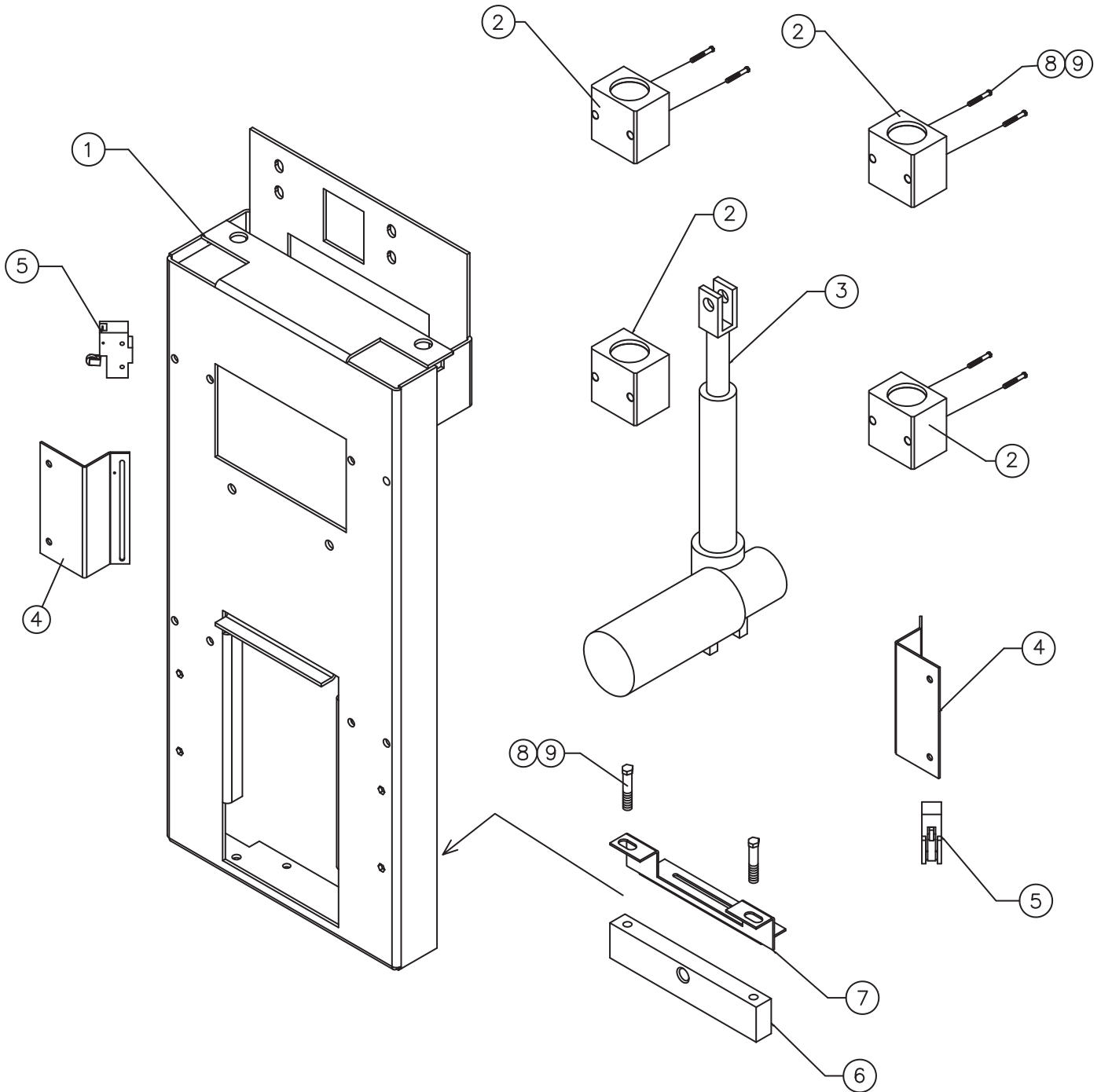

XG36-JIB#2

GARLAND PARTS IDENTIFICATION

GAS - XPRESS GRILL ACTUATOR ASSEMBLY VIEW - MODEL: XG36-JIB

ITEM	PART #	DESCRIPTION	QUANTITY	CRITICAL
1	4516080	Actuator Frame Wa	1	
2	4518156	Pillow Block Assembly	4	
3	4525541	Linear Actuator	1	C
4	1857601	Switch Bracket	2	
5	1855601	Upper/Lower Platen Limit Switch	2	C
6	4518787	Actuator Mount Block (Painted)	1	
7	4516097	Actuator Base Bracket	1	
8	8003424	1/4" – 20 X 2.250" Shoulder Bolts	8	
9	8000306	1/4" Lock Washer	8	

* NOT ILLUSTRATED

RECOMMENDED STOCK PARTS

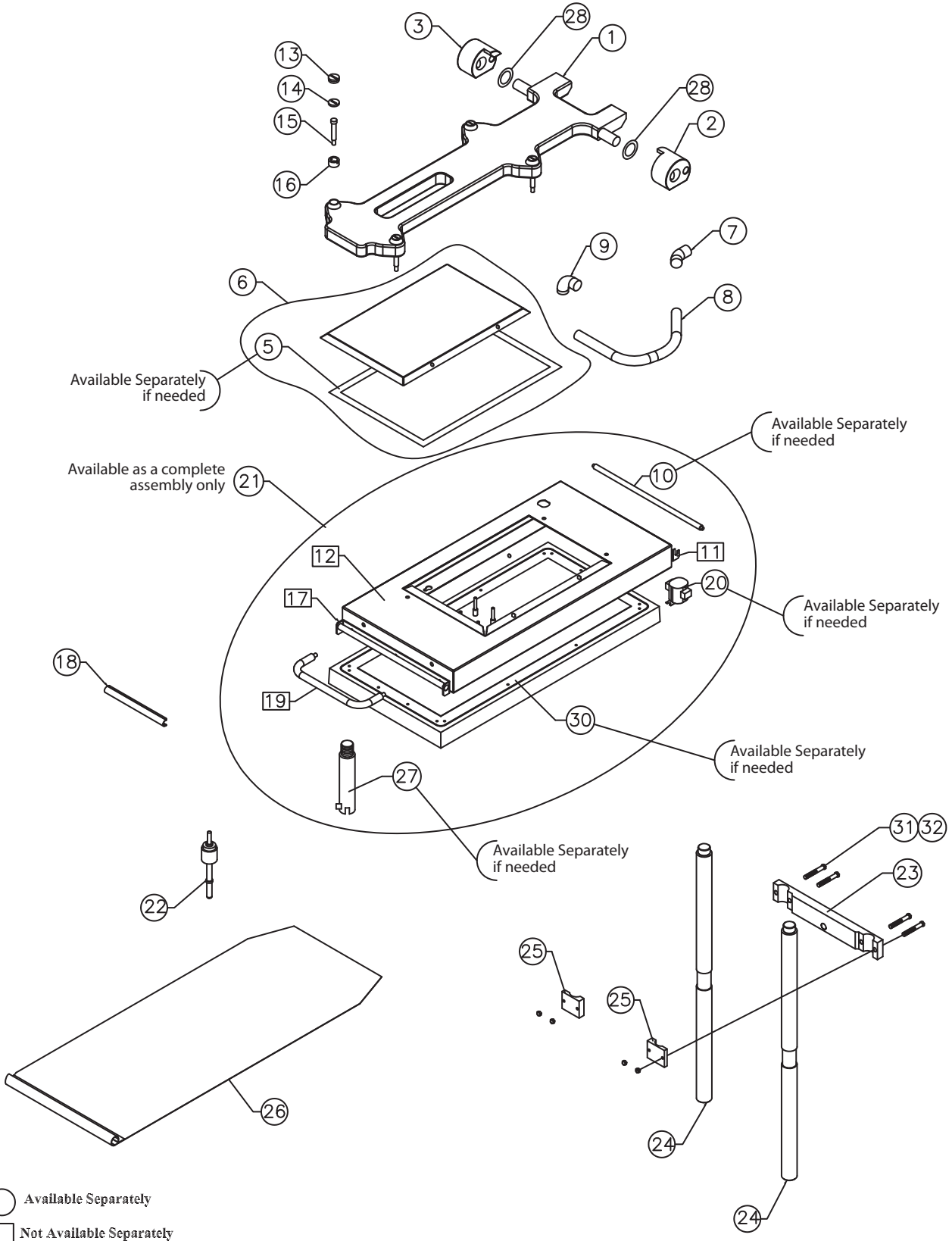

- Available Separately
- Not Available Separately

XG36 - JIB#3

GARLAND PARTS IDENTIFICATION

Gas - Xpress Grill Platen Assembly View - Model: XG36-JIB

ITEM	PART #	DESCRIPTION	QUANTITY	CRITICAL
1	4516085	Platen Arm	1	
2	4520422	Carriage Block, Assembly, Rt	1	
3	4520423	Carriage Block, Assembly, Lt	1	
5	4522581	1/16 TH Silicone Gasket	3.5 Ft	
6	4516092	Platen Lid	1	
7	4517021	3/8 Connector, 45 Deg	1	
8	4517022	Platen Conduit	1	
9	4517020	3/8 Connector, 90 Deg	1	
10	4517008	Teflon Bar, Rear	1	
11	4516094	Teflon Holder, Rear (Not Available Separately) Note: Not Field Replaceable	1	
12	4516091	Platen Cowl (Not Available Separately)	1	
13	1859102	Platen Adjuster Cap	4	
14	1859103	Platen Lock Nut	4	
15	8005401	Shoulder Bolt	4	
16	1859101	Platen Adjuster Nut	4	
17	4516093	Teflon Holder, Front (Not Available Separately) Note: Not Field Replaceable	1	
18	1851301	Teflon Clip	1	C
19	1859501	Upper Platen Handle (Not Available Separately)	1	
20	1781301	Hi Limit - Auto Reset	1	C
21	4519752	Platen Assembly Complete 208V	1	C
	4519755	Platen Assembly Complete 240V	1	C
22	1859401	Platen Thermocouple	1	C
23	4516089	Cross Member	1	
24	4516084	Actuator Shaft	2	
25	4516090	Cross Member Bracket	2	
26	1799303	Teflon Sheet	2	C
27	1859402	Grill Plate/Platen Bayonet Adapter	1	
28	1855903	Teflon Washer Small	2	
30	1937701	Goretex GSKT Tape .75W .065T	5.5 Ft.	
31	8003423	Mscr-HH-Grd5 1/4-20x1-1/4Stl 2 (to attach #23 & #25)	4	
32	8000203	Lkwshr - SPL 1/4 x 1/2 x 1/16 Stl 2P (to attach #23 & #25)	4	

* NOT ILLUSTRATED

RECOMMENDED STOCK PARTS

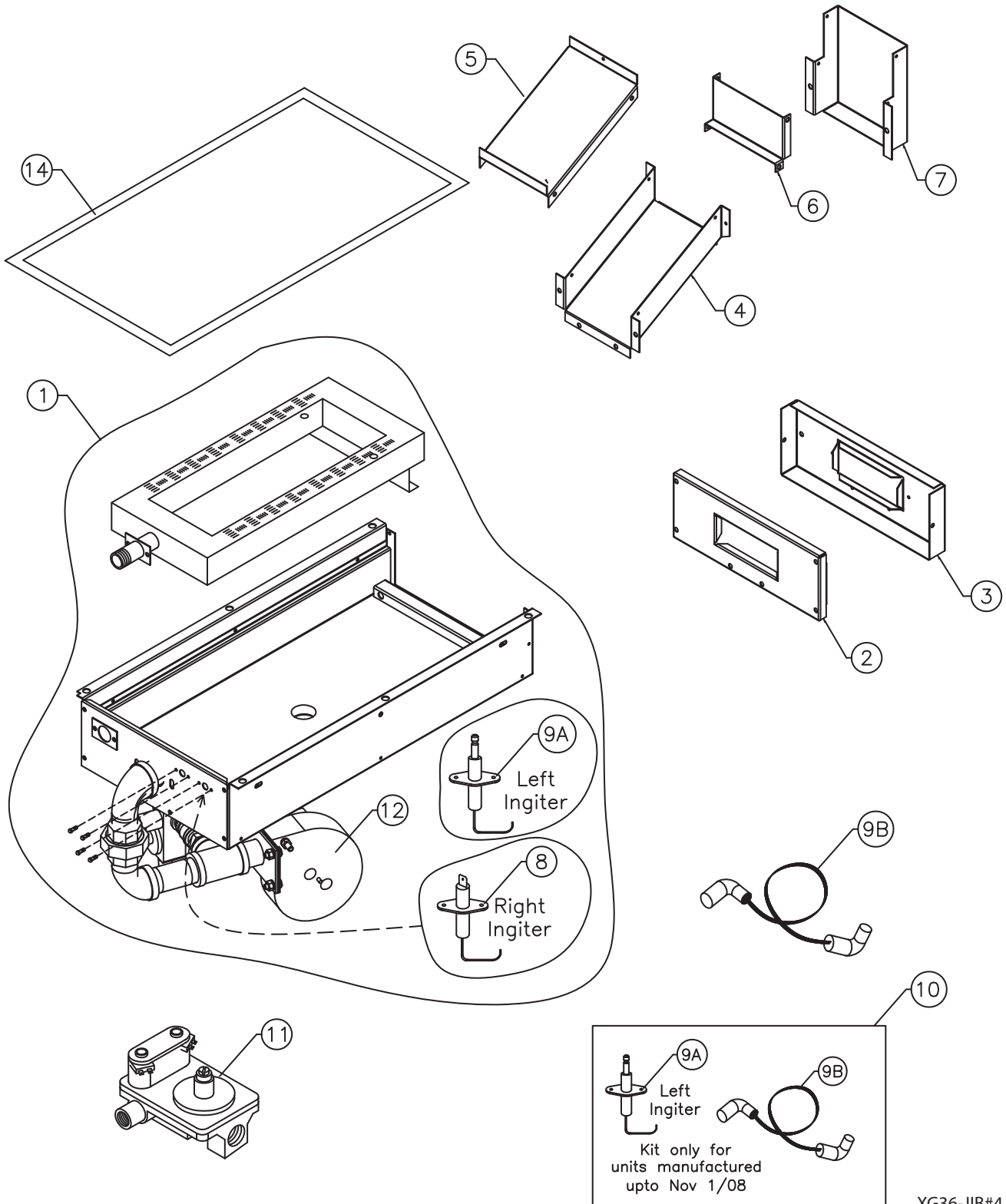

GARLAND PARTS IDENTIFICATION

Gas - Xpress Grill Burner Assembly View - Model: XG36-JIB

ITEM	PART #	DESCRIPTION	QUANTITY	UP TO	FROM	CRITICAL
1	4517403	Burner Assembly, Lp	1			C
	4517462	Burner Assembly, Nat	1			
2	4517396	Flue Box, Inner	1			
3	4517397	Flue Box, Outer	1			
4	4517398	Flue Bottom	1			
5	4517399	Flue Top	1			
6	4517401	Flue Riser, Inner	1			
7	4517400	Flue Riser, Outer	1			
8	4524066	Igniter	2 (See Note)	1-Nov-08		C
			1		2-Nov-08	
		Note: If left igniter needs replacement - order kit item# 10				
9A	4525537	Electrode Igniter - Rajah	1		2-Nov-08	C
9B	1864803	Ignition Cable	1		2-Nov-08	C
10	4525538	Service Kit Igniter & Igniter Cable - Spark Plug Type Included item # 9A & 9B Units Manufactured Up To Nov 1/08 will required Kit	1	1-Nov-08		
11	1864701	Gas Valve - Nat	1			C
12	4525845	Blower / Motor 120V	1			
14	WFT125750	1/8 x 3/4 Woven FG Tape W/PSA	5.5 Ft			

* NOT ILLUSTRATED

RECOMMENDED STOCK PARTS

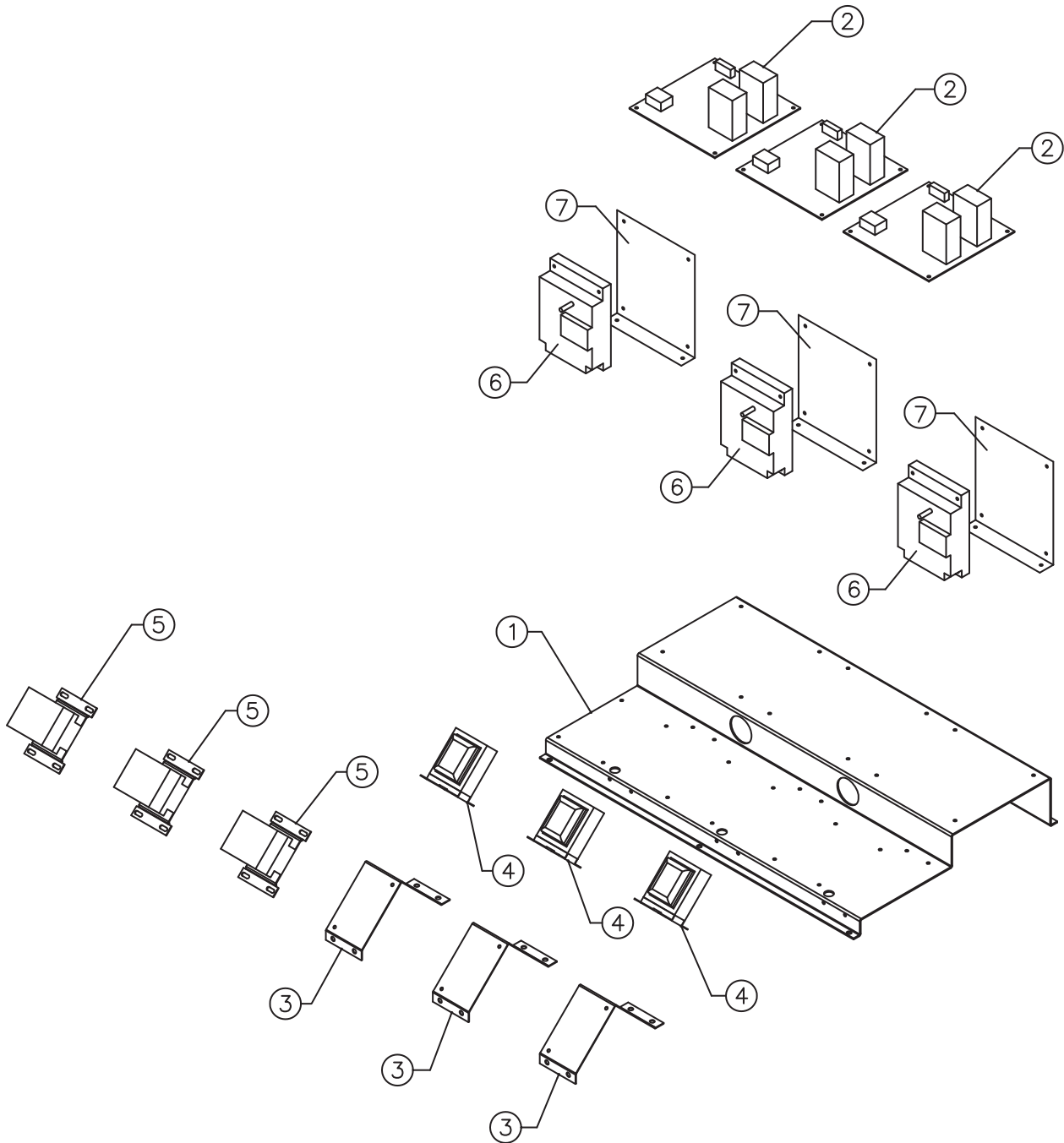

XG36 - JIB#5

GARLAND PARTS IDENTIFICATION

Gas - Xpress Grill Component Bracket Assembly View - Model: XG36-JIB

ITEM	PART #	DESCRIPTION	QUANTITY	CRITICAL
1	4516078	Component Mounting Bracket	1	
2	4516989	Motor Speed Control	3	C
3	4516079	Contactactor Bracket	3	
4	1269800	24 Volt Transformer	3	C
5	1637001	Contactactor	3	C
6	1864901	Ignition Module	3	
7	1865901	Ignition Module Bracket	3	

* NOT ILLUSTRATED

RECOMMENDED STOCK PARTS

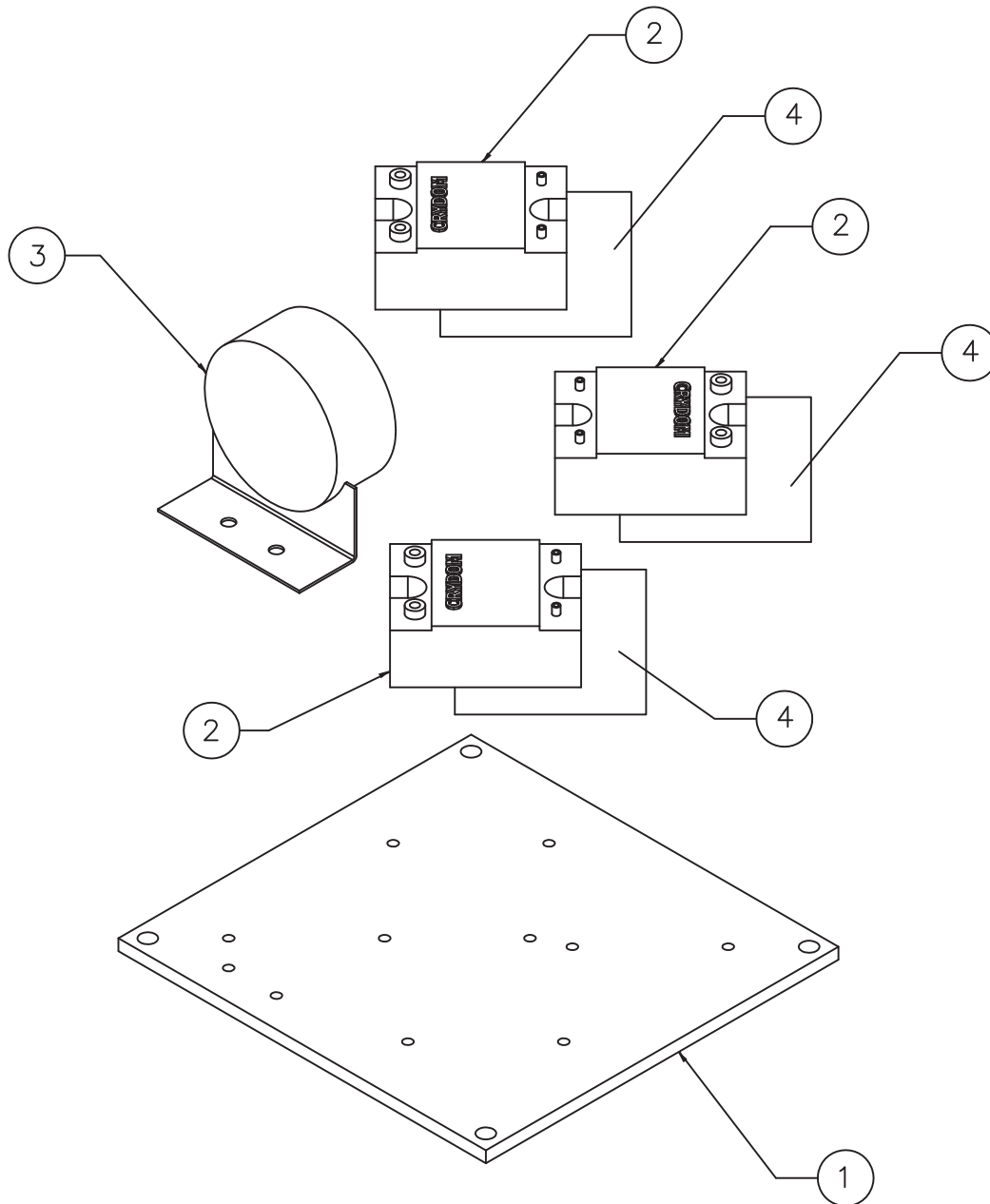

GARLAND PARTS IDENTIFICATION

Gas - Xpress Grill Heat Sink Assembly View - Model: XG36-JIB

ITEM	PART #	DESCRIPTION	QUANTITY	CRITICAL
1	4516116	Heat Sink	1 Per Zone	
2	4516988	Relay	3	C
3	4517392	Pressure Switch	1	
4	1811903	Thermal Interface MAT	3	

* NOT ILLUSTRATED

RECOMMENDED STOCK PARTS

WIRING HARNESS AND DESCRIPTION WHERE USED

GARLAND PARTS IDENTIFICATION

Gas - Xpress Grill Wire Harness And Description Where Used - Model: XG36-JIB

ITEM	PART #	DESCRIPTION & LOCATION	QUANTITY	CRITICAL
1*	1859850	Description: 120V Harness Location: Motor Speed Control, 120 volt side of 120/24 volts transformer, Power to Actuator, 120 volts terminal block.	1	C
2*	1859851	Description: CB Contactor Harness Location: Circuit Breakers, Contactors, high Voltage side of SSR's for Platens, 120 volt terminal block.	1	C
3*	1859852	Description: XMFR Harness Location: Main Power Circuit Breaker, Main Power Switch, 240/1 20 volt Transformer, 120 volt Terminal Block, Main Terminal block	1	C
4*	1859853	Description: Control Harness Location: Low Voltage side of SSR's, 24 volt out put on 120/24 volt transformer, encoder, upper/lower Limit Switches, Main Control, Motor Speed Control, Green and Black push Buttons	3	C
5*	1859854	Description: Ignition Harness Location: Pressure Switch, Ignition Module, Gas Valve, Main Control, Blower Motor, 120 volt Terminal Block.	1	C
6A*	1859855	Description: Platen Harness P1 Connector to the Platen Elements.	3	C
6B*	0007500FS	Fibreglass Sleeving Must replace with item 6A	3	C
7*	1859860	Description: Switch Harness Green and Black button Harness one per zone.	3	C
8*	1859829	Description: Contactor Jumper Harness Straight leads from terminal Block to Circuit Breakers	1	C
9*	1859810	Description: Power Switch Harness Location: Main Power Switch to Connector S3.	1	C
10*	4525505	Cord and Plug Assy, NEMA 15-50	1	

* NOT ILLUSTRATED

RECOMMENDED STOCK PARTS

GARLAND PARTS IDENTIFICATION

Gas - Xpress Grill Accessories And Tools - Model: XG36-JIB

ITEM	PART #	DESCRIPTION	QUANTITY	CRITICAL
1	4523323	Platen Adjuster Tool		
2	4525560	Teflon Tool		
3	1838701	Platen Leveling Tool CK		
4	1868201	Grill Wiper		
5	4526114	Tool Holder for Scraper		
6	4526115	Tool Holder for Wiper		
7	4526113	Tool Holder for Spatula		

* NOT ILLUSTRATED

RECOMMENDED STOCK PARTS

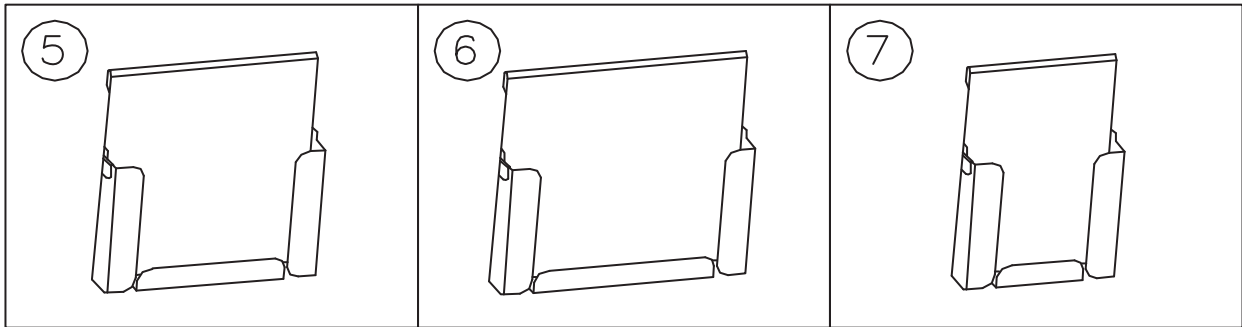
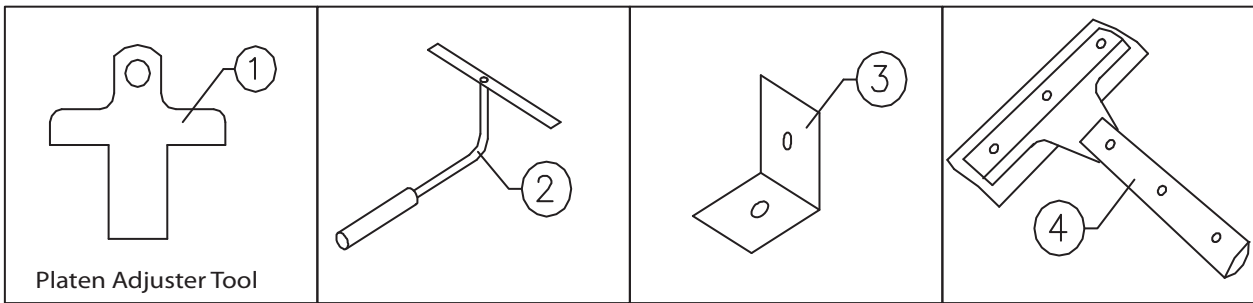

GAS TUBING,

Gas - Xpress Grill Gas Tubing - Model: XG36-JIB				
ITEM	PART #	DESCRIPTION	QUANTITY	CRITICAL
A	4517378	Tubing, Left - (Location, left zone)	1	
B	4517377	Tubing, Center - (Location, center zone)	1	
C	4517376	Tubing, Right - (Location, right zone)	1	

* NOT ILLUSTRATED

RECOMMENDED STOCK PARTS

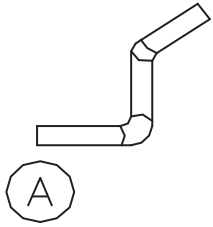
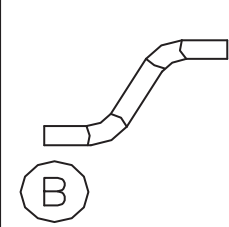
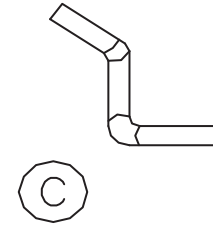
Left Zone	Center Zone	Right Zone
		

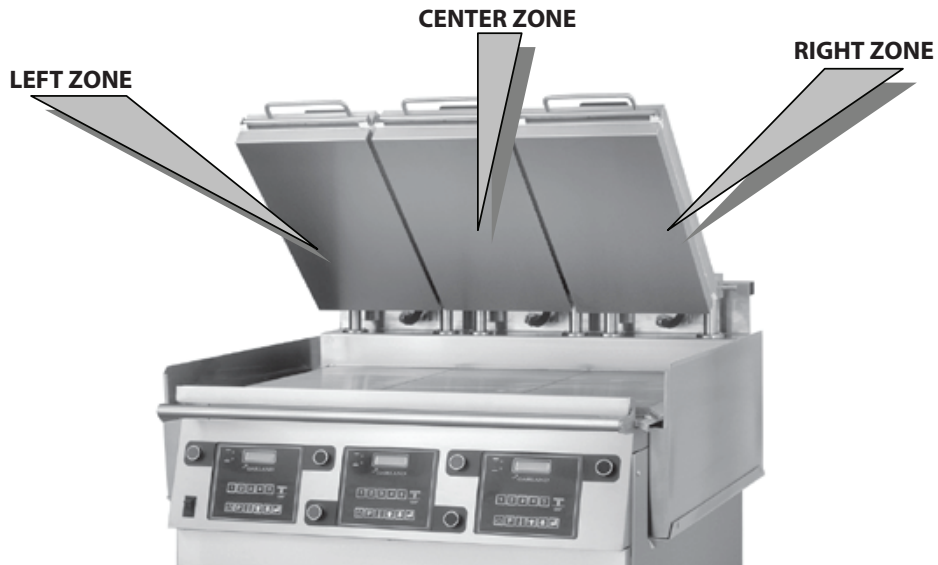

REVISION HISTORY

GARLAND PARTS IDENTIFICATION

Revision History

REV. #	PAGE #	ITEM #	NOTE	DATE
			Parts List Book Released	Oct 27/08
1	64		New Drawing	Nov 24/08
	65	3,4,5	Quantity Changed – Was 2 All Three	
		26A	Quantity Changed – Was 1 Per Zone	
		26B, 26C	Part # Changed 26B Was 1856801, 26C Was 1354902, Quantity Changed - Was 6	
		26D	Quantity Changed - Was 2	
		43	Description Changed - Was Ground Wire 12-1/2" (Strain Relief) - Quantity Changed, Was 1	
		44	New Part Number Added	
	69	2	Quantity Changed - Was 4 Per Zone	
		3	Part Number Changed - Was 1812401, Description Changed - Was Actuator	
	70		New Drawing	
	71	5	Description Changed - Was Silicone Gasket Quantity Changed - Was 1	
		21	Part # Deleted - Was 4519753 Platen Assembly Complete 220V	
		26	Quantity Changed - Was 1	
		30	New Part Number	
			Item 33 Moved to Page 18	
		28	Quantity Changed Was 2 Per Zone	
		31,32	Quantity Changed Was 4 Per Zone	
	72		New Drawing	
73	10	Part Number Changed - Was 4517967		
	14	New Part Number Added		
78		New Page With Wiring Harness		
79		New Page – Accessories And Tubing Transferred To This Page		
2	65	28	Part number changed - was 4517006	Dec 11/08
	72		New Drawing	
	73		Up To & From Columns Added	
		8	Note Added Under Description And Dates	
		9A	Item Number Changed - Was 9	
		9B	Item Number Changed - Was 10	
		10	New Part Number Added	
		13	Item # Removed - Was 13511 (Screw, Hxsltcsr 8-32 X .312) Qty: 4	
74		New Drawing		
75	7	New Part Number Added		
79	2	Part Number Changed - Was 4525561		
3	70		New Drawing	Feb 06/09
	71	11,17	Note Added	
	79	4,5,6,7	Part Number Added	
	80		New Page Added – Content was on Page 79	
	63		Index Updated, Gas Tubing, Page 80 Added	

WIRING DIAGRAM

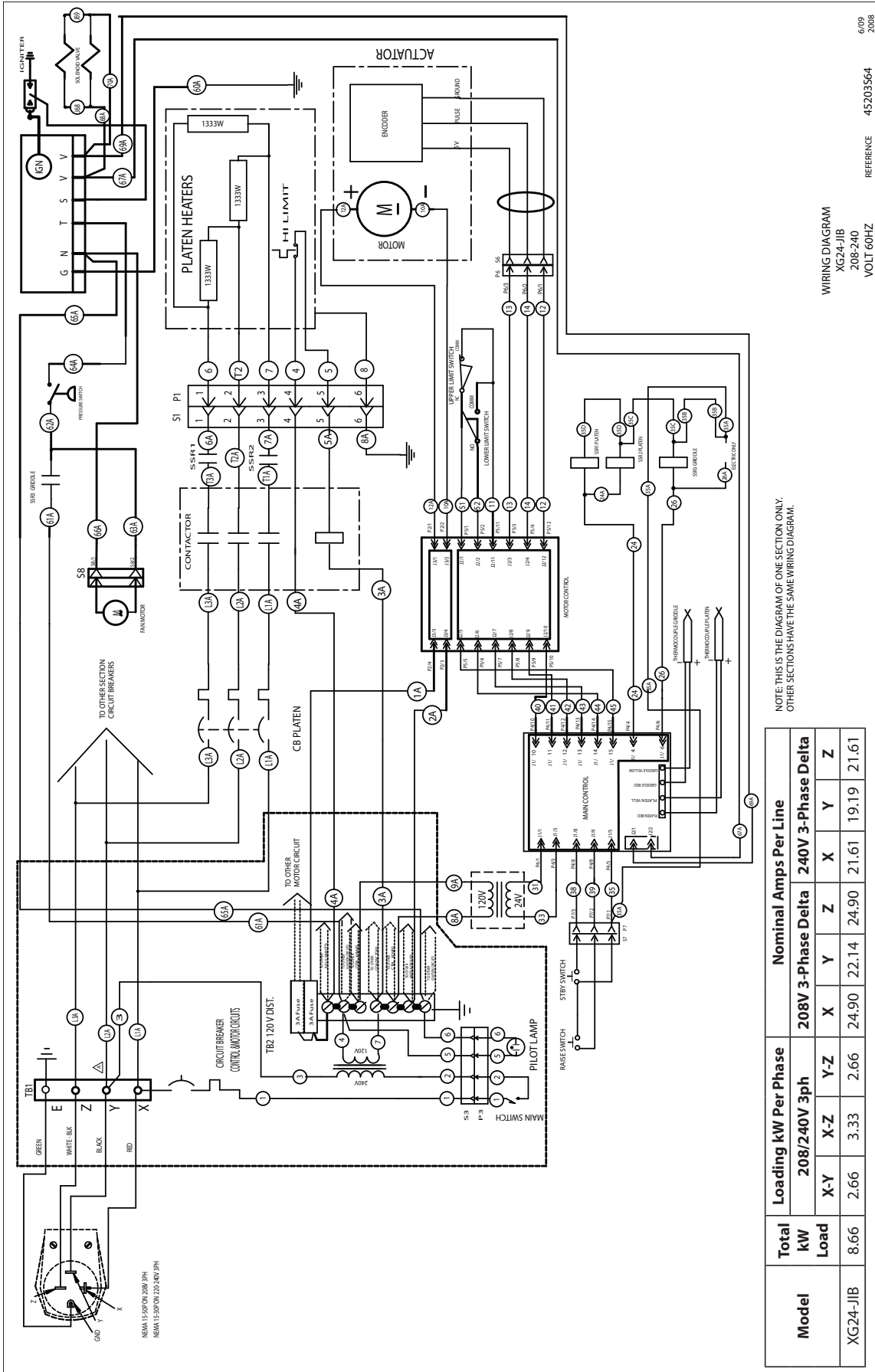

WIRING DIAGRAM
 XG24-JIB
 208-240
 VOLT 60HZ

6/09
 2008

REFERENCE 45203564

NOTE: THIS IS THE DIAGRAM OF ONE SECTION ONLY.
 OTHER SECTIONS HAVE THE SAME WIRING DIAGRAM.

Model	Loading kW Per Phase		Nominal Amps Per Line					
	208V/240V 3ph		240V 3-Phase Delta					
	X-Y	X-Z	Y	Z	X			
XG24-JIB	2.66	3.33	24.90	22.14	24.90	21.61	19.19	21.61

WIRING DIAGRAM

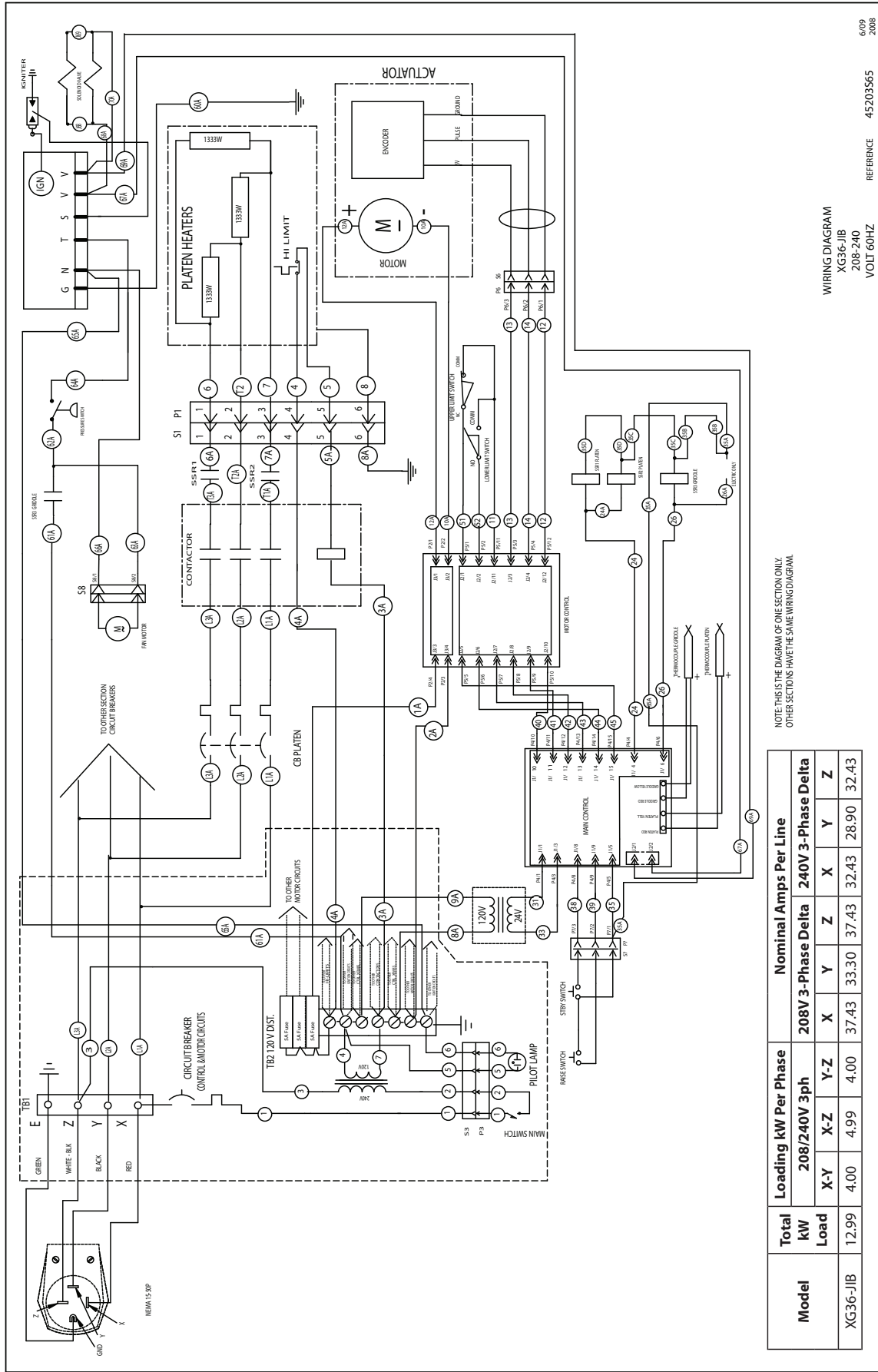

NOTE: THIS IS THE DIAGRAM OF ONE SECTION ONLY.
OTHER SECTIONS HAVE THE SAME WIRING DIAGRAM.

Model	Loading kW Per Phase		Nominal Amps Per Line		
	208V 3-Phase	240V 3-Phase	208V 3-Phase Delta	240V 3-Phase Delta	
XG36-JIB	X-Y	4.00	37.43	33.30	37.43
	Y-Z	4.00	37.43	33.30	37.43
	Z	4.00	37.43	33.30	37.43

WIRING DIAGRAM
XG36-JIB
208-240
VOLT 60HZ
REFERENCE 45203565
6/09
2008

CONTROLLER MENU ITEMS

The following table list menu items defaulted in the main controller. To reprogram any function or feature below, see programming section.

Jack in the Box Menu Items									
	1	2	3	4	5	6	7	8	Step Process Screen Display
	Menu Items		Platen						
	Menu Name	Cook Time	Yes/No	Top Temp	Bottom Temp	Gap Setting	Assign to #	Button Insignia	
Fajitas	Fajitas	1:16	yes	425F	335F	0.300	1	FAJI	
Sausage	Sausage	2:00	yes	425F	335F	0.380	2	SAUS	
Regular	Regular	1:15	yes	425F	335F	0.300	3	REG	
Jumbo	Jumbo	2:50	yes	425F	335F	0.470	4	JMBO	
Chicken Filet	Chicken	1:40	yes	425F	335F	0.460	5	CHIK	
Sirloin Patties	Sirloin	2:00	yes	425F	335F	0.600	6	SIRLOIN	
Chicken Tenderloins	Chicken tendeln	1:27	yes	425F	335F	0.430	7	CHK STRP	
Grilled Onions	Onions	3:00	no	425F	335F	FLAT	8	ONIONS	
							9	*LTO	

*LTO = Limited Time Offer = presently left open

TEMPERATURE CONVERSION (F / C)

C	F	C	F	C	F	C	F	C	F
27	80	54	128	80	176	107	224	134	272
27	81	54	129	80	177	107	225	134	273
28	82	55	130	81	178	108	226	134	274
28	83	55	131	81	179	108	227	135	275
29	84	56	132	82	180	109	228	135	276
30	85	56	133	83	181	110	229	136	277
30	86	57	134	83	182	110	230	137	278
31	87	57	135	84	183	111	231	137	279
31	88	58	136	84	184	111	232	138	280
32	89	59	137	85	185	112	233	138	281
32	90	59	138	85	186	112	234	139	282
33	91	60	139	86	187	113	235	139	283
33	92	60	140	86	188	114	236	140	284
34	93	61	141	87	189	114	237	141	285
34	94	61	142	88	190	115	238	141	286
35	95	62	143	88	191	115	239	142	287
36	96	62	144	89	192	116	240	142	288
36	97	63	145	89	193	116	241	143	289
37	98	63	146	90	194	117	242	143	290
37	99	64	147	90	195	117	243	144	291
38	100	64	148	91	196	118	244	144	292
38	101	65	149	91	197	119	245	145	293
39	102	65	150	92	198	119	246	146	294
40	103	66	151	93	199	120	247	146	295
40	104	66	152	94	200	120	248	147	296
41	105	67	153	94	201	121	249	147	297
41	106	68	154	94	202	121	250	148	298
42	107	68	155	95	203	122	251	148	299
42	108	69	156	95	204	122	252	149	300
43	109	70	157	96	205	123	253	149	301
43	110	70	158	97	206	124	254	150	302
44	111	71	159	97	207	124	255	151	303
44	112	71	160	98	208	125	256	151	304
45	113	72	161	98	209	125	257	152	305
45	114	72	162	99	210	126	258	152	306
46	115	73	163	99	211	126	259	153	307
46	116	74	164	100	212	127	260	153	308
47	117	74	165	101	213	127	261	154	309
48	118	75	166	101	214	128	262	154	310
48	119	75	167	102	215	128	263	155	311
49	120	76	168	102	216	129	264	156	312
49	121	76	169	103	217	130	265	156	313
50	122	77	170	103	218	130	266	157	314
50	123	77	171	104	219	130	267	157	315
51	124	78	172	105	220	131	268	158	316
52	125	78	173	105	221	131	269	158	317
52	126	79	174	106	222	132	270	159	318
53	127	79	175	106	223	133	271	159	319

C	F	C	F	C	F	C	F	C	F
160	320	187	368	213	416	240	464	267	512
161	321	187	369	214	417	241	465	267	513
161	322	188	370	214	418	241	466	268	514
162	323	188	371	215	419	242	467	268	515
162	324	189	372	216	420	242	468	269	516
163	325	189	373	216	421	243	469	269	517
163	326	190	374	217	422	243	470	270	518
164	327	191	375	217	423	244	471	271	519
164	328	191	376	218	424	244	472	271	520
165	329	192	377	218	425	245	473	272	521
166	330	192	378	219	426	246	474	272	522
166	331	193	379	219	427	246	475	273	523
167	332	193	380	220	428	247	476	273	524
167	333	194	381	221	429	247	477	274	525
168	334	194	382	221	430	248	478	274	526
168	335	195	383	222	431	248	479	275	527
169	336	196	384	222	432	249	480	276	528
169	337	196	385	223	433	249	481	276	529
170	338	197	386	223	434	250	482	277	530
171	339	197	387	224	435	241	483	277	531
171	340	198	388	224	436	241	484	278	532
172	341	198	389	225	437	252	485	278	533
172	342	199	390	226	438	252	486	279	534
173	343	199	391	226	439	253	487	279	535
173	344	200	392	227	440	253	488	280	536
174	345	201	393	227	441	254	489	281	537
174	346	201	394	228	442	254	490	281	538
175	347	202	395	228	443	255	491	282	539
176	348	202	396	229	444	256	492	282	540
176	349	203	397	229	445	256	493	283	541
177	350	203	398	230	446	257	494	283	542
177	351	204	399	231	447	257	495	284	543
178	352	204	400	231	448	258	496	284	544
178	353	205	401	232	449	258	497	285	545
179	354	206	402	232	450	259	498	285	546
179	355	206	403	233	451	259	499	286	547
180	356	207	404	233	452	260	500	287	548
181	357	207	405	234	453	261	501	287	549
181	358	208	406	234	454	261	502	288	550
182	359	208	407	235	455	262	503	288	551
182	360	209	408	236	456	262	504	289	552
183	361	209	409	236	457	263	505	290	553
183	362	210	410	237	458	263	506	290	554
184	363	211	411	237	459	264	507	291	555
184	364	211	412	238	460	264	508	291	556
185	365	212	413	238	461	265	509	292	557
186	366	212	414	239	462	266	510	292	558
186	367	213	415	239	463	266	511	293	559

 **Garland**[®]

 **press grill**