



GX Series Infra-Red Cheesemelter

Item: _____

Quantity: _____

Project: _____

Approval: _____

Date: _____

Models:

GXCM24

GXCM36

GXCM60

GXCM72



Standard Features:

- Infrared burners
- Constant pilot for instant lighting
- Stainless steel front, side, and top
- Removable, chrome-plated wire rack
- Fiberglass insulated sides, bottom, and back
- 24" (610mm) to 72" (1829mm) widths available
- Wall and counter top models
- 3/4" gas regulator
- One year parts and labor

Optional Features:

- Extra shelves
- Wall mount kit

Specification:

Shall be Garland GX Series Cheesemelter. Unit shall be range, wall, or counter mounted. Unit to be available in widths from 24" (610mm) to 72" (1829mm) x 17 5/8" (448mm) deep x 18 3/4" (476mm) high. Finish is to be stainless steel front, sides, and top. Shelves to be removable round stock chrome plated.



GX Series Infra-Red Cheesemelter

Garland Commercial Industries, LLC
 185 East South Street
 Freeland, PA 18224
 Phone: (570) 636-1000
 Fax: (570) 636-3903

Garland Commercial Ranges Ltd
 1177 Kamato Road,
 Mississauga, Ontario
 L4W 1X4 CANADA
 Phone: 905-624-0260
 Fax: 905-624-5669



Model #	Dimensions: In. (mm)			No. of Burners	Total BTU*
	Width (A)	Depth	Height		
GXCM24	24(610)	17-5/8(447)	18-3/4(476)	1	20,000
GXCM36	36(914)	17-5/8(447)	18-3/4(476)	1	30,000
GXCM60	60(1524)	17-5/8(447)	18-3/4(476)	2	50,000
GXCM72	72(1829)	17-5/8(447)	18-3/4(476)	3	60,000

*** Natural and Propane Gas**

Manifold Operating Pressure All Models			
Natural Gas		Propane	
"WC	Mbar	"WC	Mbar
5	12.5	10	25

Shipping Information		
Model #	Weight Lb/Kg	Cu Ft
GXCM24	145/66	9
GXCM36	185/84	13
GXCM60	265/120	21
GXCM72	300/136	25

Many local codes exist and it is the responsibility of the owner and installer to comply with those codes.

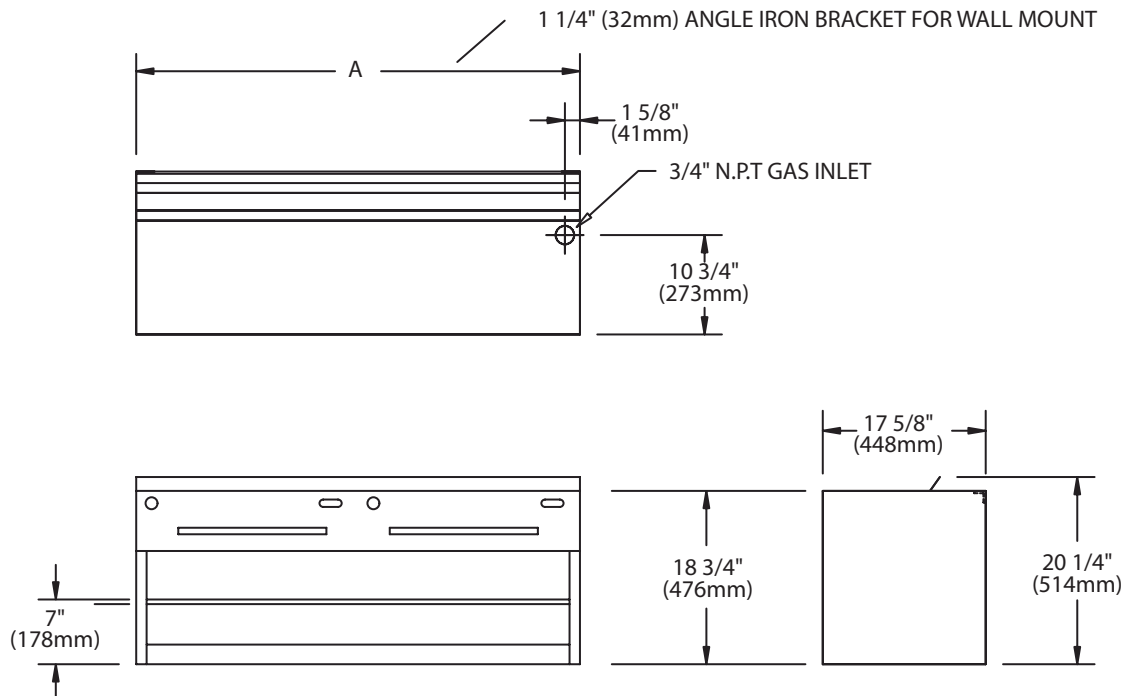

Garland/U.S. Range products are not approved or authorized for home or residential use, but are intended for commercial applications only. Garland / U.S. Range will not provide service, warranty, maintenance or support of any kind other than in commercial applications.

Form# GXCM (01/20/10)