



# Electric Counter Top Pizza Oven w/2 Hearths

Item: CPO-ES-12H

Quantity: \_\_\_\_\_

Project: \_\_\_\_\_

Approval: \_\_\_\_\_

Date: \_\_\_\_\_

Models:

CPO-ES-12H



Model CPO-ES-12H

### Standard Features:

- Incoloy tubular heating elements
- 1.8kW (120V), 2.85kW (208V/240V)
- 650°F, (343°C), adjustable, electro-mechanical thermostats, one per oven cavity
- One fifteen minute mechanical timer per oven cavity
- 3" crown heights
- Oven ready light indicates oven has reached selected temperature, one per oven cavity
- 1-1/2" thick insulation in walls, top, and doors
- 2 removable baking hearths
- All stainless steel finish
- Standard with 6-ft. (1.8m) long cord and plug
- 120, 208 or 240 volts (please specify at time of order), single phase only
- One-year parts and labor warranty
- 4" adjustable legs

### Optional Features:

60-minute timer

### Capacity:

- Two (2) 20" pre-baked crust or fresh dough pizzas, (not designed for pan pizza)

### Specifications:

Garland Model Number CPO-ES-12H, electric counter top pizza oven. Compact 22-1/2"W x 23-1/2"D size includes a two decks with hearths. Stainless steel exterior. 650°F, (343° C) adjustable electromechanical thermostat and mechanical 15-minute timer. 120, 208, or 240 volt (please specify at time of order), available in single phase only. **Ideal for pre-baked dough.**



Electric Counter Top Pizza Oven w/2 Hearths

Electrical Specifications					
Voltage	Phase	kW	Nominal Amperes	NEMA Plug	Connection Type
120	1	1.8	15.0	5-15P	6' Line Cord
208	1	2.85	13.7	6-15P	6' Line Cord
240	1	2.85	11.9	6-15P	6' Line Cord

Dimensions					Clearances			
Exterior			Interior (hearth area)		Installation		Entry	
H	W	D	W	D	Sides	Rear	Crated	Uncrated
17-1/2" (445mm)	22-1/2" (572mm)	23-1/2" (597mm)	18-1/4" (464mm)	18-1/4" (464mm)	1" (25mm)	1" (25mm)	32" (813mm)	27-1/2" (699mm)

Shipping	
Cu Ft	Weight Lb/Kg
8.2	127/58

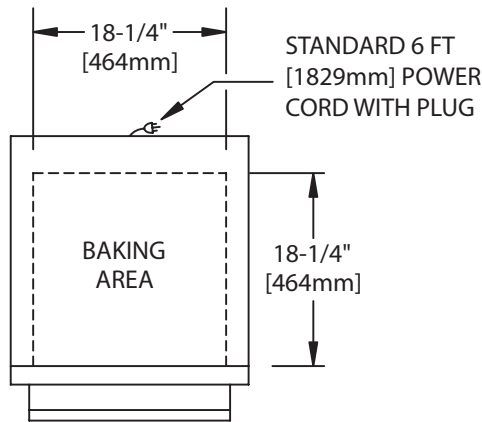

TOP VIEW

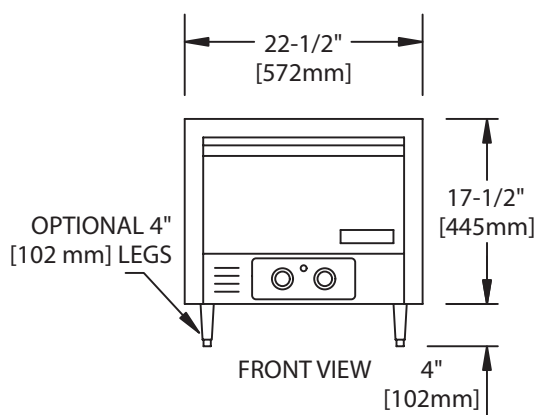

FRONT VIEW

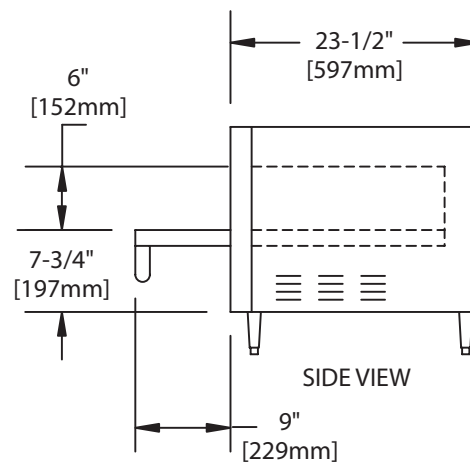

SIDE VIEW

Garland products are not approved or authorized for home or residential use, but are intended for commercial applications only. Garland will not provide service, warranty, maintenance or support of any kind other than in commercial applications.

CPOES12 (07/25/11)