



# Master Half-Size Electric Convection Oven

Item: \_\_\_\_\_  
 Quantity: \_\_\_\_\_  
 Project: \_\_\_\_\_  
 Approval: \_\_\_\_\_  
 Date: \_\_\_\_\_

Master Half-Size Electric Convection Oven

Models:

- MCO-E-5       MCO-E-25



Model MCO-E-5

NOTE: Ovens supplied with casters must be installed with an approved restraining device.

### Standard Features:

- Master 200 Solid State Control with 150° (66°C) to 500°F (260°C) temperature range
- 2-speed fan control (high & low) and 1/4 HP fan motor
- 208 or 240 volt, single or three phase (please specify)
- Total of 5.6 kW elements per oven cavity
- Stainless steel front, sides, and top
- Single door with double pane thermal window
- 6" (152mm) stainless steel legs
- Porcelain enameled oven interior with coved corners
- 5 chrome plated oven racks on 9-position rack guides
- Double deck models available -Suffix 25
- 1 year limited parts & labor warranty (USA & Canada only)
- 5 year limited door warranty, excluding window (USA & Canada only)

### Optional Features:

- Master 450 Electronic Control with Cook-N-Hold
- 7.5 kW elements
- Extra oven racks
- Stainless steel main back
- Solid stainless steel door, (no charge)
- Stainless Steel open base (34-1/2" (876mm) high) with rack guides, shelf, and square tubular legs - for extra rack/pan storage
- Stainless Steel open base (34-1/2" (876mm) high) with rack guides, shelf, and casters - for extra rack/pan storage
- 14" (356mm) NSF-approved stainless steel legs, (for double-deck applications only)
- Deck fasteners (SS flanged feet)
- Cord and plug set
- 50 cycle components & export voltage
- Swivel casters w/front brakes, (for double-deck applications only)

### Specifications:

Garland Master Half-Size electric convection oven. 5.6 kW/ cavity, 1/4 HP fan motor with two-speed control. Porcelain enameled oven interior with coved corners, 5 oven racks and 9-position rack guides, measures 15-1/2" (470mm)W x 20" (508mm)H x 21-1/8" (536mm)D. Stainless steel front, top, and sides. UL, CUL and NSF Listed.



**Garland**  
 1333 East 179th Street  
 Cleveland, Ohio 44110  
 Phone: 800-424-2411  
 Fax: 800-624-0218

**Garland Commercial Ranges Ltd**  
 1177 Kamato Road,  
 Mississauga, Ontario  
 L4W 1X4 CANADA  
 Phone: 905-624-0260  
 Fax: 905-624-5669



Model #	Interior Dimensions (per deck)			Ship Wt. Lbs/Kg	Ship Cu Ft
	W	H	D		
MCO-E-5	15-1/2" (393mm)	20" (510mm)	21" (525mm)	290/130	38.5
MCO-E-25	15-1/2" (393mm)	20" (510mm)	21" (525mm)	580/260	77

Package	Total kW	Nominal Amperes Per Line							
		208V/1Ph	240V/1Ph	208V/3Ph			240V/3Ph		
				X	Y	Z	X	Y	Z
Standard	5.6	26	22	23	12	14	20	12	14
Option	7.5	37	32	22	21	22	20	18	19

Electrical specifications include motor requirements.  
 Other voltage options available upon request:  
 220/380 4-wire 50Hz  
 240/415 4-wire 50Hz  
 NOTE: Double decks require 2 power supplies please specify electrical characteristics when ordering.

Installation Notes:			
Combustible Wall Clearances			
Sides	2" (51mm)	Back	0" (0mm)
Entry Clearance			
Crated		Uncrated	
37" (940mm)		31" (787mm)	

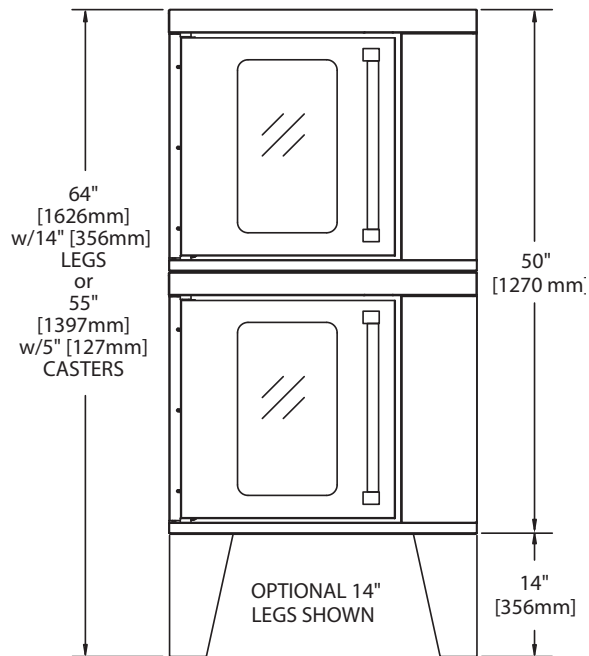
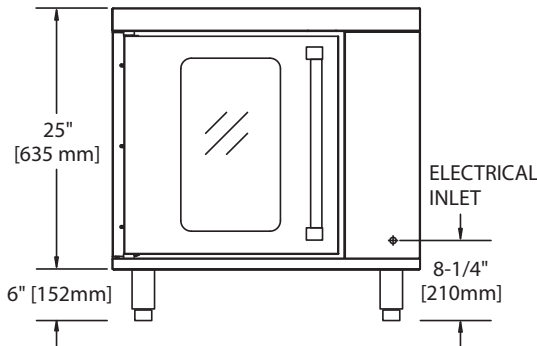
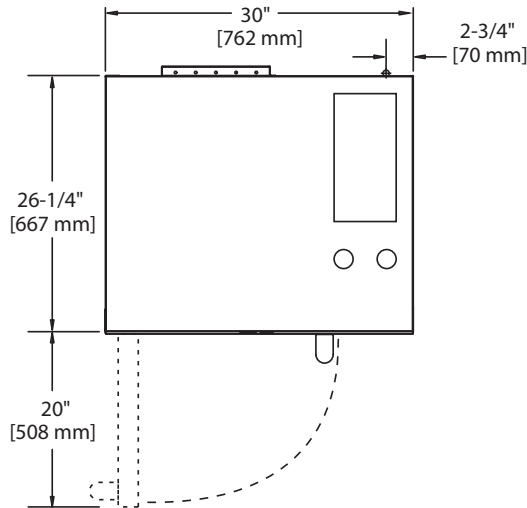

Form# MCO-E-5/25 (02/29/08)