

VERIFY ALL PARTS ARE PRESENT BEFORE BEGINNING ASSEMBLY.

PARTS LIST

4	8000310	WSHR FLT STL 3/8X1/16	16
3	8003415	MSCR-HH-STL 3/8-16X3/4	16
2	1236100	SQUARE FOOT INSERT CHROME PLATE	4
1	1793999	12" LEG W/A SS	4
	1793998	12" LEG W/A GG	4
ITEM	PART NUMBER	DESCRIPTION	QTY

* 1953207 ONLY

* 1953206 ONLY

INSTRUCTIONS

- 1 - LAY THE UNIT ON THE OVEN SIDE OPPOSITE THE CONTROL PANEL, PREFERABLY ON CARDBOARD OR A BLANKET TO PREVENT SCRATCHING THE OVEN SIDE.
- 2 - LOCATE THE CORRECT MOUNTING HOLES IN THE BOTTOM OF THE UNIT.
- 3 - ATTACH THE LEGS TO THE MAIN BOTTOM OF THE UNIT USING (4) OF THE HEX HEAD MACHINE SCREWS AND (4) WASHERS PER LEG.
- 4 - INSERT PART #1236100 INTO THE LEGS.
- 5 - TIGHTEN ALL FASTENERS BEFORE STANDING UNIT ON LEGS.

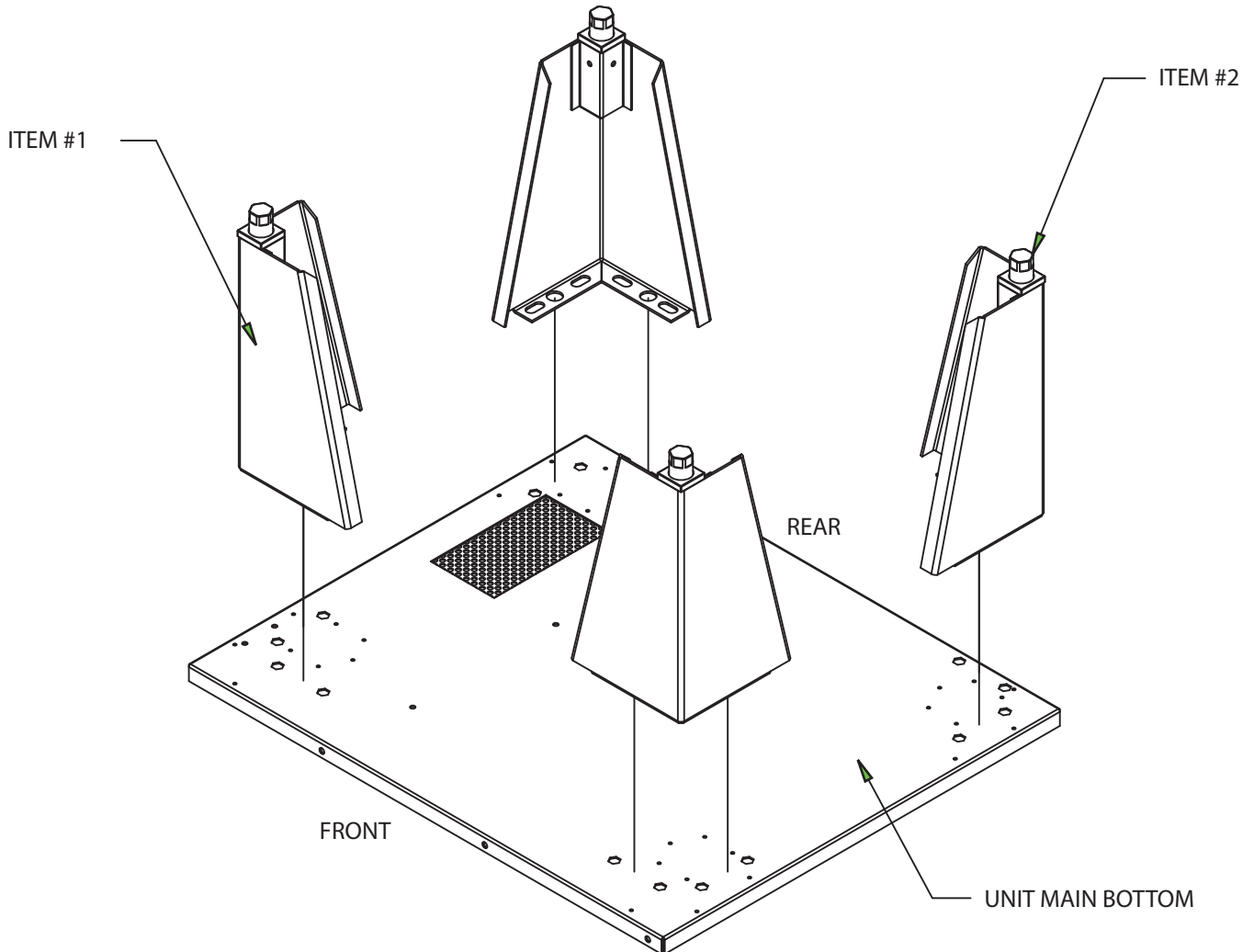

** VIEW ILLUSTRATING UNIT UPSIDE DOWN **