

VERIFY ALL PARTS ARE PRESENT BEFORE BEGINNING ASSEMBLY.

### PARTS LIST

3	8002413	ES-GRIP HEX HEAD SMS	16
2	1027801	5" SWIVEL CASTER WITH BRAKE	2
1	1027800	5" SWIVEL CASTER	2
ITEM	PART NUMBER	DESCRIPTION	QTY

**\*\*NOTE\*\*** CASTERS SHOULD BE USED ONLY ON BOTTOM DECK OF DOUBLE STACKED UNITS.  
CASTERS NOT FOR USE ON SINGLE UNITS.  
FOR UNITS PRODUCED WITHOUT (4) MOUNTING HOLES, YOU WILL NEED TO DRILL  
(2) HOLES FOR THE OPPOSITE SIDE OF THE CASTER.  
USE THE FOLLOWING HOLE PATTERN: 1-3/4 x 1-15/16.

### INSTRUCTIONS

- 1 - LAY THE UNIT ON THE OVEN SIDE OPPOSITE THE CONTROL PANEL, PREFERABLY ON CARDBOARD OR A BLANKET TO PREVENT SCRATCHING THE OVEN SIDE.
- 2 - LOCATE THE CORRECT MOUNTING HOLES BETWEEN THE CASTERS AND THE BOTTOM OF THE UNIT.
- 3 - ATTACH THE CASTERS TO THE MAIN BOTTOM OF THE UNIT USING (4) OF THE HEX HEAD SHEETMETAL SCREWS PER CASTER.
- 4 - TIGHTEN ALL FASTENERS BEFORE STANDING UNIT ON THE CASTERS.

(2) HOLES DISCUSSED  
IN ABOVE NOTES  
TYPICAL IN (4) PLACES

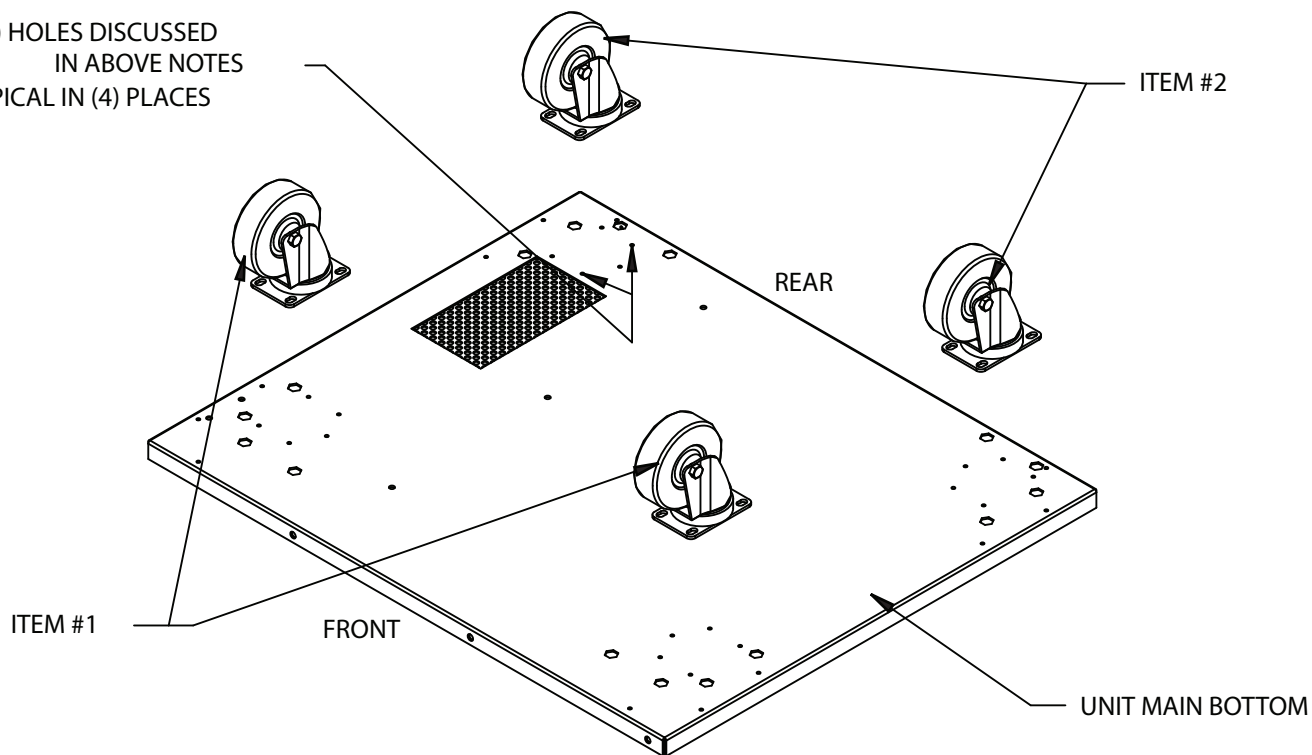

**\*\* VIEW ILLUSTRATING UNIT UPSIDE DOWN \*\***