



36 E Series Heavy Duty Range Match Fryer

Item: _____
 Quantity: _____
 Project: _____
 Approval: _____
 Date: _____

36 E Series Heavy Duty Range Match Fryer

Models:

- 36ES11 36ES11-SF

Electric 18" Wide,
30 Pound Capacity Fryer



Standard Features:

- Stainless steel front and sides
- 12kW (36ES11) & 16kW (36ES11-SF) versions available
- 30 Lb. (14kg) shortening capacity, 1 piece deep drawn, heavy gauge nickel-plated steel tank equipped with lift handles and 1" (25mm) drain valve located at the bottom
- 2 chrome wire baskets
- Electromechanical thermostat with temperature control range of 200°F (93°C) to 375°F (190°C)
- Incoloy sheath heating elements that swing up out of the way for tank removal
- Storage cabinet with door; comes with slides for optional additional fry-tank
- 6" (152mm) adjustable chrome plated legs (NSF)
- 1 Year limited parts & labor (USA & Canada)

Optional Features:

- Stainless steel main back
- Stainless steel tank cover
- Fish plate
- Extra fry tank
- Extra fry tank with 1" (25mm) drain valve
- 6" (152mm) adjustable stainless steel legs
- High voltage 460V
- 4 Swivel casters complete with front brakes
- Marine accessories of hand rails, and deck fasteners

NOTE: Fryers supplied with casters must be installed with an approved restraining device.

Specification:

Heavy-duty range match fryer with 30 Lb. (14kg) shortening capacity. One piece deep drawn, nickel plated fry tank complete with lift handles. An 1" (25mm) drain valve is located at the bottom of the tank. Incoloy sheath elements swing up and out of the way for easy removal of the fry tank. The cabinet is designed with slides to accept an optional additional fry tank. Stainless steel front and sides. Model 36ES11 is rated 12.0kW and 36S11-Sf 16.0 kW. Fryers are available with casters or for dais mount.

NOTE: The models shown above may be paired together to form a common unit. They may be paired with a frymate model or may be set up as fry-stations of two fryers with a frymate unit between them. These fryers are designed to battery with 36E series heavy-duty ranges.



Model	Total KW	Three Phase KW per Phase			Nominal Amperes Per Line											
					1 Phase			Three Phase								
		208, 240, 460			208	240	460	208			240			460		
		X-Y	Y-Z	X-Z				X	Y	Z	X	Y	Z	X	Y	Z
36ES11	12	4	4	4	58	51	26	33	33	33	30	30	30	15	15	15
36ES11-SF	16	4.5	4.5	7.0	77	68	35	49	38	49	43	33	43	22	17	22

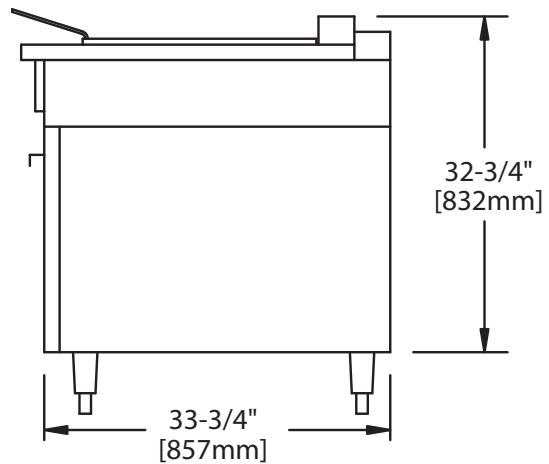
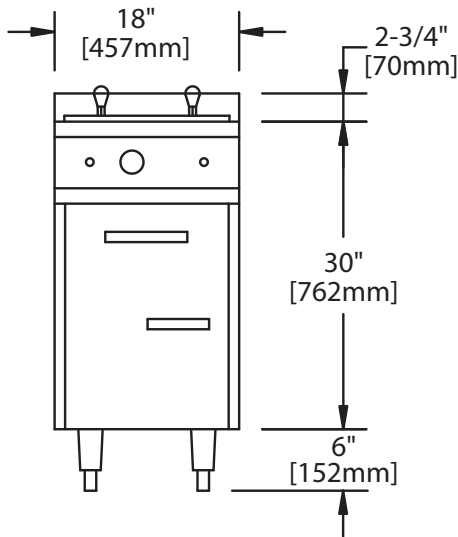
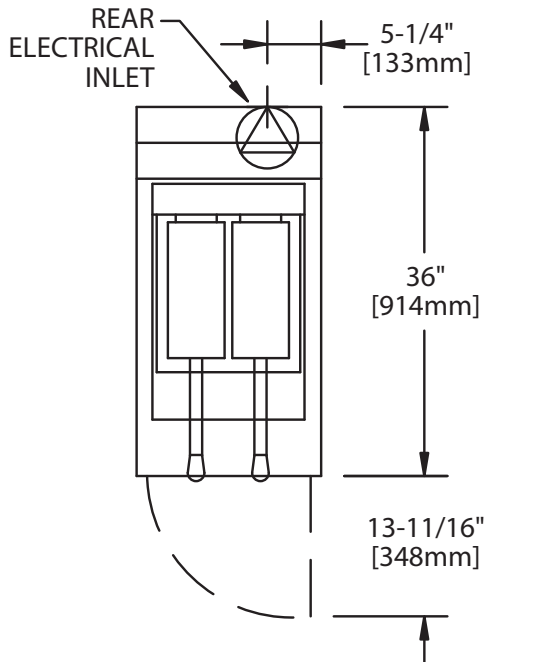

Model	Shipping Information	
	WT Lbs/Kg	Cu Ft
36ES11	265/120	25
36ES11-SF	275/125	25

Available Voltages: 208 VAC (197-219); 240 VAC (220-240); 460 VAC (440-480).

When ordering specify voltage and phase.

Garland products are not approved or authorized for home or residential use, but are intended for commercial applications only. Garland will not provide service, warranty, maintenance or support of any kind other than in commercial applications.

Form# 36ES11 (08/17/11)