



36 E Series Spreader Cabinet

Item: _____

Quantity: _____

Project: _____

Approval: _____

Date: _____

36 E Series Spreader Cabinet

Models:

36ESC12

36ESC18

36ESC24

36ESC36



Model 36ESC18

Standard Features:

- Stainless steel front with black powder coat epoxy sides
- Stainless steel front rail
- Stainless steel spreader work top
- 6" (152mm) adjustable chrome plated legs (NSF)
- Low profile stainless steel backguard
- One Year limited parts & labor (USA & Canada)

Optional Features:

- Stainless steel sides (spreader end unit only)
- Stainless steel main back (spreader cabinet only)
- Swivel casters complete with front brakes, set of 4
- 6" (152mm) adjustable stainless steel legs
- Double deck high shelf

Specifications:

Spreader cabinets provide additional work space between ranges or at the end of a battery. Standard widths are 12" (303mm), 18" (457mm), 24" (610mm) and 36" (914mm). Stainless steel front and black power coat epoxy sides. Cabinets provide convenient, concealed and sanitary storage for pots and pans.



MODEL	Width	Height	Depth	Shipping	
				Wt LB/Kg	Cu ft
36ESC12	12" (303mm)	36" (914mm)	36" (914mm)	63/29	2
36ESC18	18" (457mm)	36" (914mm)	36" (914mm)	70/31	3
36ESC24	24" (610mm)	36" (914mm)	36" (914mm)	77/34	5
36ESC36	36" (914mm)	36" (914mm)	36" (914mm)	80/35	9

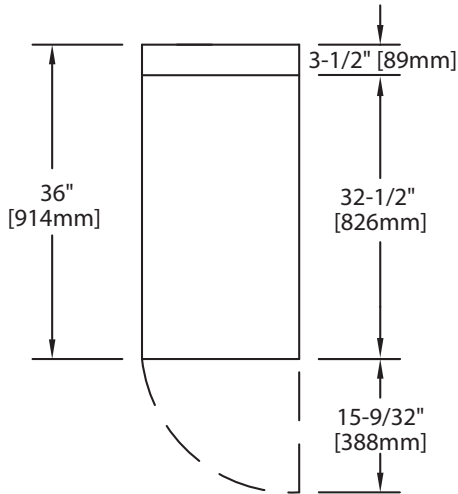

Garland products are not approved or authorized for home or residential use, but are intended for commercial applications only. Garland will not provide service, warranty, maintenance or support of any kind other than in commercial applications.

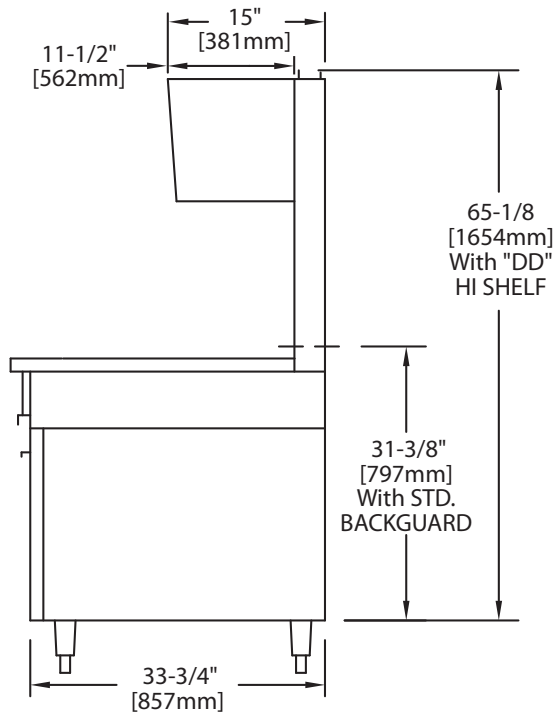
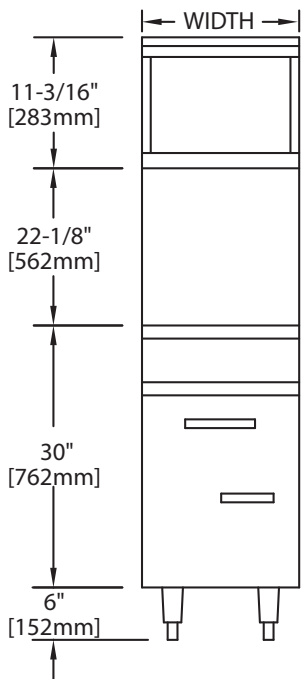

Form# 36ESC12/18/24/36 (04/01/11)