



800 Watt

Fondant Warmer

Item: EFW800

Quantity: _____

Project: _____

Approval: _____

Date: _____

800 Watt Fondant Warmer

Models:

EFW800



Standard Features:

- Full size, 12" x 20" (305mm x 508mm), 4" (102mm) deep pan
- Simple ON-OFF Control
- All Stainless Steel Finish
- Fully insulated tank
- 72" (1829mm) power cord with NEMA 5-15P plug
- 120V Standard
- Two heating elements, with independent temperature limits.
- A ready indicator, indicating normal set point operation water temperature of 122°F ± 3°F (50°C ± 1.5°C) and a fondant temperature of 115°F (45°C)
- Fast Heat set point to achieve a temperature of 150°F ± 5°F (65°C ± 3°C) when first turned on for rapid warm up
- Low water alarm, with flashing indicator and an automatic 50% reduction in heat
- Sensor failure or over temperature warning with illuminated indicator and the commencement of a timed heating cycle approximating normal operation
- Limited 1-year factory warranty, (please call 800.427.6668 for warranty service instructions and details)

Specifications:

The Garland EFW800 is a full size, wet use-only Counter Fondant warmer with all stainless steel finish and fully insulated tank. The 800 watt unit comes standard with a NEMA 5-15P cord and plug, which enables use in any location where there is an appropriate 120V electrical outlet. A combination of fast heat and normal operation set points enables a full load of fondant to go from room temperature to operating temperature in 30 minutes and maintain an average operating temperature of 115°F (46°C). The tank accepts full size pans up to 4" deep. Over heat and low water alarms come standard.



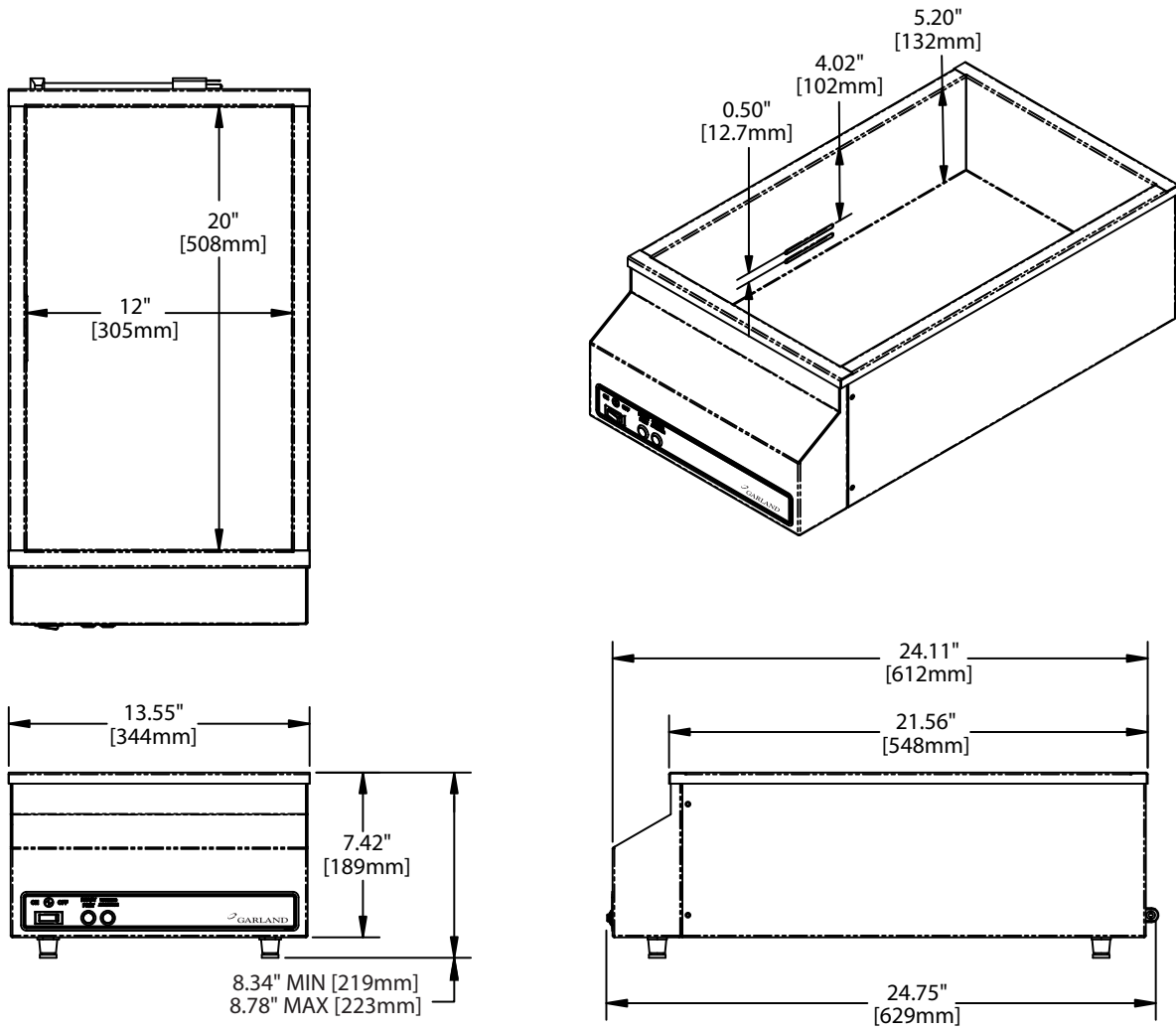

Voltage	Phase	kW	Nominal Amperes	Connection Type
120	1	.80	6.7	6' cord w/NEMA 5-15P plug

Clearances				Shipping Weight
Installation		Entry		
Sides	Rear	Crated	Uncrated	
0"	0"	15.8" (401mm)	13.55" (344mm)	29 lb (13.2kg)

Form# EFW800 (03/30/11)