



Induction Baby Hob Built In

Item: GIU 2.5 BI (BH/IN 2500)

Quantity: _____

Project: _____

Approval: _____

Date: _____

Induction Baby Hob Built In

Models:

GIU-2.5 BI (BH/IN 2500)

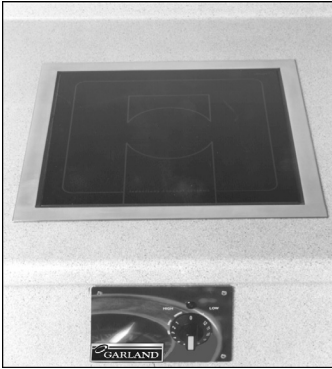

Installation Notes:

The unit is designed to be installed into a counter. An integral cooling fan keeps the electronics cool. Garland offers an optional air intake kit, recommended for all enclosed installations. The unit takes cooling air in from the bottom, and discharges from both sides. The optional air intake kit connects directly to the unit. A minimum of 30 sq. inch (19.34 sq. cm) opening for the exhaust must be allowed for proper operation in the design of the cabinet.

Standard Features:

- Drop-in, flush mounted design with stainless steel body below counter and high impact ceramic glass top
- Remote control and indicator light mounted on a control panel plate with a 3 foot (914mm) cable
- Integral cooling fan keeps electronics cool and provisions must be made to allow for air intake and exhaust when mounted in a counter
- 6' (1829mm) cord and plug supplied (60 cycle units only)
- "Flat Design", compact high performance electronics
- Thermostatically controlled overheat sensor shuts the unit off preventing damage from pans cooking dry
- Instant energy transmission to the pan
- Induction technology transfers heat to the pan, not to the surrounding air
- Innovated new technology for pan detection; RTCS is an internal control software development matching speed, capability and performance
 - R – Real Time
 - T – Temperature
 - C – Control
 - S – System
- Electronic output limitation continually monitors the energy transfer to the pan, helping to ensure the most efficient energy transfer possible
- 2.5 kW single-phase power only

Specifications:

Shall be a Garland Single Drop-In Induction Unit GIU-2.5BI with a total kilowatt rating of 2.5 kW. Drop-in mounts flush with counter, built with a robust stainless steel casing with ceran ceramic glass work top. Compact powerful electronic system for years of reliable service. Overheat sensors help to prevent damage if pan is run dry. Easy to operate system supplied with remote rotary mounted control. Unit to come with integral cord and plug for 208V or 240V (specify at time of order), 60 Hz, single phase.

Note: Induction cooking requires magnetic pots and pans to work effectively.



Conforms to UL-197 & NSF-4
Certified to CAN/CSA
C22.2 NO. 109 VDE EN60335-2-38

Garland Commercial Ranges Ltd.
1177 Kamato Road,
Mississauga, Ontario
L4W 1X4 CANADA

General Inquires 1-905-624-0260
USA Sales, Parts and Service 1-800-424-2411
Canadian Sales 1-888-442-7526
Canada or USA Parts/Service 1-800-427-6668



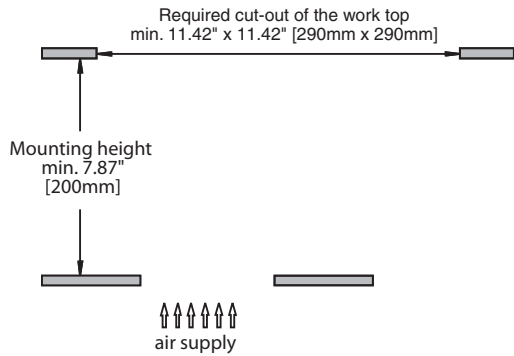
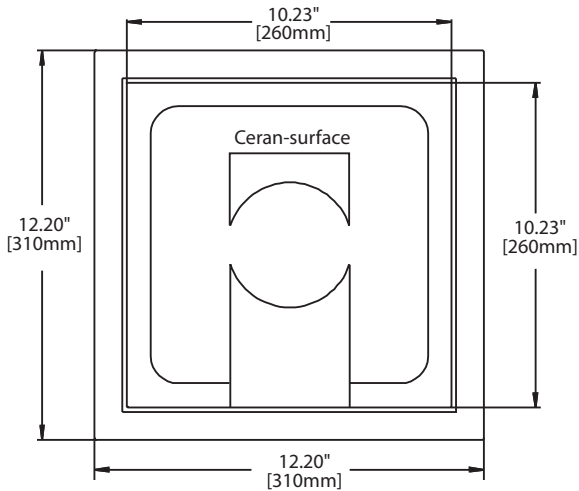
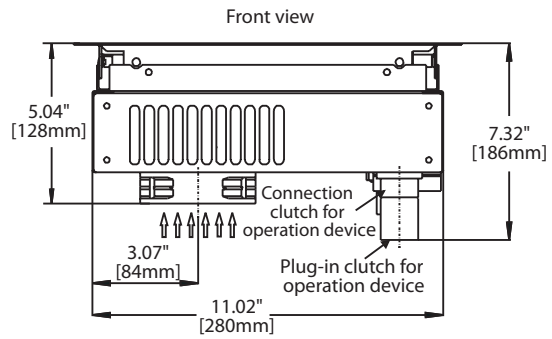
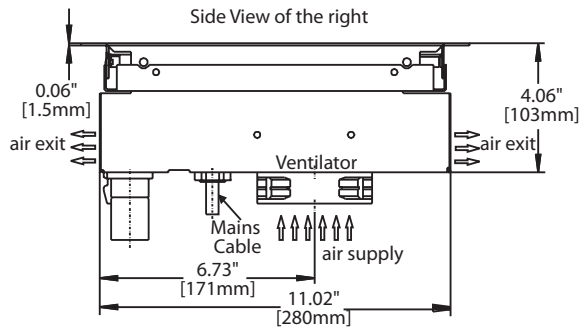

Plug Configurations:

MODEL	Electrical Characteristics	Plug
GIU-2.5 BI	208V/60Hz/1Ø 240V/60 Hz/1Ø	 NEMA 6-15P

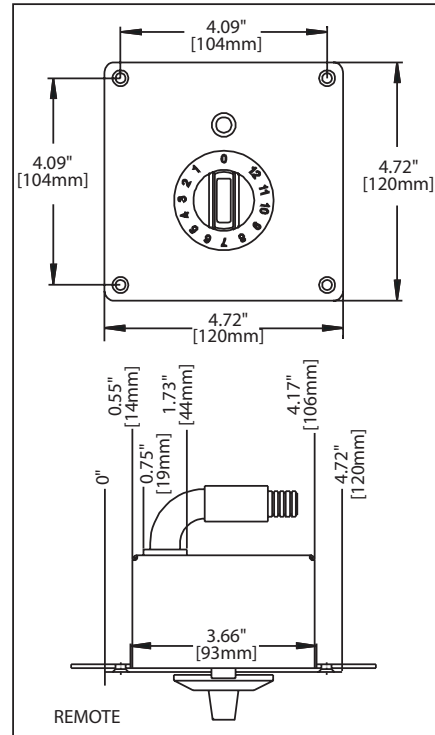

Electrical Loading:				
Model	Watts	208/60/1	208/60/3	240/60/1
GIU-2.5 BI	2500	12 amp	N/A	9 amp

Form# GIU-2.5 BI (BH/IN 2500) (07/26/11)