



## INSTALLATION AND OPERATION MANUAL

### GARLAND RTCS TECHNOLOGY TABLE TOP INDUCTION COOKERS, MODELS: BH/BA 1500, BH/BA 1800, BH/BA 2500, BH/BA 3000, BH/BA 3500, SH/BA 3500, SH/BA 5000, SH/WO 3500, SH/WO 5000 & SH/WO 8000



**FOR YOUR SAFETY:**  
DO NOT STORE OR USE GASOLINE  
OR OTHER FLAMMABLE VAPORS OR  
LIQUIDS IN THE VICINITY OF  
THIS OR ANY OTHER  
APPLIANCE

**WARNING:**  
IMPROPER INSTALLATION, ADJUSTMENT,  
ALTERATION, SERVICE OR MAINTENANCE  
CAN CAUSE PROPERTY DAMAGE, INJURY,  
OR DEATH. READ THE INSTALLATION,  
OPERATING AND MAINTENANCE  
INSTRUCTIONS THOROUGHLY  
BEFORE INSTALLING OR  
SERVICING THIS EQUIPMENT

PLEASE READ ALL SECTIONS OF THIS MANUAL  
AND RETAIN FOR FUTURE REFERENCE.

THIS PRODUCT HAS BEEN CERTIFIED AS  
COMMERCIAL COOKING EQUIPMENT AND  
MUST BE INSTALLED BY PROFESSIONAL  
PERSONNEL AS SPECIFIED.

INSTALLATION AND ELECTRICAL CONNECTION  
MUST COMPLY WITH CURRENT CODES:  
IN CANADA - THE CANADIAN ELECTRICAL  
CODE PART 1 AND / OR LOCAL CODES.  
IN USA - THE NATIONAL ELECTRICAL CODE  
ANSI / NFPA - CURRENT EDITION.

ENSURE ELECTRICAL SUPPLY CONFORMS WITH  
ELECTRICAL CHARACTERISTICS SHOWN ON  
THE RATING PLATE.

Users are cautioned that maintenance and repairs must be performed by a Garland authorized service agent using genuine Garland replacement parts. Garland will have no obligation with respect to any product that has been improperly installed, adjusted, operated or not maintained in accordance with national and local codes or installation instructions provided with the product, or any product that has its serial number defaced, obliterated or removed, or which has been modified or repaired using unauthorized parts or by unauthorized service agents. For a list of authorized service agents, please refer to the Garland web site at <http://www.garland-group.com>. The information contained herein, (including design and parts specifications), may be superseded and is subject to change without notice.

GARLAND COMMERCIAL INDUSTRIES  
185 East South Street  
Freeland, Pennsylvania 18224  
Phone: (570) 636-1000  
Fax: (570) 636-3903

GARLAND COMMERCIAL RANGES, LTD.  
1177 Kamato Road, Mississauga, Ontario L4W 1X4  
CANADA  
Phone: 905-624-0260  
Fax: 905-624-5669

Enodis UK LTD.  
Swallowfield Way, Hayes, Middlesex UB3 1DQ ENGLAND  
Telephone: 081-561-0433  
Fax: 081-848-0041



# IMPORTANT INFORMATION

The instructions in this manual are fundamentally important and must be taken into account during assembly, operation and maintenance. They must therefore be read very carefully before installation and operation by the responsible specialist staff and the operator(s). After installation keep in a prominent position for consultation and reference.

## Description Of Warning Signs



**Identifies safety information about dangers which may cause serious personal injury if equipment is not operated properly.**



**Dangerous voltage warning symbol, indicates a risk of electric shock and hazards from dangerous voltage.**

**CAUTION**

**Indicates a hazard or unsafe practice which could result in minor personal injury or property damage.**



**Electromagnetic field**



**Warning**  
**Risk of fire or electric shock**  
**Do not open**



**To reduce the risk of fire or electric shock, do not remove or open cover. No user Serviceable parts inside. Refer servicing to qualified personnel.**

Warning signs mounted directly on the cooker must be observed at all times and kept in a fully legible condition

## Health Information

### **WARNING:**

**This product contains chemicals known to the State of California to cause cancer. Installation and servicing of this product could expose you to airborne particles of glass wool/ceramic fibers. Inhalation of airborne particles of glass wool/ceramic fibers is known to the State of California to cause cancer.**



# TABLE OF CONTENTS

<b>IMPORTANT INFORMATION.....</b>	<b>3</b>	<b>OPERATION.....</b>	<b>11</b>
Description Of Warning Signs.....	3	Cooking Process .....	11
Health Information.....	3	Comfort .....	11
<b>DIMENSIONS AND SPECIFICATIONS .....</b>	<b>6</b>	Out Of Operation .....	11
<b>GENERAL INFORMATION .....</b>	<b>7</b>	Safety Concerns .....	11
Purpose Of Induction Cookers.....	7	Risk Involved By Disregarding Safety	
Description Of Products.....	7	Information .....	11
Components Supplied .....	7	Safety Conscious Work .....	11
Product Overview .....	7	Safety Information For The Operator/	
Counter Units At A Glance .....	7	Operating Personnel .....	11
Control knob.....	7	Unauthorized Reconstruction And	
<b>INSTALLATION .....</b>	<b>8</b>	Use Of Spare Parts.....	12
Siting.....	8	Improper Operating Methods.....	12
Electrical Supply .....	8	Pan Detection.....	12
Ventilation.....	8	Control Of The Heating Area .....	12
Dimensions And Clearances .....	8	<b>MAINTENANCE AND CLEANING .....</b>	<b>13</b>
Single Unit BH/BA 1500, BH/BA 1800,		Cleaning.....	13
BH/BA 2500, BH/BA 3000 And		Maintenance .....	13
BH/BA 3500 .....	8	<b>TROUBLESHOOTING .....</b>	<b>14</b>
Single Unit SH/BA 3500 and SH/BA 5000...	9	Error Messages .....	14
SH/WO 3500, SH/WO 5000 and		Malfunction Without Error Code.....	15
SH/WO 8000 .....	9	<b>WASTE DISPOSAL PROCEDURES .....</b>	<b>17</b>
Cooker Setup.....	10		
Operating Test.....	10		

# DIMENSIONS AND SPECIFICATIONS

OPERATION CONTROL	
Lamp Operation	24V DC/max. 40mA (green)
Power Regulation	Potentiometer 10KOHM

OPERATING CONDITIONS		
Maximum Tolerance of Supply Voltage	+6/-10%	
Supply Frequency	50/60 Hz	
Protection Class	IP XO	
Minimal Diameter Of The Pan (BH/IN and SH/IN)	4 3/4" (120mm)	
Maximum Ambient Temperature	Storage	-4° to 158°F (-20° to 70°C)
	Function	41° to 104°F (5° to 40°C)
Maximum Relative Humidity Of Air	Storage	10%-90%
	Function	30%-90%

ELECTRICAL SPECIFICATIONS			
MODEL	VOLTAGE	Total KW	Weight
BH/BA 1500	120V	1.5 kW	19.8 lb (9kg)
BH/BA 1800	120V	1.8kW	19.8 lb (9kg)
BH/BA 2500	208/230/240	2.5kW	19.8 lb (9kg)
BH/BA 3000	208/230/240	3.0kW	19.8 lb (9kg)
BH/BA 3500	208/230/240	3.5kW	19.8 lb (9kg)
SH/BA 3500	208/230/440	3.5kW	24.2 lb (11kg)
SH/BA 5000	208/400/440	5.0kW	24.2 lb (11kg)
SH/WO 3500	208/400/440	3.5kW	28.6 lb (13kg)
SH/WO 5000	208/400/440	5.0kw	28.6 lb (13kg)
SH/WO 8000	400	8.0kW	28.6 lb (13kg)

DIMENSIONS		
Model	Glass Ceramic	Width x Depth x Height
BH/IN	10.24" x 10.24" (260mm x 260mm)	16.60" x 14.96" x 4.13" (320 x 380 x 105 mm)
SH/IN	12.60" X 12.60" (320mm x 320 mm)	14.96" x 17.32" x 5.43" (380 x 440 x 138mm)
SH/WO/IN	ø 11.81" (300mm)	14.96" x 17.32" x 198" (380 x 440 x 198)

# GENERAL INFORMATION

## Purpose Of Induction Cookers

The induction cookers are counter top cookers suitable for in the kitchen or for the preparation of meals on the table. The cookers can be used for cooking, keeping warm, flambéing, roasting, etc. of food. Only recommended types and sizes of pans should be used. Do not use NO NAME pan material but only pans appropriate for induction cooking!

## Description Of Products

### Components Supplied

The unit is delivered complete and in working order.

### Product Overview

Garland supplies several basic types of units with different performances and measurements. Built with a robust method of construction, they are compact and powerful with a revolutionary technology in a complete case of CrNi-steel. Equipped with continuous control, allowing for efficient cooking and have the following features:

- Simple operation with rotary switch with integrated mains switch.
- Compact powerful electronics enable flat construction and safe operation.
- A maximum of safety thanks to multiple functions of protection and checking.
- Short cooking time.
- Electronic checking of the energy supply
- Compact measurement – light weight.
- Fulfills the latest standards: VDE EN 50366, VDE EN 60335-1;-2/36; CE-conforming; UL 197, CAN/CSA/C 22.2 No. 109.

## Counter Units At A Glance

Before carrying out function checks, the operator must know how to operate the cooker.

## Control knob

The number that points to the operation indicator marks the actual position of the control knob.

### OFF-POSITION

0 Points to the operation indicator

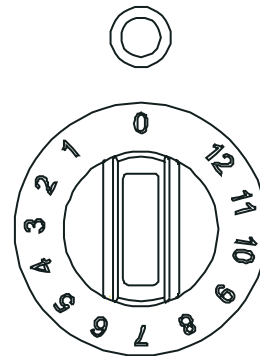

### ON-POSITION

Any position when a number other than 0 points to the operation indicator

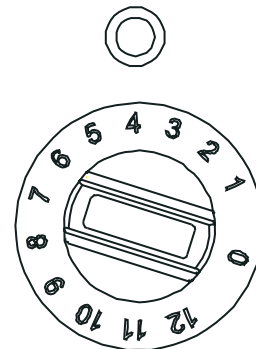

# INSTALLATION

## Siting

The cooker has to be set up on a even place like a table. The air inlet and air outlet must not be obstructed, the area must be able to withstand a loading of 88 lbs (40 kg). The control knob to operate the cooker must be easily accessible.

## Electrical Supply

Please observe the following rules:

1. Check and ensure that the supply voltage and the line current matches the specifications given on the rating plate.
2. The electrical connections must satisfy national and local electrical codes.
3. This induction appliance is equipped with mains cable and plug which can be connected to the socket. The connector must be easily accessible to disconnect the unit from the electrical supply.
4. When faulty-current circuit breakers are used, they must be rated for a breaking current of 30mA or more.

## Ventilation

Please read carefully and comply with the following rules.

1. This induction unit is equipped with an air cooling system. Be sure that the air supply and air exhaust are not blocked (wall, fabric etc.).
2. This induction unit is equipped with an additional grease filter. Ensure that the induction unit does not take in hot ambient air (concerns units standing side by side, or one behind the other, or standing near a frying pan or an oven).
3. The induction unit must not be placed next to an oven or another heat producing unit.
4. The air intake temperature must be under 104°F (40°C)
5. The operating staff has to make sure that installation, support and inspection is done by qualified personnel.

## Dimensions And Clearances

Single Unit BH/BA 1500, BH/BA 1800,  
BH/BA 2500, BH/BA 3000 And BH/BA 3500

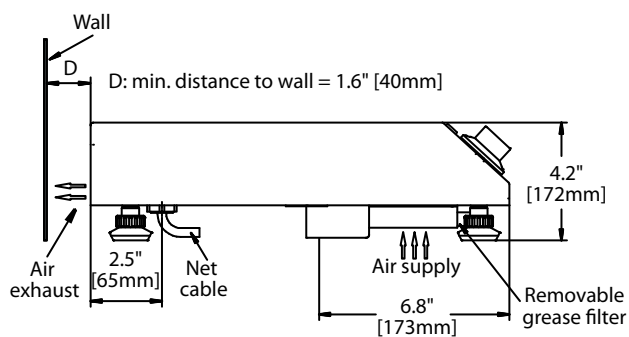
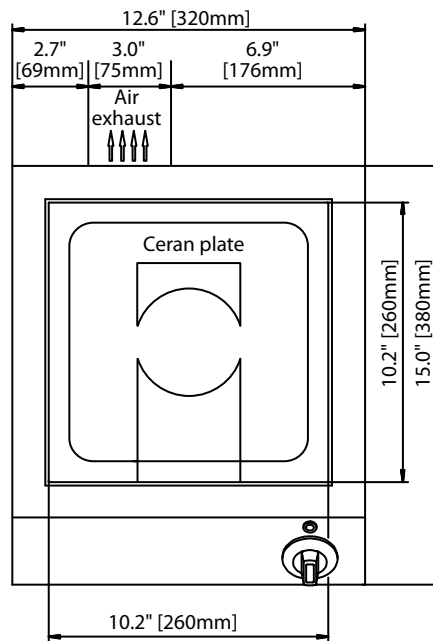



# INSTALLATION continued

## Single Unit SH/BA 3500 and SH/BA 5000

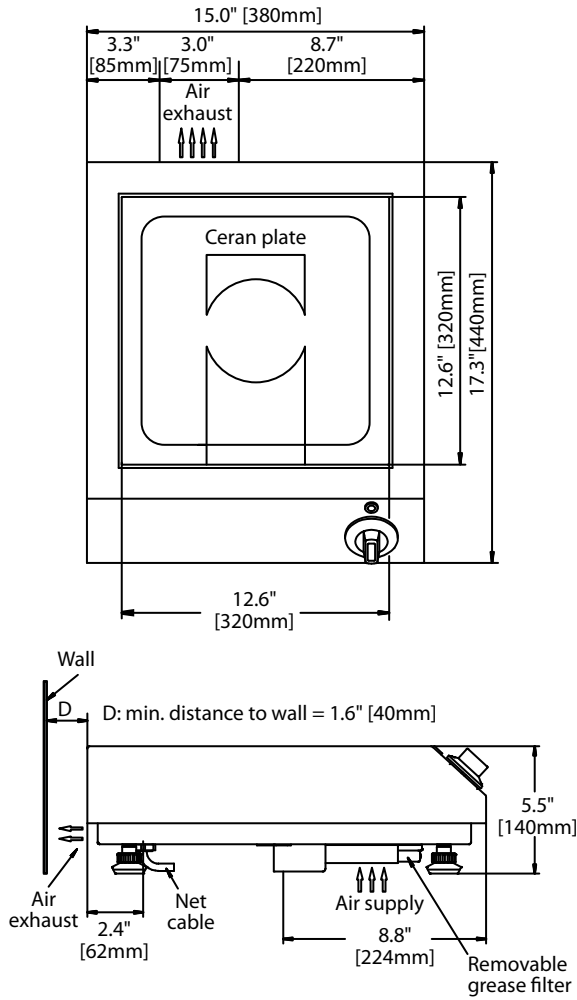

## SH/WO 3500, SH/WO 5000 and SH/WO 8000

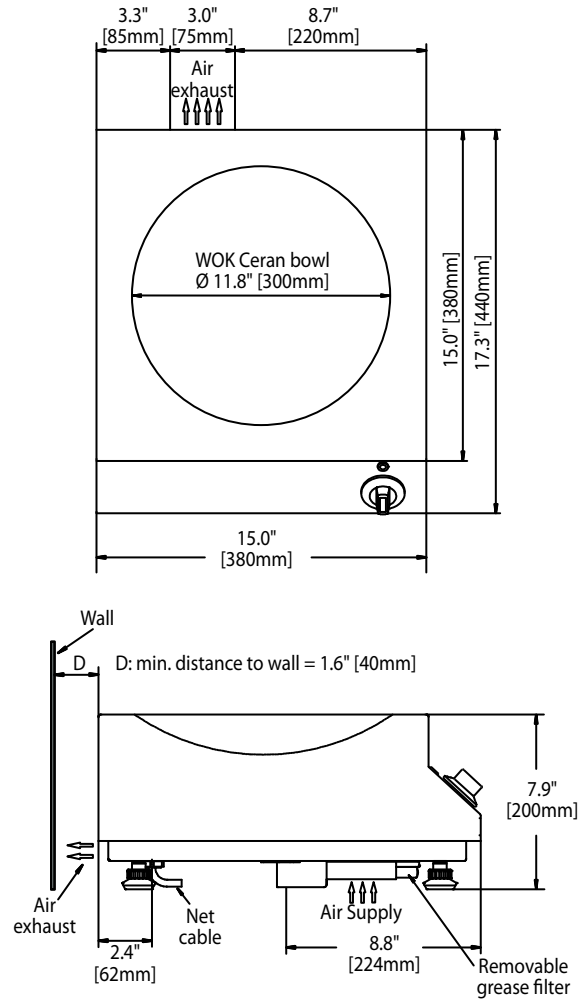

# INSTALLATION continued

## Cooker Setup

The cookers are equipped with a mains cable. They have to be connected to a wall socket.

The installation for the electricity must be fitted by approved installation contractors in accordance with specific national and local codes. The installation contractors are responsible for the correct layout and installation in conformity with all safety regulations. The warning signs and specification plates put up to the appliances must strictly be followed.

The cooker must always be set up on a clean and even surface (table, base, etc.) at its designated site. The cooker stands on non-slip rubber pads and is not permanently installed. It must be set up in a way that it cannot fall down or move in a uneven position. The conditions outlined in the Sitings section must be followed.

Turn the control knob in the OFF-position before connecting the cooker to the voltage supply.

Remove all objects from the glass ceramic cooking zone, verify if this area is neither cracked nor broken. Do not use it when the glass ceramic cooking zone is cracked or broken, immediately switch off and disconnect the cooker from the outlet.

## Operating Test

### CAUTION

**The glass ceramic cooking zone is warmed up from the heat of the pan. To avoid injuries (burning) do not touch this area.**

Use a pan suitable for induction cooking, having a bottom diameter of at least 4.72" (120mm).

- 1 Put some water in the pan and place it in the center of the heating area.

2. Turn the control knob ON (in a position between 1 and 12 (9)). The indicator will light will illuminate (green) and the water will be heated.
3. Take the pan away from the heating area, the indicator light will flash.
4. Place the pan back on the heating area, the indicator will light and the heating process will continue.
5. Turn the control knob in the OFF-position, the heating process will stop, indicator light turns off.

NOTE: The shining operation indicator light means that energy is being transferred to the pan. If the operation indicator light remains off, check the following:

1. Is the cooker connected to the outlet?
2. Is the control knob in ON position?
3. Did you use a suitable pan (bottom diameter at least 4.72" (120mm) pan made of suitable material)?
4. Is the pan placed in the center of the heating area?

To verify, if the pan is suitable, use a permanent magnet and find out if it sticks on the bottom of the pan. If not, your pan is not suitable for induction cooking. Choose a pan which is recommended for induction cooking. Choose pan material suitable for induction appliances.

If in spite of all positive controls and tests, the cooker doesn't work, refer to the Fault Finding Section, or call a service representative.

# OPERATION

## Cooking Process

The induction cooker is switched on by turning the control knob (OFF ⇨ ON) and it is immediately ready for operation. The luminous operation indicator light means that energy is being transferred to the pan. The power rating is set by turning the control knob. The inductive power depends on the position of the potentiometer:

- ⇨ Position 1 > minimum power
- ⇨ Position 9 > maximum power (BH/BA only)
- ⇨ Position 12 > maximum power

Due to the following characteristics, the operator must be more attentive when using the induction cooker than it would be required with other appliances:

The heat storage capacity of this system is very low. If the heating level is changed by turning the control knob, the food is immediately exposed to a different temperature. **Do not put empty pans on the cooking zone**, first put grease or liquid into the pan and start the cooking process afterwards. Empty pans and pots heat up very quickly. Adjust the heating level carefully to the required cooking mode. Set and adjust the power by turning the control knob.

The pan should always remain in the center of the heating area, otherwise, the bottom of the pan is heated up unequally and the food inside the pan may burn. When heating up oil or grease, constantly check the pan to prevent oil and grease from overheating and burning.

When using a GN-pan for heating by induction just use the cooking positions of 1 or 2.

## Comfort

The cooker transmits energy only when a pan is placed on the heating area, independently of the position of the control knob. If you take the pan away from the heating area, power transfer to the pan stops immediately. If the pan is put back on the heating area, the selected power will be transferred to the pan again.

After switching the cooker to the off position the cooking process will stop. Except for the pan, no heat is stored.

## Out Of Operation

If the cooker is not in use make sure that the control knob is in the "OFF" position. If you don't use the cooker for a long period (several days), unplug the unit. Make sure that no liquid can enter into the cooker, do not clean the cooker with a jet of water.

## Safety Concerns

### Risk Involved By Disregarding Safety Information

Danger for persons, the environment and the cooker can result from disregarding safety information. Certain risks may be associated with disregarding precautions, including:

- Danger to persons through electrical causes.
- Danger to persons through overheated pans.
- Danger to persons through an overheated cooking platform (ceran plate).

### Safety Conscious Work

The safety information pointed out in these instructions, existing national regulation for the prevention of accidents as well as any internal working, operating and safety regulations stipulated by the operator must be observed at all times.

### Safety Information For The Operator/Operating Personnel

The following safety precautions should be followed at all times:

- The heating area is warmed up from the heat of the pan. To avoid injuries (burning) do not touch the heating area.
- To avoid overheating of pans due to the evaporation of the content, don't leave pans unattended.
- Switch the control knob off if you take the pan away for a while. This will avoid the heating process to continue automatically when a pan is placed back on the heating area. So, if any person starts to use the cooker, he/she will have to start the heating process by turning the control knob in the ON-position.

## OPERATION continued

- Do not insert any piece of paper, cardboard, cloth, etc. between the pan and the heating area, as this might initiate a fire.
- Since metallic objects are heated up very quickly when placed on the heating area, do not place any other objects (closed cans, aluminium foil, cutlery, jewelry, watches etc.) on the induction cooker.
- Persons with a pacemaker should consult their doctor whether they are safe near an induction cooker.
- Aluminium foil and plastic vessels must not be placed on the hot surface.
- The surface must not be used for storage.
- Do not place credit cards, phone cards, cassette tapes, or other objects sensitive to magnetism on the Ceran glass.
- The induction cooker has an internal air-cooling system. Do not obstruct the air inlet- and air outlet-slots with objects (cloth). This would cause overheating and therefore the cooker would switch off.
- Avoid liquid entering into the cooker. Do not let water or food overflow the pan. Do not clean the cooker with a jet of water.
- If the heating area (Ceran glass) is cracked or broken, the induction cooker must be switched off and disconnected from the electric connection. Don't touch any parts inside the cooker.
- Do not use pans with an uneven bottom.
- If the supply cord is damaged, it must be replaced by the manufacturer, the service agent or a similarly qualified person in order to avoid a hazard.

### Unauthorized Reconstruction And Use Of Spare Parts

Reconstruction of the cooker or changes to the cooker are not allowed. Contact the manufacturer if you intend to make any changes on the cooker. To guarantee safety, use only genuine spare parts and accessories authorized by the manufacturer. The use of other components will void all warranty.

### Improper Operating Methods

The operating reliability of the cookers can only be guaranteed by careful use.

### Pan Detection

Pans having a diameter less than 4.72" (120 mm) are not detected. During pan detection, the indicator operation flashes. No power is transferred and the indicator lamp flashes if no pan or an unsuitable pan is detected.

### Control Of The Heating Area

The heating area is controlled by a temperature sensor. Overheated pans (hot oil, empty pans) can be detected. Energy transfer will be stopped. The induction unit must be re-started after it has cooled down.

# MAINTENANCE AND CLEANING

**NOTE:** ensure no liquid can enter the induction unit, do not clean the cooker with a jet of water.

## Cleaning

### Slight soiling, no burned residues

Wipe with a moist cloth (scotch), without a cleaning agent.

### Sticky soiling

Remove with a scraper, then wipe the heating area with a moist cloth.

### Lime deposits, caused by water which has boiled over

These spots can be removed with vinegar or a special cleaning agent.

### Sugar, sugar containing food, plastic, aluminum foil

1. Immediately scrape off the sugar, plastic or aluminum foil residues thoroughly from the hot cooking area, e.g. with a razor blade.
2. After removal of the residues, clean unit with a cleaning agent.
3. If the heating area soiled with residues of sugar, plastic or aluminum foil cools down without prior cleaning, the ceramic surface might become deformed by pinhead-sized pits.

## Ceran glass

1. The cleaning of the Ceran glass is identical to other similar surfaces like glass. Do not use corrosive or abrasive cleaning agents, such as grill- and oven-sprays, stain- and rust-removers, scouring powder and rough sponges.
2. Before being cleaned, the Ceran glass must have cooled down.

## Maintenance

Other maintenance and servicing work other than cleaning as described here, must be done by authorized service personnel.

A good maintenance of the induction cooker requires a regular cleaning, care and servicing. The operator has to ensure, that all components relevant for safety are in perfect working order at all times

The cooker should be examined at least once a year by an authorized technician.

<p><b>CAUTION</b>      <b>Do not open the cooker, dangerous electric voltage inside..</b></p>
---

The cookers may only be opened by authorized personnel.

# TROUBLESHOOTING

The cookers may only be opened by authorized service personnel.

NOTE: Stop any actions if the heating area (Ceran glass) is cracked or broken. The induction cooker must be switched off and disconnected from the electric supply. Don't touch any parts inside the cooker.

## CAUTION

**Do not open the cooker, dangerous electric voltage inside..**

## Error Messages

Number of Flashing Signals (Code)	Possible Cause	Action To Take By Operator Or Operating Personnel
E03 -...-...	Overheated heat sink	Let unit cool down Check air filter and air flow
	Air-cooling system obstructed	Verify that air inlet and air outlet are not obstructed with objects Clean air filter
E04 -...-...	Overheated cooking zone	Let unit cool down Check air filter and air flow
E06 -.....-.....	Overheated electronic	Let unit cool down Check air filter and air flow
	Ambient temperature too high (the cooling system is not able to keep the cooker in normal operating conditions <sup>1</sup> )	Verify that no hot air is sucked in by the fan. Reduce the ambient temperature. The air inlet temperature must be lower than 104°F/40°C
E07 -.....-.....	Empty cooking sensing element activated	Reset empty cooking protection by switching the unit off
E08 -.....-.....	Ambient temperature beyond operating range	Make sure that the operating conditions (especially the ambient temperature) are kept
	Error on sensing element	Contact service agent

Order of error message: The indicator lamp lights up for an interval of 0.6 sec. The number of the following short flashes has to be counted and informs about the kind of error corresponding to the above mentioned code system.

<sup>1</sup> The cooling-system (fan) starts to operate when the ambient temperature in the control area exceeds 131°F/55°C. At heat temperatures higher than 158°F /70°C the controller automatically reduces the power to keep the unit in normal operating conditions. The cooker runs in a non continuous mode. This mode can be heard.

# TROUBLESHOOTING continued

## Malfunction Without Error Code

Fault	Possible Cause	Action To Take By Operator Or Operating Personnel
No heating Operation indicator light is OFF (dark)	No mains supply	Check the electrical supply (cable plugged onto the wall socket) Check preliminary fuses
	Control knob is in OFF-position	Turn control knob ON
	Cooker is defective	Ask your supplier for repair service Unplug the cooker from the mains supply
No heating Operation indicator light is flashing (If an error code is flashing see section "Malfunction with error code")	Pan is too small (bottom diameter less than 4.72" (120mm),	Use a suitable pan
	Pan is not placed in the center of the heating area (the cooker cannot detect the pan)	Move the pan to the center of the heating area
	Unsuitable pan	Choose a pan recommended for induction cooking <sup>1</sup>
	Cooker defective	Ask your supplier for repair service, unplug the cooker from the mains supply
Poor heating Operation indicator light is ON (shining)	Used pan is not appropriate	Use a pan recommended for induction cooking and compare the result with "your" pan
	Air-cooling system obstructed	Verify that air inlet and air outlet are not obstructed with objects
	Ambient temperature is too high (the cooling system is not able to keep the cooker in normal operating conditions <sup>2</sup> )	Verify that no hot air is sucked in by the fan. Reduce the ambient temperature. The air inlet temperature must be lower than 104°F /40°C.
	One phase is missing (only units with three phase supply)	Check preliminary fuses
	Cooker defective	Ask your supplier for repair service, unplug the cooker from the electrical supply
No reaction to control knob positions	Control knob defective	Ask your supplier for repair serviced, unplug the cooker from the mains supply
Heating cycle switches off and on Within minutes, fan is active	Air inlet or outlet obstructed	Remove objects from air inlet and air outlet slots, clean the slots
	Grease filter is dirty	Clean grease filter
Heating cycle switches off and on Within minutes, fan is never active	Fan defective Fan control defective	Ask your supplier for repair service

<sup>1</sup> To verify, if the pan is suitable, use a permanent magnet and find out if it sticks on the bottom of the pan. If not, your pan is not suitable for induction cooking. Choose a pan which is recommended for induction cooking. Choose pan material suitable for induction appliances.

<sup>2</sup> The cooling-system (fan) starts to operate when the ambient temperature in the control area exceeds 131°F/55°C. At heat temperatures higher than 158°F /70°C the controller automatically reduces the power to keep the unit in normal operating conditions. The cooker runs in a non continuous mode. This mode can be heard.

## TROUBLESHOOTING continued

Fault	Possible Cause	Action To Take By Operator Or Operating Personnel
After a long permanent operating time, the heating switches off and on within minutes	Coil overheated, cooking area too hot Empty pan Pan with overheated oil	Switch cooker off, remove pan and wait until the cooking area has cooled off
Small metallic objects (e.g. spoon) are heated up on the cooking area	Pan detection tuned incorrectly	Ask your supplier for repair service

- <sup>1</sup> To verify, if the pan is suitable, use a permanent magnet and find out if it sticks on the bottom of the pan. If not, your pan is not suitable for induction cooking. Choose a pan which is recommended for induction cooking. Choose pan material suitable for induction appliances.
- <sup>2</sup> The cooling-system (fan) starts to operate when the ambient temperature in the control area exceeds 131°F/55°C. At heat temperatures higher than 158°F /70°C the controller automatically reduces the power to keep the unit in normal operating conditions. The cooker runs in a non continuous mode. This mode can be heard.



# WASTE DISPOSAL PROCEDURES



The symbol  on the product or on its packaging indicates that this product may not be treated as household waste. Instead it shall be handed over to the applicable collection point for the recycling of electrical and electronic equipment. By ensuring this product is disposed of correctly, you will help prevent potential negative consequences for the environment and human health, which could otherwise be caused by inappropriate waste handling of this product. For more detailed information about recycling of this product, please contact your local city office, your household waste disposal service or the shop where you purchased the product.

When the life cycle of the cooker ends, make sure that it is disposed of it correctly.

## **Avoid abuse:**

Only persons with proper qualifications may operate the cooker.

Note: Cookers, sent for disposal, can be brought back into operation and their use should be avoided.

The cooker is built with common electrical, electromechanical and electronic parts. No batteries are used.

The operator is responsible for a proper and safe disposal of the cooker.





 **Garland**<sup>®</sup>