



Food Warmer

Item: EFW500

Quantity: _____

Project: _____

Approval: _____

Date: _____

Food Warmer

Models:

EFW500



Model EFW500

Specification:

The EFW500 is a lightweight, durable, wet-use-only Counter Food Warmer. The unit comes standard with a NEMA 5-15P cord and plug, which enables use in any location where there is an appropriate 120V electrical outlet. The 500 Watt warmer, with preset thermostat maintains a water bath temperature of 180°F - 200°F. The tank accepts 1/3-size pans up to 4" deep. Overheat protection is provided by a built-in safety high-limit thermostat. Operation is controlled by a single illuminated On/Off power switch.

Standard Features:

- Illuminated On/Off power switch
- Built-in, preset thermostat with high-limit control
- Stainless steel tank and exterior front and sides
- Power cord with NEMA 5-15P plug
- Pan capacity: one-third-size food pans up to 4" deep
- Limited 1-year factory warranty, (please call 800.427.6668 for warranty service instructions and details)



Garland Commercial Industries, LLC
185 East South Street
Freeland, PA 18224
Phone: (570) 636-1000
Fax: (570) 636-3903

Garland Commercial Ranges Ltd
1177 Kamato Road,
Mississauga, Ontario
L4W 1X4 CANADA
Phone: 905-624-0260
Fax: 905-624-5669

Enodis UK LTD
Swallowfield Way,
Hayes, Middlesex
UB3 1DQ ENGLAND
Telephone: 081-561-0433
Fax: 081-848-0041

Enodis®

Voltage	Phase	kW	Nominal Amperes	Connection Type
120	1	0.5	4.17	5' cord w/NEMA 5-15P plug

Clearances				Shipping Weight
Installation		Entry		
Sides	Rear	Crated	Uncrated	13lbs. (5.5kg)
0"	0"	9-1/2" (241mm)	7-5/8" (195mm)	

Garland products are not approved or authorized for home or residential use, but are intended for commercial applications only. Garland will not provide service, warranty, maintenance or support of any kind other than in commercial applications.

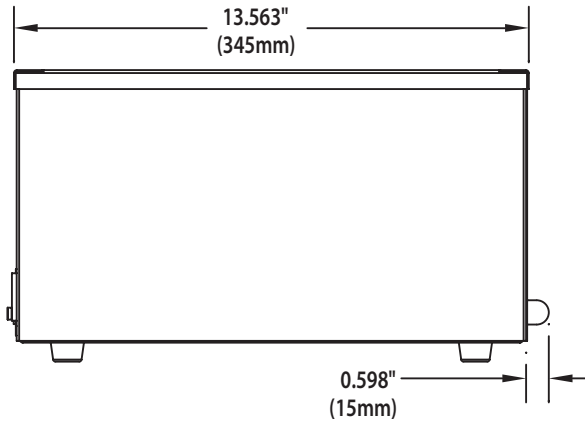
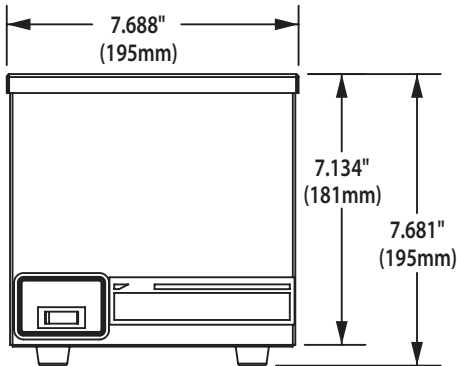
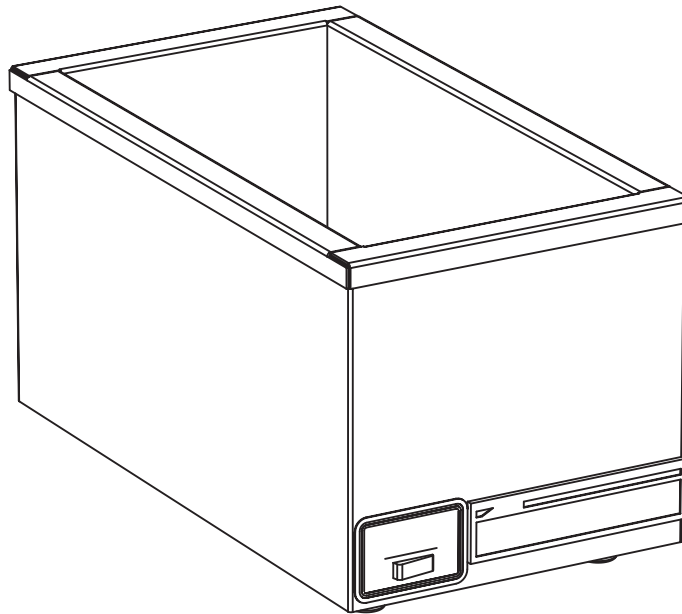
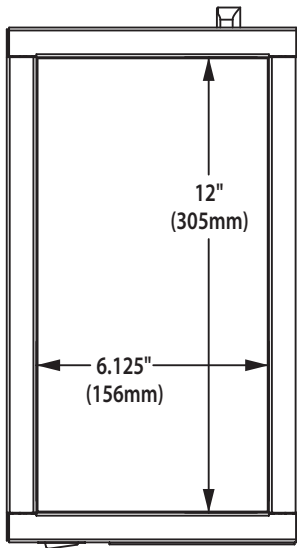

Form# EFW400 (06/07)