

GARLAND®

A **WELBILT** Company

Item #: _____

Model # UCO-E-5; UCO-E-25
Product Name: Ultimate Convection Oven,
Half Size, Electric

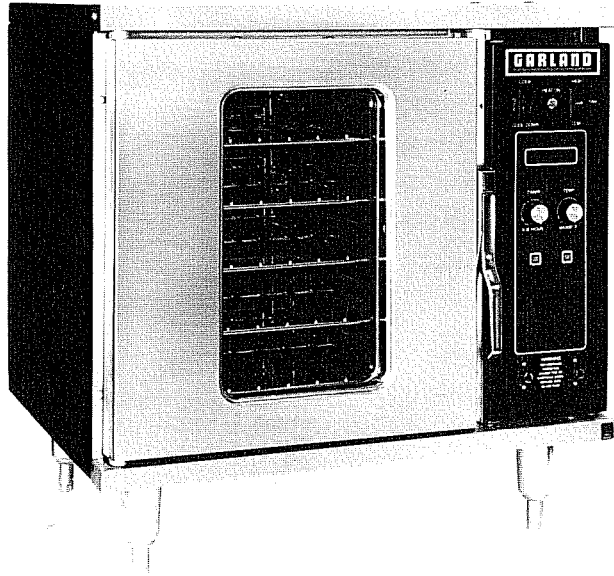

Model # UCO-E-5



SPECIFICATIONS

GENERAL

Space saving, counter model, half size convection oven designed for versatility in product application, maximum productivity, ease in operation and cleaning. Provides consistent results. Can be used in preparing baked goods such as biscuits, muffins, and cookies; convenience items including hot dogs, hamburgers and pizzas, as well as frozen entrees, roasts and vegetables.

STANDARD FEATURES

- Electronic Controls which include:
 - Cook Temperature Control with a Range of 140° F (60° C) to 500° F (260° C)
 - Cook Count Down Timer — Max 12 Hrs.
 - Timer/Temperature Digital Display
- Total 5.5 KW Loading Per Cavity
- Single speed fan of w/ 1/4 HP Motor
- Porcelain Enameled Oven Cavity
- Stainless Steel Front; Black Powder Coat Epoxy Sides, Top and Back
- Side Mounted Latched Door w/ Double Pane Thermal Window
- Five (5) Oven Racks w/Stops with 11 Position Rack Guide
- 6" (152mm) NSF Approved Chrome Plated Legs
- One Year Limited Parts and Labor Warranty
- Service Accessibility from Front

OPTIONAL FEATURES (Additional Charge):

- Two Speed Fan with 1/4 HP Motor
- Continuous Clean Oven Interior
- 28" (711mm) High — Open Base with Shelf and Rack Guides
- 28" (711mm) High — Cabinet Base with Door and Rack Guides
- Solid Stainless Steel Door
- Additional Oven Racks
- Six (6) Set Points Programmable Memory Controls
- Set of Four (4) Casters

Item #: _____

GARLAND®

A **WELBILT** Company

Model # UCO-E-5; UCO-E-25

**Product Name: Ultimate Convection Oven,
Half Size, Electric**

DIMENSIONS & SPECIFICATIONS

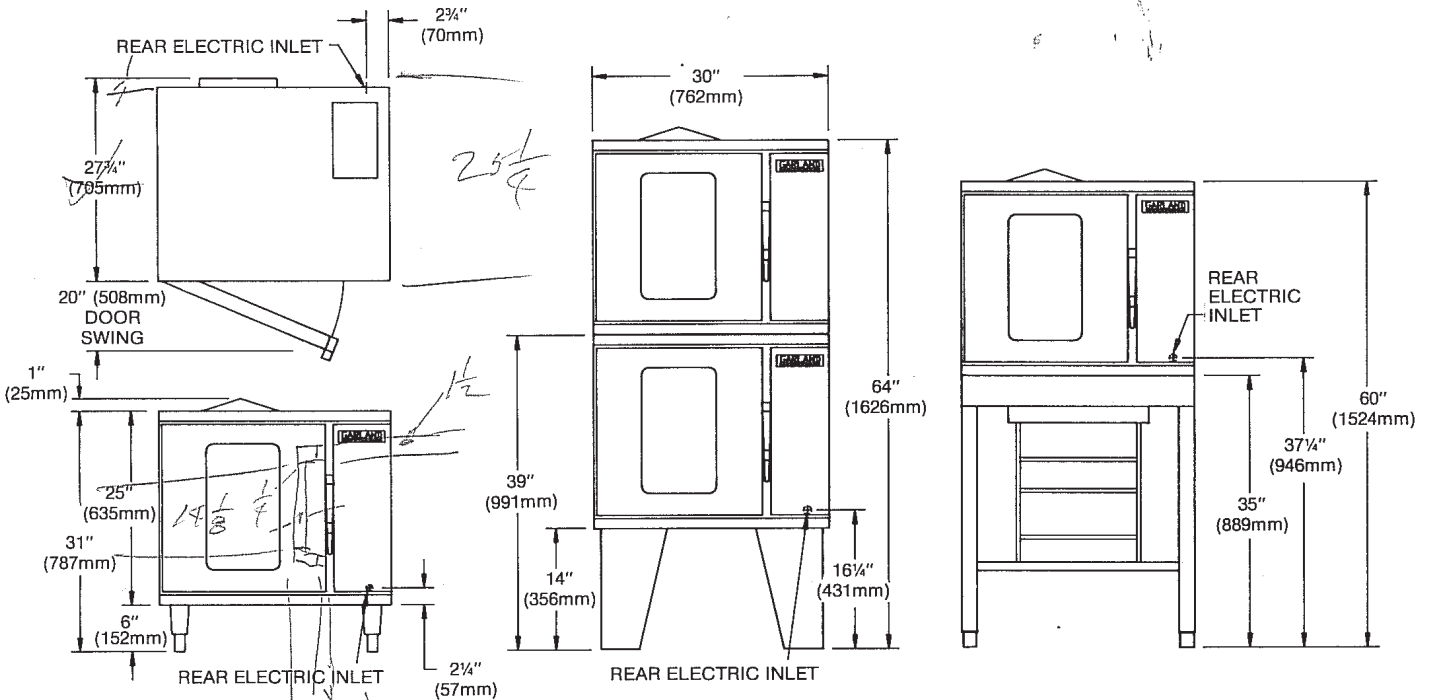

Model No.	Interior Dimensions (per deck)			Exterior Dimensions			Ship Wt.	
	W	H	D	W	H (w/legs)	D	Lbs/Kg	
UCO-E-5	16" (406mm)	20 1/4" (514mm)	21 1/8" (536mm)	30" (762mm)	28" (635mm)	26 1/8" (664mm)	350/158	
UCO-E-25	16" (406mm)	20 1/4" (514mm)	21 1/8" (536mm)	30" (762mm)	64" (1626mm)	26 1/8" (664mm)	720/326	

Model No.	Total KW			Nominal Amperes Per Line							
	Loading	208V/1PH	240V/1PH	208V/3PH	X	Y	Z	240V/3PH	X	Y	Z
UCO-E-5	5.5	26	23		13	13	21		11	11	18
UCO-E-25	11.0	53	46		25	34	34		22	29	29

Standard Electrical Specifications Include Motor Requirements

Combustible Wall Clearances
 Side and Back: 0
 Base: 0

Entry Clearance

Crated	Uncrated
32" (813mm)	30" (762mm)

Specify Electrical Characteristics When Ordering

Continuous product improvement is a Garland policy.
 Therefore, specifications and designs are subject to change without notice.