

Tuesday, April 19, 2005

## 4520244 Switch Relocation Kit Instructions

### **Model: M100XRM**

This kit is designed to relocate the illuminated power switch from the corner column of the M100XRM broiler to the valve panel of the range base. In applications where the broiler has been banked with other Master Series equipment on the left of the broiler it has been found that the power switch should be relocated to the valve panel on the range base.

### **Caution:**

- Disconnect power before proceeding.
- Turn off the main gas valve.

These modifications are to be performed by qualified service personnel according to national and local electrical and gas codes.

1. Remove broiler left corner column.
2. Remove switch and overlay from column (2146800, 4512759).
3. Remove switch wiring from corner column.
4. Install Switch Patch 4520243 to cover the switch hole on the corner column.
5. Remove grease tray, dials and existing valve panel.
6. Remove existing Inner Valve Panel.
7. Install new switch wires 2562705, 2562706, 2562707. Use drawing number 4513685 for reference.
8. Remove any protective plastic from the Switch Box 4520192 and install the new Overlay 4512759, Switch 2146800 and Cap 3011400.
9. Install the wire Bushing G01487-8 on the new Inner Valve Panel 4520242.
10. Pass the new switch wires through the Inner Valve Panel and install.



*Model M100XRM*

11. Wire the Illuminated Switch 2146800 and mount the switch box to the Inner Valve Panel.
12. Before installing the outer valve panel perform a leak test on all accessible gas connections.
13. Install the new Valve Panel 4520241.
14. Reinstall the dials and grease tray.
15. Reconnect power and test.

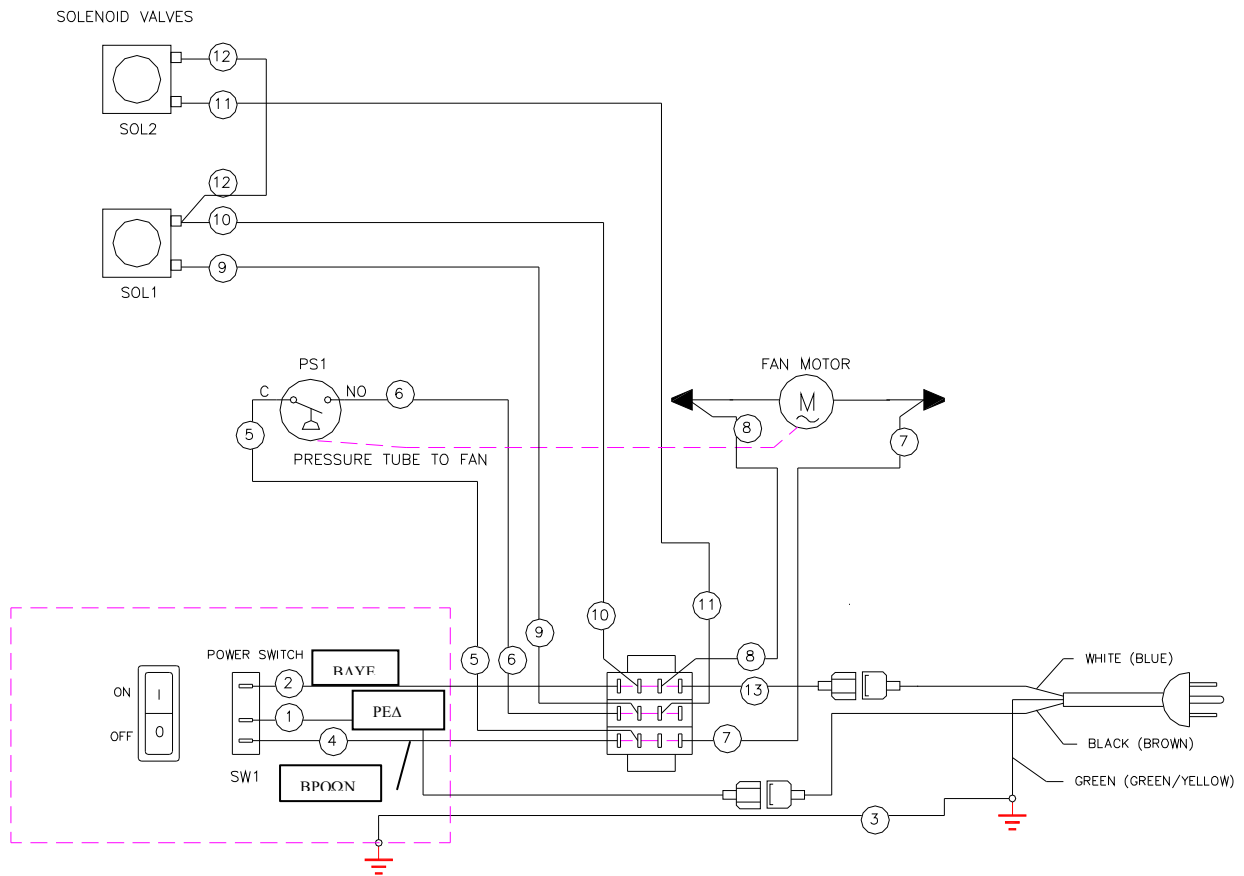

MODEL: M110XM 120VAC

**GARLAND**

GARLAND COMMERCIAL RANGES LIMITED  
MISSISSAUGA, ONTARIO, CANADA

DWG: 4513685

COMPONENTS NOT SHOWN  
 4520243 SWITCH PATCH  
 2146800 ILLUMINATED SWITCH  
 4512759 OVERLAY  
 3011400 PVC CLEAR CAP WITH BEZEL  
 2562705 WIRE - 1/4F, 1/4F 24" RED  
 2562706 WIRE - 1/4F, 1/4F 24" BLUE  
 2562707 WIRE - 1/4F, 1/4F 25" BROWN

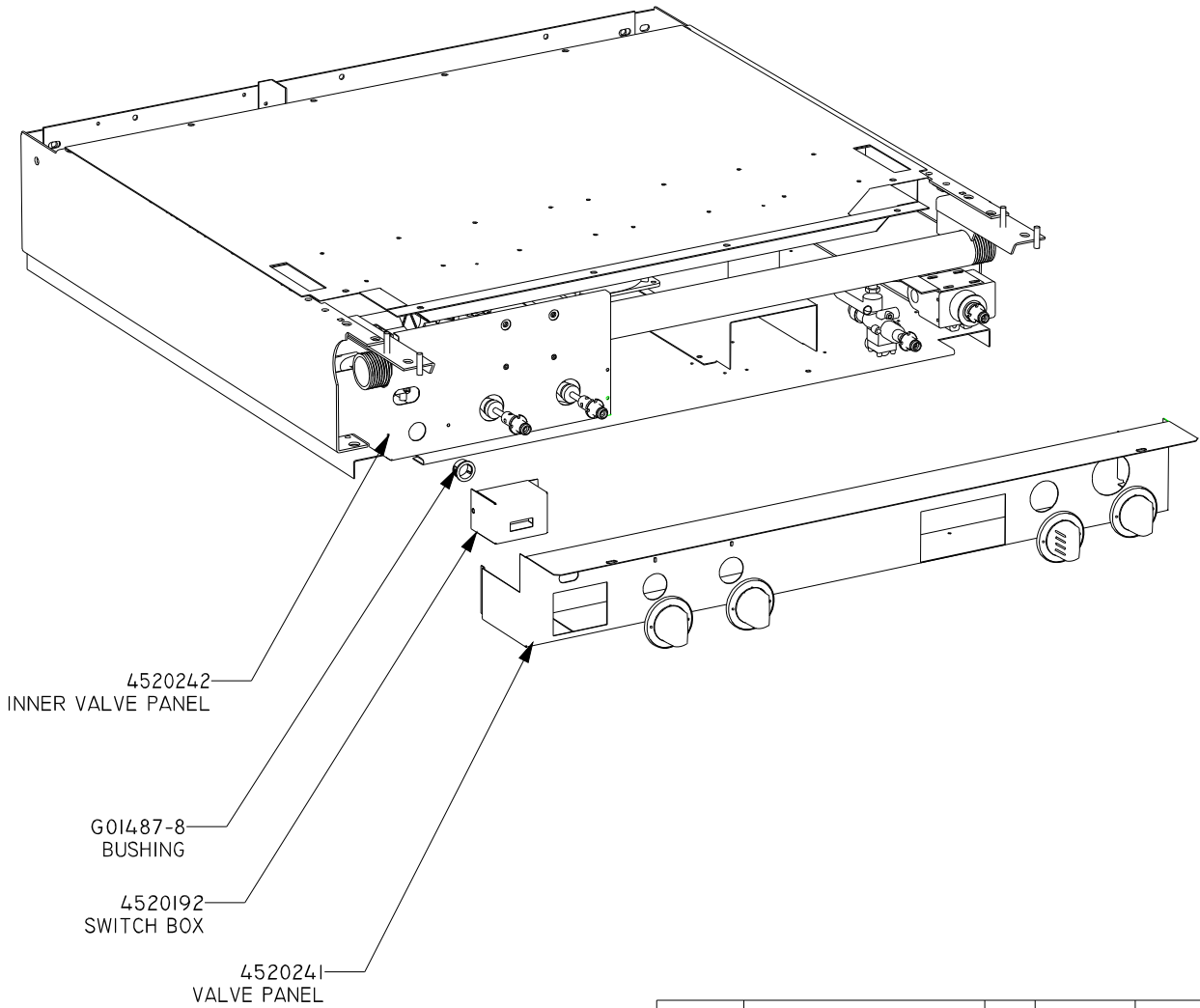

REV	DESCRIPTION	DR.	DATE	ECO
<b>REVISIONS</b>				
TOLERANCES (EXCEPT AS NOTED)			ALL DIMS. ARE IN INCHES	
±.031 ANG. ±2°				
DR: V.C.	APPR:	SCALE: 0.500	DATE: APR 19,2005	
 <b>GARLAND U.S. Range</b> <small>GARLAND COMMERCIAL RANGES LIMITED          1177 KAMATO ROAD          MISSISSAUGA, ONTARIO          L4W 1Y4</small>		<b>SWITCH RELOCATION</b>		
		4520239	M100XRM	
		SHT <u>1</u> OF <u>1</u>		