



Model G34

Specifications:

Gas medium duty range with full size oven, 30" (762 mm) wide, space saver design. Oven controlled by heavy duty FDO oven thermostat. Exterior finish to be stainless steel front and back splashwall, with black enameled sides. Top is porcelain enameled, with porcelain enameled ring grates. Complete with four (4) cast-iron star top burners, each rated at 14,000 BTU. 6" (152 mm) stainless steel legs are adjustable. Also available as a modular top without oven base.

Model G34 Standard Features:

- Stainless steel front and back splashwall, with black enameled sides
- Porcelain enameled top and ring grates are removable for easy cleaning
- Four (4) 14,000 BTU open top, cast iron star burners
- 7 ½" center porcelain flat working surface between burners
- 25,000 BTU oven burner
- Large, full size oven complete with all porcelain oven interior
- Heavy duty FDO oven thermostat
- Chrome plated 4 position removable oven rack guide with one oven rack
- 6" (152 mm) high, adjustable stainless steel legs
- One year limited warranty on parts and labor (USA and Canada only)

Optional Features:

- Swivel casters with front brakes
- Continuous clean oven interior
- Additional oven rack
- Celsius temperature dials available for oven at no charge, on request

Model G34T Modular Top Standard Features:

- Stainless steel front and back splashwall, with black enameled sides
 - Porcelain enameled top and ring grates are removable for easy cleaning
 - Four (4) 14,000 BTU open top, cast iron star burners
 - 7 ½" center porcelain flat working surface between burners
 - 1" leveling legs included for counter mounting
- Note: Counter top must be non-combustible surface



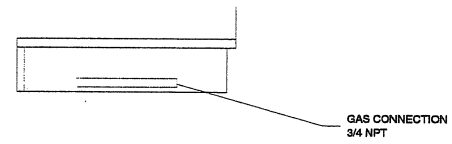
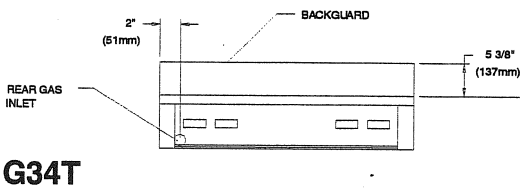
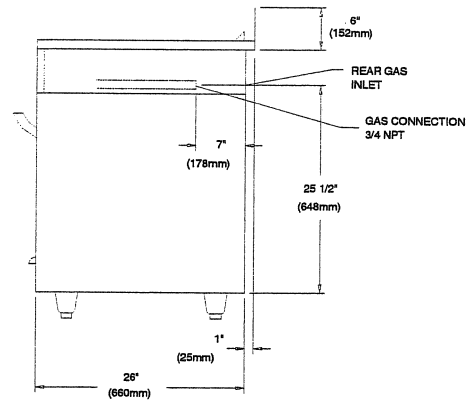
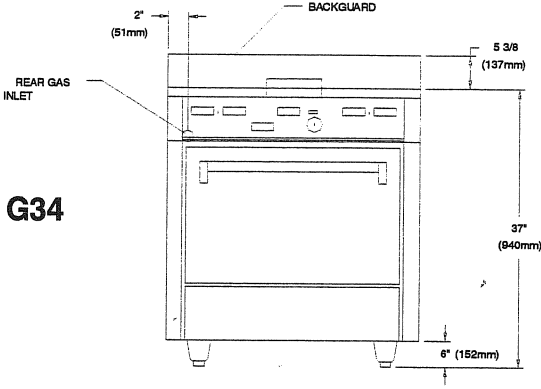
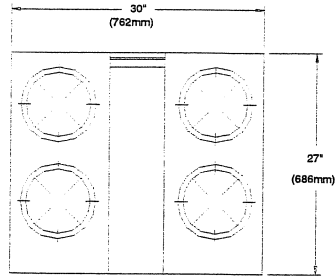

LOADING	
Burner Inputs	BTU
Open Burners	14,000
Oven Burner	25,000

Ship Weight (G34)	
Lbs.	310
kg	141

Interior Oven Dimensions	
Width	26 1/4" (667 mm)
Depth	22" (559 mm)
Height	13 1/2" (343 mm)

Installation Notes:

Equipment not installed to manufacturer's details or installed by unauthorized persons may void warranty. Clearances from combustible surfaces should be a minimum of 6" (152 mm) from back and sides. For G34T modular top unit, base of unit must be mounted on non-combustible surface.