

GARLAND®

A **WELBILT** Company

Item #: _____

Model # ECO-E-10; ECO-E-20
Product Name: Economy Convection Oven,
Full Size, Electric

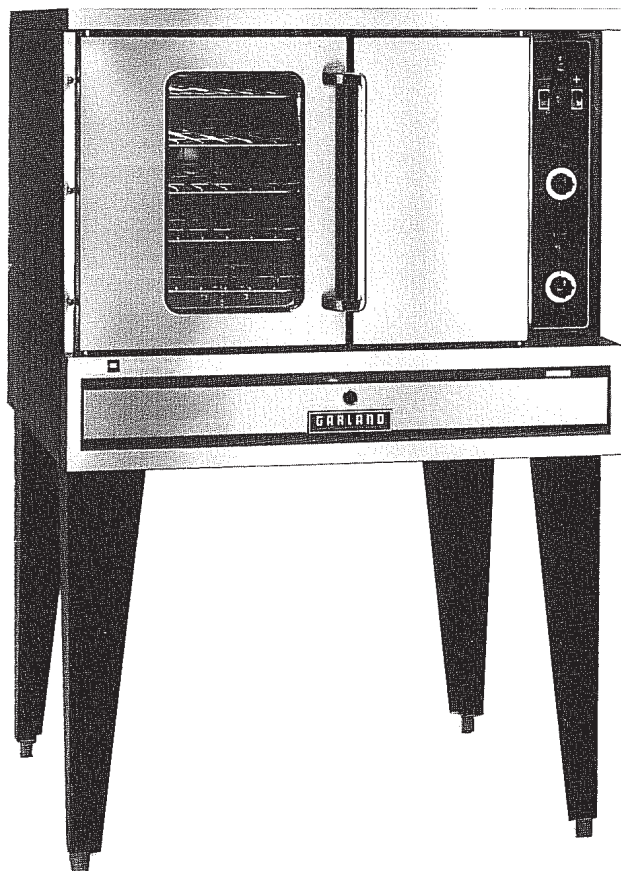

Model # ECO-E-10



Specifications

General:

Designed as a general purpose oven for baking, roasting and rethermalizing a variety of food products, faster and at lower temperatures by circulating air throughout the oven cavity.

Standard Features:

- Mechanical controls 150°F (66°C) to 500°F (260°C) temperature range
- One-hour electric timer
- Total of 11.0 kw loading per cavity
- 208 or 240 voltage
- Porcelain enameled oven cavity with coved corners
- Two speed fan with 1/2 HP motor
- Five (5) oven racks with 11 position rack guide
- Stainless steel front, black powder coat epoxy sides, top, back and legs
- 60/40 dependent door design with double pane thermal window in left door and interior lighting
- Double deck models available
- One year parts and labor limited warranty

Optional Features:

(Additional Charge)

- Windows in both doors w/ lights
- Open base with rack guides and shelf
- Extra oven racks
- Stainless steel oven interior
- Continuous clean oven interior
- Swivel casters, set of 4 with front brakes
- Perforated main back (black powder coat epoxy or stainless steel)
- Stainless steel exterior
- Stainless steel legs
- Stainless steel solid doors
- 460 voltage
- 220/380 voltage four (4) wire WYE system
- 50 cycle wiring
- Extended second year limited warranty

Control Panel Options:

(Additional Charge)

- Electronic Controls
- Programmable memory
- Cook 'n hold

Garland
Electric
Economy Convection Oven, Full-Size
Model # ECO-E-10, ECO-E-20

Item #: _____

Model # ECO-E-10; ECO-E-20
Product Name: Economy Convection Oven,
Full Size, Electric

GARLAND®

A **WELBILT** Company

SPECIFICATIONS

DIMENSIONS: $\frac{\text{inches}}{\text{mm}}$ or inches/mm

DIMENSIONS

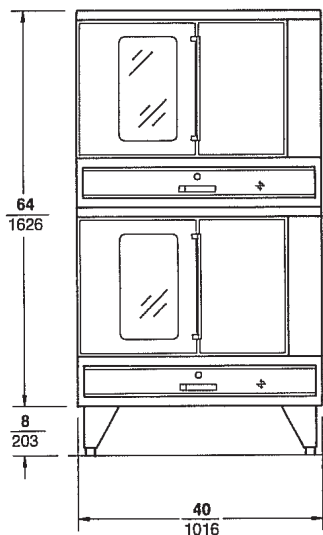

DOUBLE OVEN

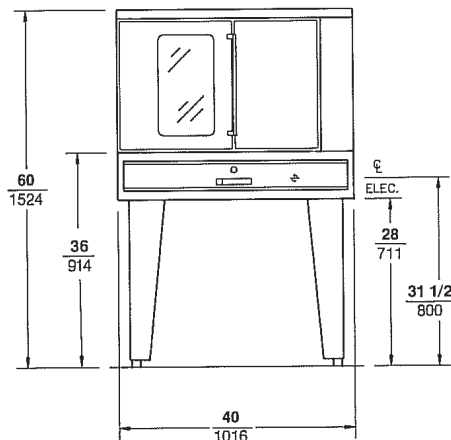
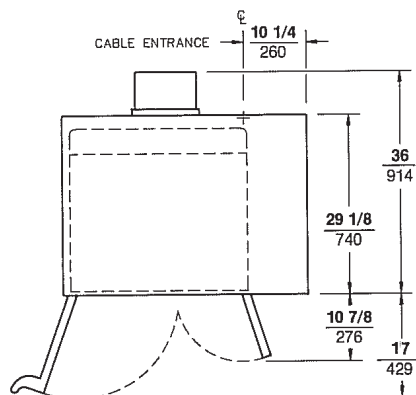

SINGLE OVEN

Note: If unit is on casters, add 5"/127mm to overall height for single deck, deduct 1-1/2"/38mm from overall height for double deck.

INTERIOR DIMENSIONS (per deck)

W	H	D
29/736	20 1/2/520	21 1/2/546

INSTALLATION NOTES

MODEL #	TOTAL KW LOADING	NOMINAL AMPERES PER LINE*									
		208VAC/1PH	240VAC/1PH	208VAC/3PH	X	Y	Z	240VAC/3PH	X	Y	Z
ECO-E-10	11.0 KW	53	46		32	32	28		28	28	24
ECO-E-20	22.0 KW	106	92		60	65	60		52	56	52

*Includes 1/2 HP Fan Motor

Note: 208 VAC=197 to 219 VAC/240 VAC=220 to 252 VAC
 1 Speed Motor, 1725 RPM (60 HZ)
 2 Speed Motor, 1140 and 1725 RPM (60HZ)

Combustible Wall Clearances Sides 6" 152 Back 6" 152 Entry Clearance Crated 44 1/2" 1130 Uncrated 34" 864	460V Information Available Upon Request	Shipping Weight ECO-E-10 675#/304 Kg. ECO-E-20 1350#/608 Kg.
--	--	---

Continuous product improvement is a Garland policy. Therefore, specifications and designs are subject to change without notice.