

# GARLAND®

A WELBILT Company

Item #: \_\_\_\_\_

Model # 686

Product Name: 36" Wide - 680 Series  
Medium Duty - Electric Range



Model # 686

(686 Range Shown with optional 12" Hot Top  
and Convection Oven Base, Model 686-1RC)



## Specifications: General —

Electric medium duty range - 36" W x 31¼" D x 37½" H (includes 6" legs). Front serviceable. Optional convection oven available. Stainless steel door, valve panel and backguard, black powder coat epoxy sides and trim. Recommended for churches, schools, cafes and small restaurants. Specify with open elements or with options of hot top(s) and/or griddle.

## Standard Features

- Stainless Steel Door
- Black Powder Coat Epoxy Sides and Trim
- Porcelainized Steel Oven Interior (Sides, Rear, Deck and Door Liner)
- Six Open Elements, Switch Controlled
- Electric Heavy Duty Thermostat
- 6" Adjustable Legs (Brushed Chrome)
- One Standard Oven
- 7" Stainless Steel Backguard

## Optional Features (Additional Charge)

- 12" Thermostatically Controlled Griddle, Add Suffix - 12th, Std. Right Side, Specify Left
- 24" Thermostatically Controlled Griddle, Add Suffix - 24th, Std. Right Side, Specify Left
- 36" Thermostatically Controlled Griddle, Add Suffix - 36th
- 12" Switch Controlled Hot Top, Add Suffix - 1, Std. Left Side, Specify Right
- Two 12" Switch Controlled Hot Tops, Add Suffix - 2, Std. Left Side, Specify Right
- Additional Oven Rack
- Hi-Shelf w/Black Powder Coat Epoxy Backguard and Stainless Steel Plate Shelf
- Hi-Shelf w/Stainless Steel Backguard and Stainless Steel Plate Shelf
- Range Mount Salamander Broiler
- Continuous Clean Oven Interior, Add Suffix - CC
- Convection Oven Base w/Two Speed Fan, Add Suffix - RC
- Stainless Steel Main Back for Rear Exposure
- 6" Adjustable Legs (Stainless Steel)
- Swivel Casters w/Front Brakes

**NOW STANDARD WITH  
STAINLESS STEEL  
FRONT AND SIDES**

Item #: \_\_\_\_\_

Model # 686

Product Name: 36" Wide - 680 Series  
Medium Duty - Electric Range

# GARLAND®

A WELBILT Company

DIMENSIONS: inches or inches/mm  
mm

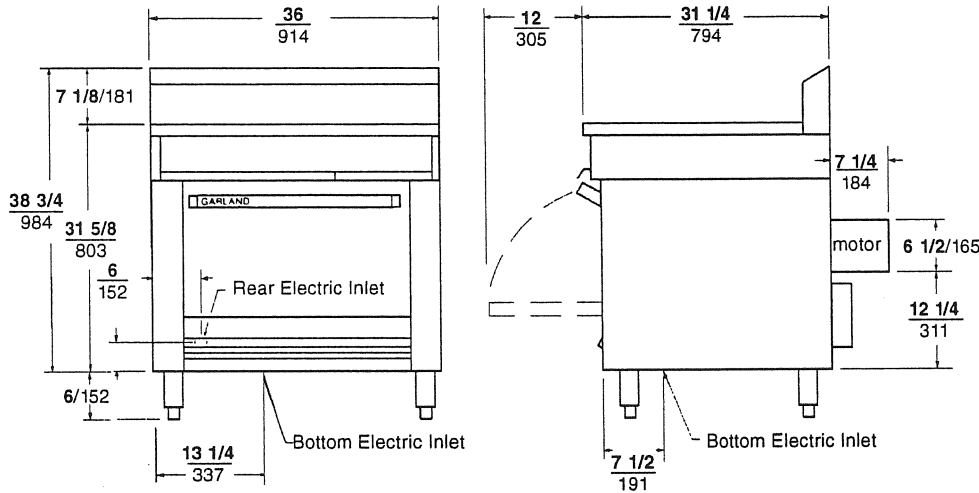

USABLE OVEN DIMENSIONS  
STANDARD OVEN  
22 1/2" x 26 1/4" x 12 1/2"  
317.5 mm x 666.75 mm x 736.6 mm  
RC Oven  
21 1/4" x 26 1/4" x 12 1/2"  
349.25 mm x 666.75 mm x 552.45 mm

**NOTE:**  
For Convection Oven allow additional 7 1/4" to rear of range for installation

**SHIPPING WEIGHT**  
Model 686 445 Lbs.  
Model 686RC 495 Lbs.

Combustible wall clearances:  
Range without Salamander - 3" Sides - 1/2" Back

LOADING CHART

Range with Salamander - 6" Sides - 1/2" Back  
Range with hot top surface element - 6" Sides - 2" Back

BASIC MODEL	COOKING TOP OPTION	OVEN	TOTAL KW	NOMINAL AMPERES PER LINE							
				1 PHASE		3 PHASE					
				208	240	208			240		
					X	Y	Z	X	Y	Z	
686	6 Open Elements or -12th, -24th, -36th	Std.	15.0	72	62	42	43	43	37	38	39
		RC	15.5	75	65	49	44	37	42	38	32
	-1 or -1-12th, -1-24th	Std.	15.8	76	66	45	43	48	39	38	42
		RC	16.2	78	68	51	52	33	44	45	29
	-2	Std.	16.4	79	68	46	43	49	40	37	42
		RC	17.0	82	71	50	55	37	43	48	32
with Salamander Broiler Add		7.0	34	28	34	—	34	29	—	29	

686-3 Available Wiring 240 Volt (220/240) or 208 Volt (197/219) Single or Three Phase. Specify Which is Required.

## TYPICAL EXAMPLES OF TOP COMBINATIONS

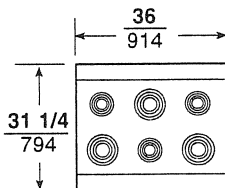

**Model 686**  
6 Open Elements  
1 Oven

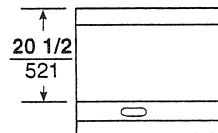

**Model 686-36TH**  
36" (914mm) Griddle  
1 Oven

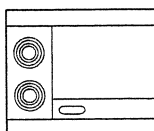

**Model 686-24TH**  
2 Open Elements  
24" (610mm) Griddle  
1 Oven

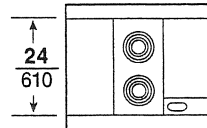

**Model 686-1-12TH**  
1 Hot Top Section  
2 Open Elements  
12" (305mm) Griddle  
1 Oven

Continuous product improvement is a Garland policy.  
Therefore, specifications and designs are subject to change without notice.

Garland Commercial Industries, Inc., 185 East South St., Freeland, PA 18224

Telephone: 717-636-1000 Telefax: 717-636-3903

Printed in U.S.A.